

Página

416 ARANDELA GROWER DIN 7980	IV-06
410 CANCAMO FORJADO DIN 580 (Macho) / DIN 582 (Hembra)	IV-16
409 CANCAMO FUNDICION DIN 580	IV-17
420 CANCAMO GIRATORIO	IV-18
421 CANCAMO "RUD"	IV-19
422 CINTA DE PRECISION EN ESTUCHE	IV-40
423 CINTA DE PRECISION EN ROLLO	IV-41
424 CINTA DE PRECISION EN ROLLO ANCHO VARIABLE	IV-42
499 COLUMNA DE APOYO	IV-44
417 ELEMENTOS FORJADOS DE TRANSPORTE " ET1 "	IV-21
418 ELEMENTOS FORJADOS DE TRANSPORTE " ET2" VDI 3366	IV-22
419 ELEMENTOS FORJADOS DE TRANSPORTE " ET3 "	IV-23
430 ELEMENTOS FORJADOS DE TRANSPORTE " ET4 "	IV-24
431 ELEMENTOS FORJADOS DE TRANSPORTE " ET5 " VDI 3366	IV-25
427 ESLINGAS Y CADENAS "ENORM-Grado 10 EN 818"	IV-20
404 ESPARRAGO ALLEN DIN 913	IV-04
411 LLAVE ALLEN ACODADA DIN 911	IV-05
437 PERNO TRANSPORTE VDI 3366	IV-31
438 PERNO TRANSPORTE VW	IV-32
439 PERNO TRANSPORTE FIAT	IV-33
440 PERNO TRANSPORTE FORD	IV-34
441 PERNO TRANSPORTE OPEL-GM	IV-35
442 PERNO TRANSPORTE PSA-RENAULT	IV-36
443 PERNO TRANSPORTE VOLVO	IV-37
412 POSICIONADOR BOLA / POSICIONADOR PIVOTE ESFERICO	IV-14
444 RECAMBIO PERNO DE TRANSPORTE PARA SOPORTE DE ELEVACION BMW	IV-38
445 RECAMBIO PERNO DE TRANSPORTE PARA SOPORTE DE ELEVACION FIAT	IV-39
432 SOPORTE DE ELEVACION CON TORNILLO DE ELEVACION FIAT "ET6"	IV-26
433 SOPORTE DE ELEVACION CON TORNILLO DE ELEVACION "ET7" RENAULT	IV-27
434 SOPORTE DE ELEVACION CON TORNILLO DE ELEVACION "ET8" BMW	IV-28
435 SOPORTE DE ELEVACION CON TORNILLO DE ELEVACION "ET9" VDI 3366	IV-29
436 SOPORTE DE ELEVACION CON TORNILLO DE ELEVACION "Et10"	IV-30
425 SURTIDO DE CINTA DE PRECISION	IV-43
415 TAPONES DE CIERRE A EXPANSION EXPANDER®	IV-15
407 TOPE GUIA MACHO "TGM"	IV-11
408 TOPE GUIA HEMBRA "TGH"	IV-12
413 TOPE PLACA EXPULSORA "TPE"	IV-13
401 TORNILLO ALLEN DIN 912 - 8.8	IV-02
402 TORNILLO ALLEN DIN 912 - 12.9	IV-01
403 TORNILLO AVELLANADO DIN 7991	IV-03
414 TORNILLO LIMITADOR "KRT"	IV-10
405 TORNILLO LIMITE MACHO "TLM"	IV-08
406 TORNILLO LIMITE HEMBRA "TLH"	IV-09
426 TORNILLO LIMITE "TLE" CON CAÑA RECTIFICADA ISO 7379	IV-07





TORNILLO ALLEN DIN 912 - 12.9

SOCKET HEAD CAP SCREWS DIN 912 - 12.9

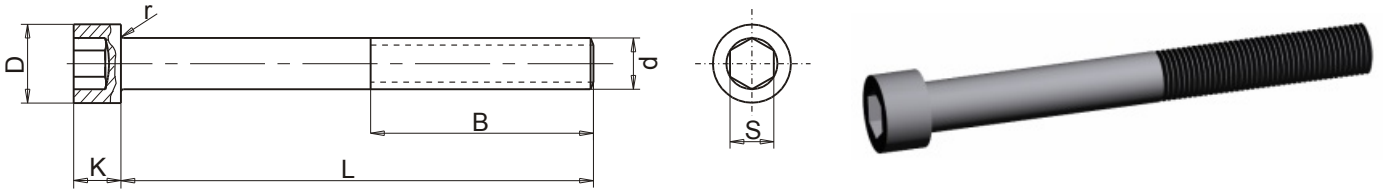

RESISTENCIA A LA TRACCION / TENSILE STRENGTH : (120-140 Kp/mm2)

d	M- 3	M- 4	M- 5	M- 6	M- 8	M- 10	M- 12	M- 14	M- 16	M- 18	M- 20	M- 24	M- 30
b	18	20	22	24	28	32	36	40	44	52	52	60	72
D	5.5	7	8.5	10	13	16	18	21	24	27	30	36	45
K	3	4	5	6	8	10	12	14	16	18	20	24	30
S	2.6	3	4	5	6	8	10	12	14	14	17	19	22
r	0.2	0.2	0.2	0.3	0.5	0.5	1	1	1	1	1	1.6	2

L	M- 3	M- 4	M- 5	M- 6	M- 8	M- 10	M- 12	M- 14	M- 16	M- 18	M- 20	M- 24	M- 30
6	*	*	*										
8	*	*	*	*									
10	*	*	*	*	*								
12	*	*	*	*	*								
14	*	*	*	*	*								
16	*	*	*	*	*	*							
18	*	*	*	*	*	*							
20	*	*	*	*	*	*	*						
22	*	*	*	*	*	*	*						
25	*	*	*	*	*	*	*	*	*				
30	*	*	*	*	*	*	*	*	*	*	*		
35	*	*	*	*	*	*	*	*	*	*	*		
40	*	*	*	*	*	*	*	*	*	*	*	*	
45		*	*	*	*	*	*	*	*	*	*	*	
50		*	*	*	*	*	*	*	*	*	*	*	
55		*	*	*	*	*	*	*	*	*	*	*	
60		*	*	*	*	*	*	*	*	*	*	*	*
65		*	*	*	*	*	*	*	*	*	*	*	*
70		*	*	*	*	*	*	*	*	*	*	*	*
80			*	*	*	*	*	*	*	*	*	*	*
90			*	*	*	*	*	*	*	*	*	*	*
100			*	*	*	*	*	*	*	*	*	*	*
110					*	*	*	*	*	*	*	*	*
120					*	*	*	*	*	*	*	*	*
130					*	*	*	*	*	*	*	*	*
140					*	*	*	*	*	*	*	*	*
150					*	*	*	*	*	*	*	*	*
160					*	*	*	*	*	*	*	*	*
170					*	*	*	*	*	*	*	*	*
180					*	*	*	*	*	*	*	*	*
190						*	*	*	*	*	*	*	*
200						*	*	*	*	*	*	*	*
220						*	*	*	*	*	*	*	*
240						*	*	*	*	*	*	*	*
260						*	*	*	*	*	*	*	*
280						*	*	*	*	*	*	*	*
300						*	*	*	*	*	*	*	*

FORMA DE PEDIDO: d x L ORDER FORM: d x L



TORNILLO ALLEN DIN 912 - 8.8

SOCKET HEAD CAP SCREWS DIN 912 - 8.8

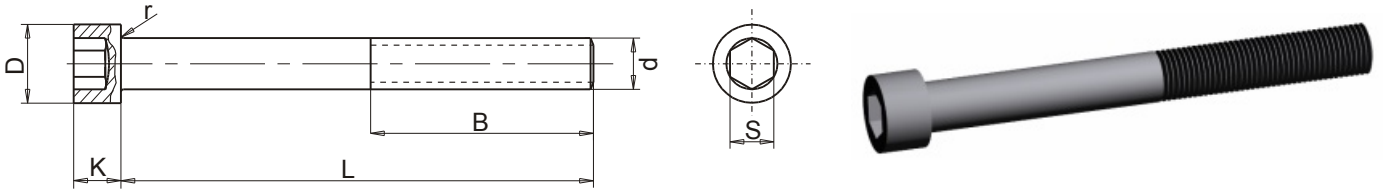

RESISTENCIA A LA TRACCION / TENSILE STRENGTH : (80-100 Kp/mm2)

d	M- 3	M- 4	M- 5	M- 6	M- 8	M- 10	M- 12	M- 14	M- 16	M- 18	M- 20	M- 24	M- 30
b	18	20	22	24	28	32	36	40	44	52	52	60	72
D	5.5	7	8.5	10	13	16	18	21	24	27	30	36	45
K	3	4	5	6	8	10	12	14	16	18	20	24	30
S	2.6	3	4	5	6	8	10	12	14	14	17	19	22
r	0.2	0.2	0.2	0.3	0.5	0.5	1	1	1	1	1	1.6	2

L	M- 3	M- 4	M- 5	M- 6	M- 8	M- 10	M- 12	M- 14	M- 16	M- 18	M- 20	M- 24	M- 30
6	*	*	*										
8	*	*	*	*									
10	*	*	*	*	*								
12	*	*	*	*	*								
14	*	*	*	*	*								
16	*	*	*	*	*	*							
18	*	*	*	*	*	*							
20	*	*	*	*	*	*	*						
22	*	*	*	*	*	*	*						
25	*	*	*	*	*	*	*	*	*				
30	*	*	*	*	*	*	*	*	*	*	*		
35	*	*	*	*	*	*	*	*	*	*	*		
40	*	*	*	*	*	*	*	*	*	*	*	*	
45		*	*	*	*	*	*	*	*	*	*	*	
50		*	*	*	*	*	*	*	*	*	*	*	
55		*	*	*	*	*	*	*	*	*	*	*	
60		*	*	*	*	*	*	*	*	*	*	*	*
65		*	*	*	*	*	*	*	*	*	*	*	*
70		*	*	*	*	*	*	*	*	*	*	*	*
80			*	*	*	*	*	*	*	*	*	*	*
90			*	*	*	*	*	*	*	*	*	*	*
100			*	*	*	*	*	*	*	*	*	*	*
110					*	*	*	*	*	*	*	*	*
120					*	*	*	*	*	*	*	*	*
130					*	*	*	*	*	*	*	*	*
140					*	*	*	*	*	*	*	*	*
150					*	*	*	*	*	*	*	*	*
160					*	*	*	*	*	*	*	*	*
170					*	*	*	*	*	*	*	*	*
180					*	*	*	*	*	*	*	*	*
190						*	*	*	*	*	*	*	*
200						*	*	*	*	*	*	*	*
220						*	*	*	*	*	*	*	*
240						*	*	*	*	*	*	*	*
260						*	*	*	*	*	*	*	*
280						*	*	*	*	*	*	*	*
300						*	*	*	*	*	*	*	*

FORMA DE PEDIDO: d x L ORDER FORM: d x L



TORNILLO AVELLANADO DIN 7991 SOCKET HEAD CAP SCREWS DIN 7991

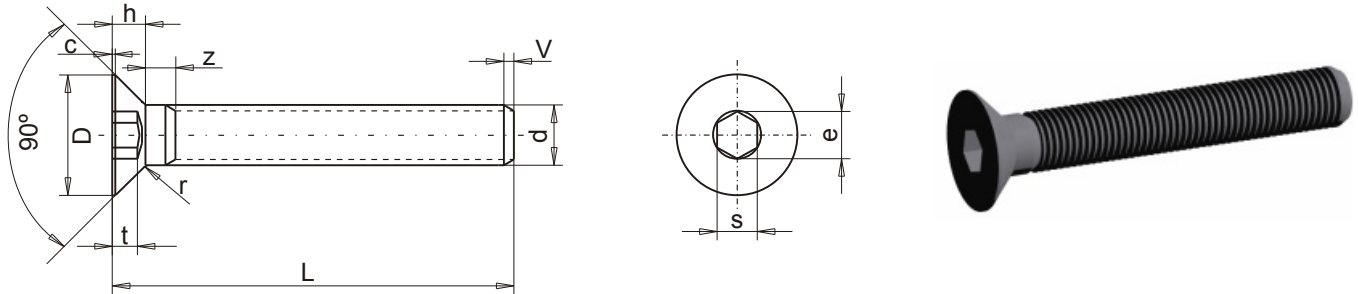

RESISTENCIA A LA TRACCION / TENSILE STRENGTH : (100-120 Kp/mm2)

d	M-3	M-4	M-5	M-6	M-8	M-10	M-12	M-14	M-16	M-20
D	6	8	10	12	16	20	24	27	30	36
h	1.7	2.3	2.8	3.3	4.4	5.5	6.5	7	7.5	8.5
c	0.2	0.3	0.3	0.3	0.4	0.5	0.5	0.5	0.5	0.5
r	0.1	0.2	0.2	0.3	0.5	0.5	1	1	1	1
s	2	2.5	3	4	5	6	8	10	10	12
t	1.3	2	2.4	2.8	3.8	4.8	5	5.3	5.8	6.8
e	2.3	2.9	3.5	4.7	5.8	7	9.4	11.7	11.7	14
v	0.5	0.7	0.8	1	1.25	1.5	1.75	2	2	2.5
z	1	1.4	1.6	2	2.5	3	3.5	4	4.5	5

L	M-3	M-4	M-5	M-6	M-8	M-10	M-12	M-14	M-16	M-20
8	*	*	*							
10	*	*	*	*						
12	*	*	*	*						
16	*	*	*	*	*	*				
18	*	*	*	*	*	*				
20	*	*	*	*	*	*	*			
25	*	*	*	*	*	*	*	*		
30	*	*	*	*	*	*	*	*	*	
35		*	*	*	*	*	*	*	*	*
40		*	*	*	*	*	*	*	*	*
45			*	*	*	*	*	*	*	*
50			*	*	*	*	*	*	*	*
55				*	*	*	*	*	*	*
60				*	*	*	*	*	*	*
70					*	*	*	*	*	*
80					*	*	*	*	*	*
90						*	*	*	*	*
100						*	*	*	*	*

FORMA DE PEDIDO: d x L ORDER FORM: d x L



ESPARRAGO ALLEN DIN 913

SCREW PLUGS DIN 913

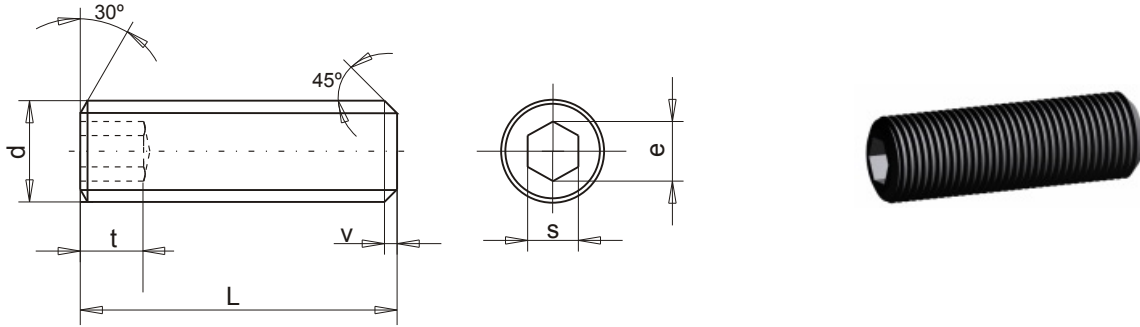

RESISTENCIA A LA TRACCION / TENSILE STRENGTH : (120 Kp/mm2)

d	M-2,5	M-3	M-4	M-5	M-6	M-8	M-10	M-12	M-14	M-16	M-20	M-24
paso	0.45	0.5	0.7	0.8	1	1.25	1.5	1.75	2	2	2.5	3
e	1.5	1.8	2.3	2.9	3.5	4.7	5.8	7	7	9.4	11.7	14
s	1.3	1.5	2	2.5	3	4	5	6	6	8	10	12
t	2	2	2.5	3	3.5	5	6	8	8	10	12	15
v	0.5	0.5	0.75	0.75	1	1.25	1.5	1.75	2	2	2.5	3

L	M-2,5	M-3	M-4	M-5	M-6	M-8	M-10	M-12	M-14	M-16	M-20	M-24
3	*	*	*									
4	*	*	*	*								
5	*	*	*	*	*							
6	*	*	*	*	*	*						
8	*	*	*	*	*	*						
10	*	*	*	*	*	*	*					
12	*	*	*	*	*	*	*	*	*			
16		*	*	*	*	*	*	*	*	*		
20		*	*	*	*	*	*	*	*	*	*	*
25		*	*	*	*	*	*	*	*	*	*	*
30		*	*	*	*	*	*	*	*	*	*	*
35			*	*	*	*	*	*	*	*	*	
40			*	*	*	*	*	*	*	*	*	*
45				*	*	*	*	*	*	*	*	
50				*	*	*	*	*	*	*	*	*
55					*	*	*	*	*	*	*	*
60					*	*	*	*	*	*	*	*
70						*	*	*	*	*	*	*
80						*	*	*	*	*	*	*
90						*	*	*	*	*	*	*
100						*	*	*	*	*	*	*

FORMA DE PEDIDO: d x L ORDER FORM: d x L



LLAVE ALLEN ACODADA DIN 911

SOCKET SCREW ALLEN KEY DIN 911

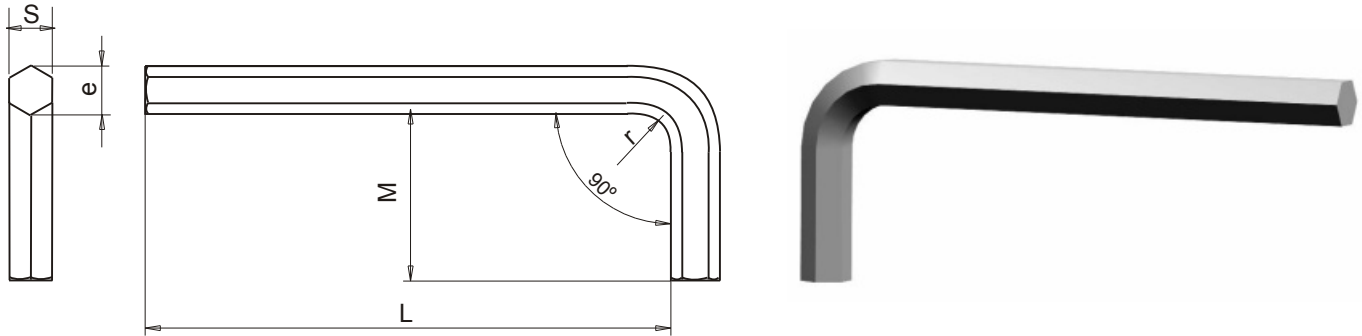

MATERIAL: 50 Cr V4.
DUREZA / HARDNESS : 45-50 HRc.
RESISTENCIA / RESISTANCE : 140 - 165 Kg/mm2.

S	e	L	M	r
1.5	1.73	50	12	2
2	2.3	55	15	2
2.5	2.9	60	18	2.5
3	3.5	65	20	3
4	4.6	72	25	4
5	5.8	80	28	5
6	6.9	90	32	6
8	9.2	100	36	8
10	11.5	112	40	10
12	13.8	125	45	12
14	16.2	140	55	14
17	19.6	160	60	16
18	22	180	70	18

FORMA DE PEDIDO: S ORDER FORM: S



ARANDELA GROWER DIN 7980

GROWER RING DIN 7980

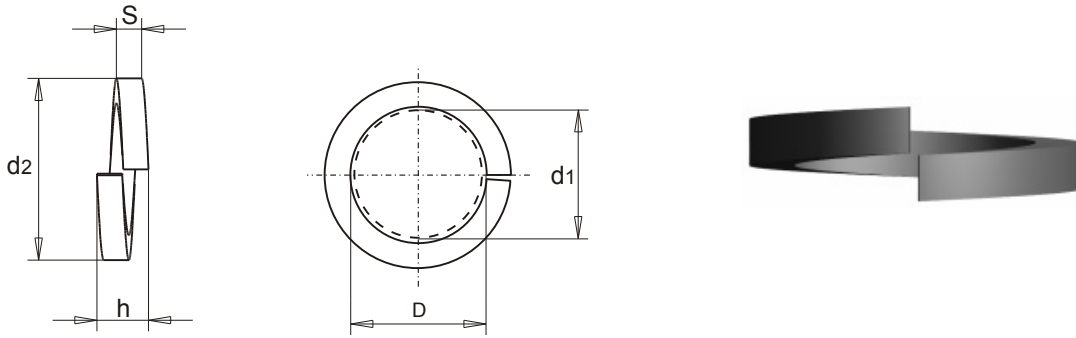

MATERIAL: 100-120 Kp/mm2.

D	h	d1	d2	S
4	2,4-2,83	4.1	7	1.2
5	3,2-3,78	5.1	8.8	1.6
6	3,2-3,78	6.1	9.9	1.6
8	4-4,78	8.1	12.7	2
10	5-5,9	10.2	16	2.5
12	5-5,9	12.2	18	2.5
16	7-8,25	16.2	24.4	2.5

FORMA DE PEDIDO / ORDER FORM : D



TORNILLO LIMITE "TLE" CON CAÑA RECTIFICADA ISO 7379 SHOULDER SCREWS "TLE" WITH GROUND SHAFT ISO 7379

NORMATIVA : ISO 7379
NORMATIVE : ISO 7379
MATERIAL: ISO 12.9
MATERIAL: ISO 12.9
TOLERANCIA DE LA CAÑA : "f9"
TOLERANCE OF SHAFT: "f9"
RESISTENCIA A LA RUPTURA POR TRACCION: 110-120 kg/mm2.
TENSIL STRENGTH: 110-120 kg/mm2.
LIMITE DE ELASTICIDAD: 90 kg/mm min.
LIMIT OF ELASTICITY: 90 kg/mm min.
ELONGAMIENTO: 9% min
STRETCH: 9% min
DUREZA: HRC 38-44
HARDNESS: HRC 38-44

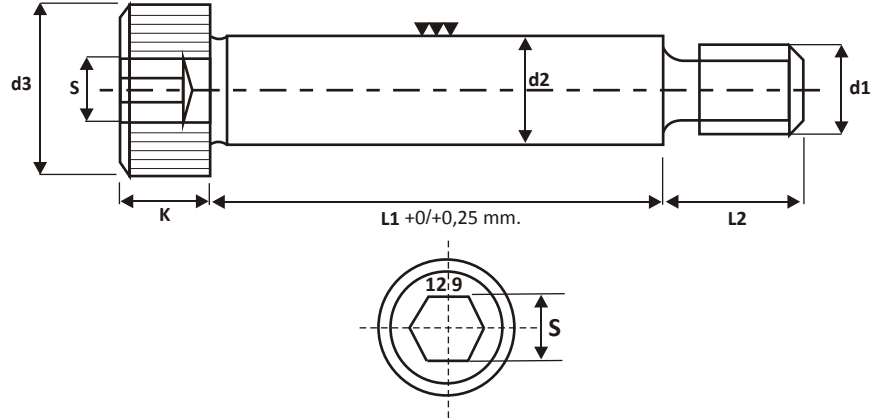

d3	8	10	13	16	18	24	30	36
K	4	4,5	5,5	7	9	11	14	16
L2 Max.	8	9,75	11,25	13,25	16,40	18,40	22,40	27,40
S	2,5	3	4	5	6	8	10	12
d1	M4	M5	M6	M8	M10	M12	M16	M20
d2 - "f9"	5	6	8	10	12	16	20	24
L1								
10	*	*	*	--	--	--	--	--
12	*	*	*	--	--	--	--	--
15	*	*	*	*	*	--	--	--
16	*	*	*	*	*	--	--	--
20	*	*	*	*	*	--	--	--
25	*	*	*	*	*	*	--	--
30	*	*	*	*	*	*	*	--
35	*	*	*	*	*	*	*	--
40	*	*	*	*	*	*	*	*
45	*	*	*	*	*	*	*	*
50	*	*	*	*	*	*	*	*
55	Nueva medida M4 x Ø 5 New dimension M4 x Ø 5	*	*	*	*	*	*	*
60		*	*	*	*	*	*	*
65		*	*	*	*	*	*	*
70		*	*	*	*	*	*	*
80		*	*	*	*	*	*	*
90		--	*	*	*	*	*	*
100		--	*	*	*	*	*	*
110		--	--	*	*	*	*	*
120		--	--	*	*	*	*	*
140		--	--	--	*	*	*	*
160	--	--	--	--	--	*	*	
200	--	--	--	--	--	*	*	

FORMA DE PEDIDO: d1 x d2 x L1
ORDER FORM: d1 x d2 x L1



TORNILLO LIMITE MACHO "TLM" SHOULDER BOLT "TLM"

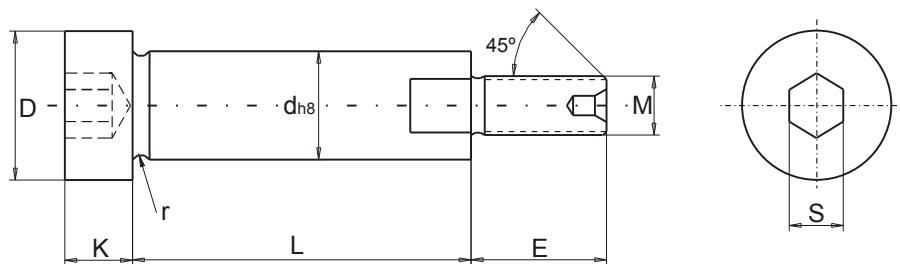

MATERIAL: Acero aleado Cromo-Níquel-Molibdeno.
Special alloyed steel Cr-Ni-Mo.

RESISTENCIA A LA TRACCION: 120 - 140 Kg/mm2.
TENSILE STRENGTH :

M	M- 5	M- 6	M- 8	M-10	M-12	M-16	M-20	M-24
d (h8)	6	8	10	12	16	20	25	32
D (h13)	9	11	14	18	22	28	36	45
K (h14)	4	5	6	8	10	12	16	20
E	8	10	12	16	20	25	32	40
S	3	4	5	6	8	10	14	17
r	0.4	0.5	0.6	0.8	0.9	1	1.2	1.5

M	M- 5	M- 6	M- 8	M-10	M-12	M-16	M-20	M-24
d (h8)	6	8	10	12	16	20	25	32
L								
6	*	*	*					
8	*	*	*	*				
10	*	*	*	*	*			
12	*	*	*	*	*			
14	*	*	*	*	*			
16	*	*	*	*	*	*		
20	*	*	*	*	*	*	*	
25	*	*	*	*	*	*	*	
30	*	*	*	*	*	*	*	
32	*	*	*	*	*	*	*	
40	*	*	*	*	*	*	*	
50	*	*	*	*	*	*	*	*
60	*	*	*	*	*	*	*	*
63	*	*	*	*	*	*	*	*
70		*	*	*	*	*	*	*
80		*	*	*	*	*	*	*
90		*	*	*	*	*	*	*
100		*	*	*	*	*	*	*
110		*	*	*	*	*	*	*
120			*	*	*	*	*	*
125			*	*	*	*	*	*
140			*	*	*	*	*	
160			*	*	*	*	*	*
200				*	*	*	*	*
250					*	*	*	*

FORMA DE PEDIDO: ORDER FORM: M x d x L

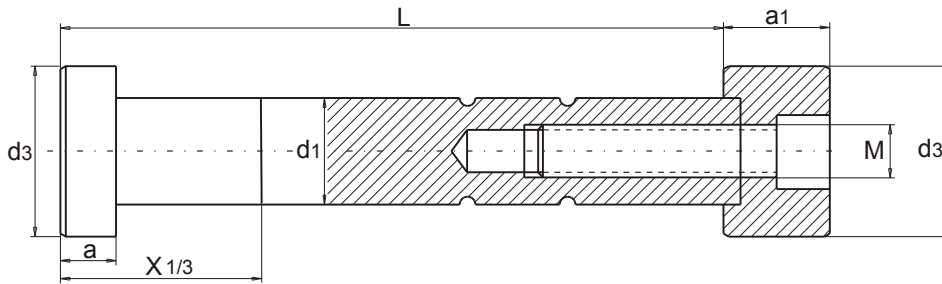

TORNILLO LIMITE HEMBRA "TLH" SHOULDER BOLT "TLH"

**MATERIAL:**

Acero aleado Cromo Molibdeno.
Special alloyed steel Cr-Ni-Mo.

RESISTENCIA A LA TRACCION:**TENSILE STRENGTH :**

110 - 120 Kg/mm².

d1	d3	a	a1	M	L								
					100	120	140	160	180	200	220	240	260
16	26	5	16	8	*	*	*	*	*				
20	32	6	20	10		*	*	*	*	*	*	*	
25	38	7	24	12		*	*	*	*	*	*	*	*

FORMA DE PEDIDO: ORDER FORM: d1 x L



TORNILLO LIMITADOR "KRT" STOPPER BOLT "KRT"

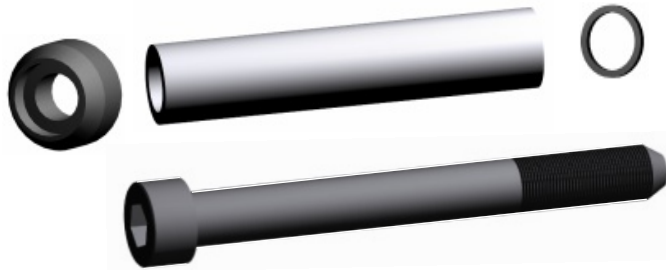
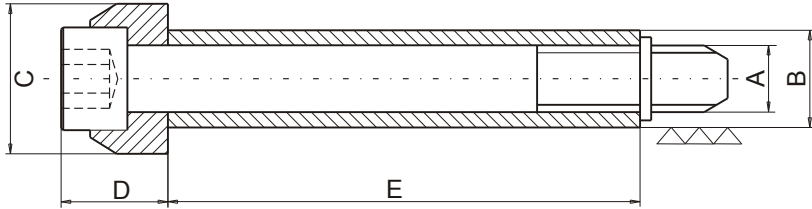

MATERIAL: Acero 1.7242 / Steel 1.7242
DUREZA / HARDNESS: 46-48 HRc

A	B	C	D	E														
				20	25	30	35	40	45	50	55	60	70	80	90	100	110	120
6MA	10	15	10	*	*	*	*	*	*	*	*	*						
8MA	13	19	13			*	*	*	*	*	*	*	*	*				
10MA	16	23	15			*	*	*	*	*	*	*	*	*	*	*		
12MA	18	26	18					*	*	*	*	*	*	*	*	*	*	*
16MA	23	34	24							*	*	*	*	*	*	*	*	*

FORMA DE PEDIDO: A x E
ORDER FORM: A x E



TOPE GUIA MACHO "TGM" GUIDE STOP "TGM"

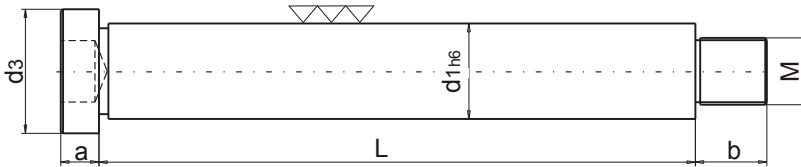

MATERIAL: Acero 1.7242 / Steel 1.7242
DUREZA / HARDNESS: 46-48 HRc.

d1 h6	d3	a	b	M	L								
					40	50	60	80	100	125	150	175	200
14	20	8	12	10	*	*	*	*	*	*	*		
20	26	8	15	14			*	*	*	*	*	*	*

FORMA DE PEDIDO: ORDER FORM: d1 x L



TOPE GUIA HEMBRA "TGH" GUIDE STOP "TGH"

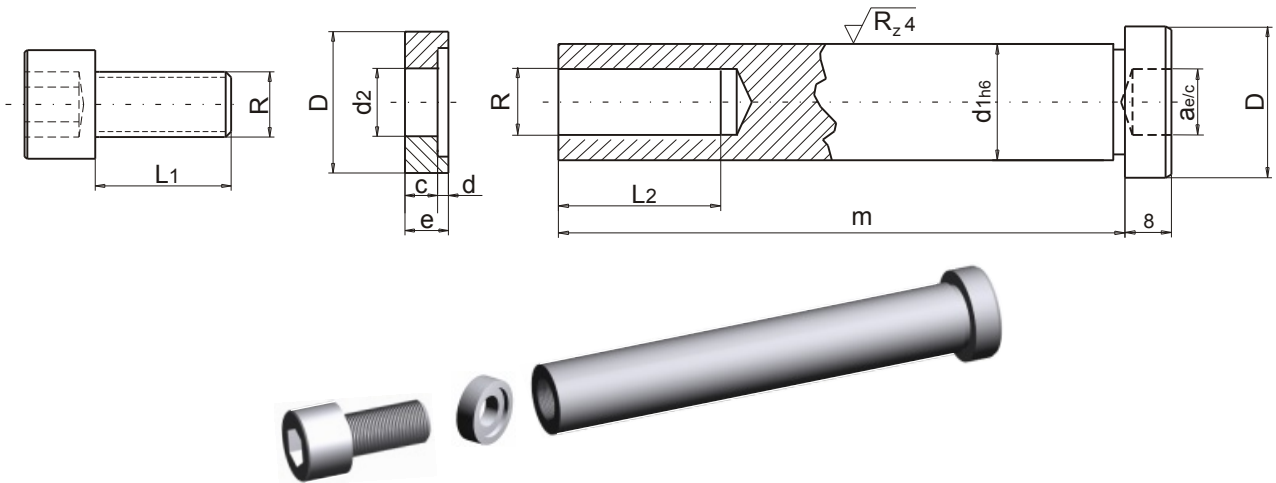

MATERIAL: Acero 1.1730 / Steel 1.1730
DUREZA / HARDNESS: 50-52 HRC.

d1 h6	D	d2	a	c	d	e	L1	L2	R	m								
										40	50	60	80	100	125	150	175	200
14	20	8.5	8	4	2	6	20	18	M-8	*	*	*	*	*	*	*		
20	26	12.5	10	6	2	8	25	25	M-12			*	*	*	*	*	*	*

FORMA DE PEDIDO: ORDER FORM: d1 x m



TOPE PLACA EXPULSORA "TPE" STOP FOR EJECTION PLATE "TPE"

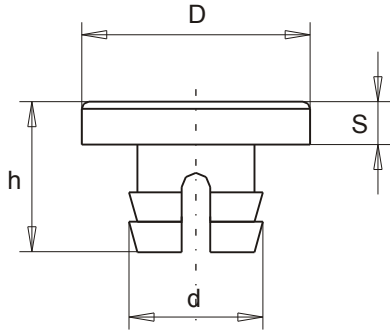

MATERIAL: Acero 1.7242 / Steel 1.7242

D	d	h	S
16	8.2	11	3
25	8.2	11	3

FORMA DE PEDIDO: ORDER FORM: D

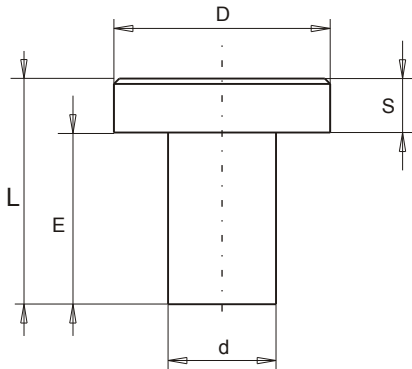
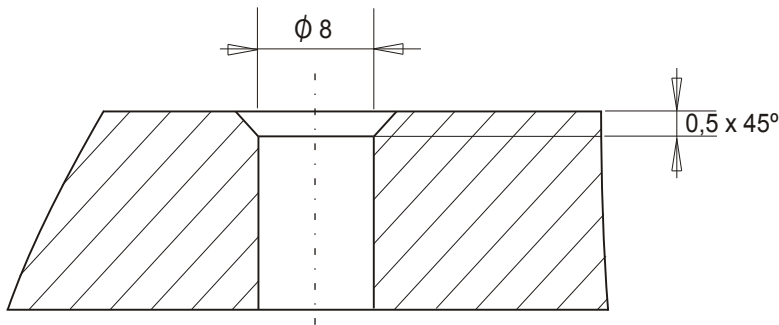

MATERIAL: Acero 1.7242 / Steel 1.7242

d	D	S	E	L
8	15	4	16	20
10	20	5	10	15

FORMA DE PEDIDO: ORDER FORM: d

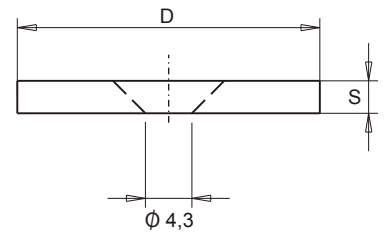

MATERIAL: Acero 1.7242 / Steel 1.7242

D	S
18	3
28	3

FORMA DE PEDIDO: ORDER FORM: D



POSICIONADOR BOLA / POSICIONADOR PIVOTE ESFERICO BALL PLUNGER / SFERIC PIVOT PLUNGER

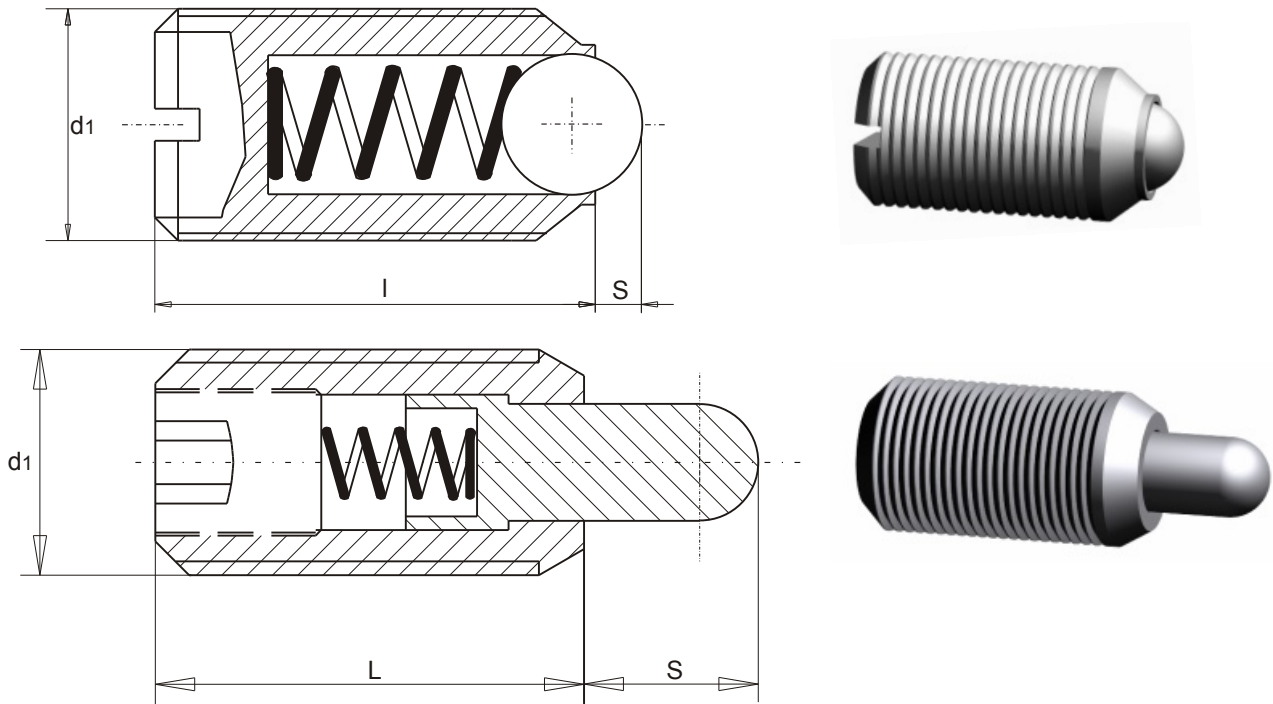

MATERIAL: Acero F-114. Pavonado.

MATERIAL: Steel F-114

d1	l	s	Diam.Bola Ball Diam.
M-3	7	0.5	1.5
M-4	9	0.8	2.5
M-5	12	0.9	3
M-6	14	1	3.5
M-8	16	1.5	5
M-10	19	2	6
M-12	22	2.5	8
M-16	24	3.5	10
M-20	30	4.5	12
M-24	34	5.5	15

FORMA DE PEDIDO : d1/bola.

ORDER FORM : d1/ball

MATERIAL: Acero F-114. Pavonado.

MATERIAL: Steel F-114

d1	l	s	Diam. Pivote Sferic pivot Diam.
M-4	9	1.5	1.8
M-5	12	2	2.4
M-6	14	2	2.7
M-8	16	2	4
M-10	19	2.5	4.5
M-12	22	3.5	6
M-16	24	4.5	8.5
M-20	30	6.5	10
M-24	34	8	12

FORMA DE PEDIDO : d1/pivote.

FORMA DE PEDIDO : d1/Sferic pivot



TAPONES DE CIERRE A EXPANSION EXPANDER[®] EXPANDER[®] SEALING PLUGS

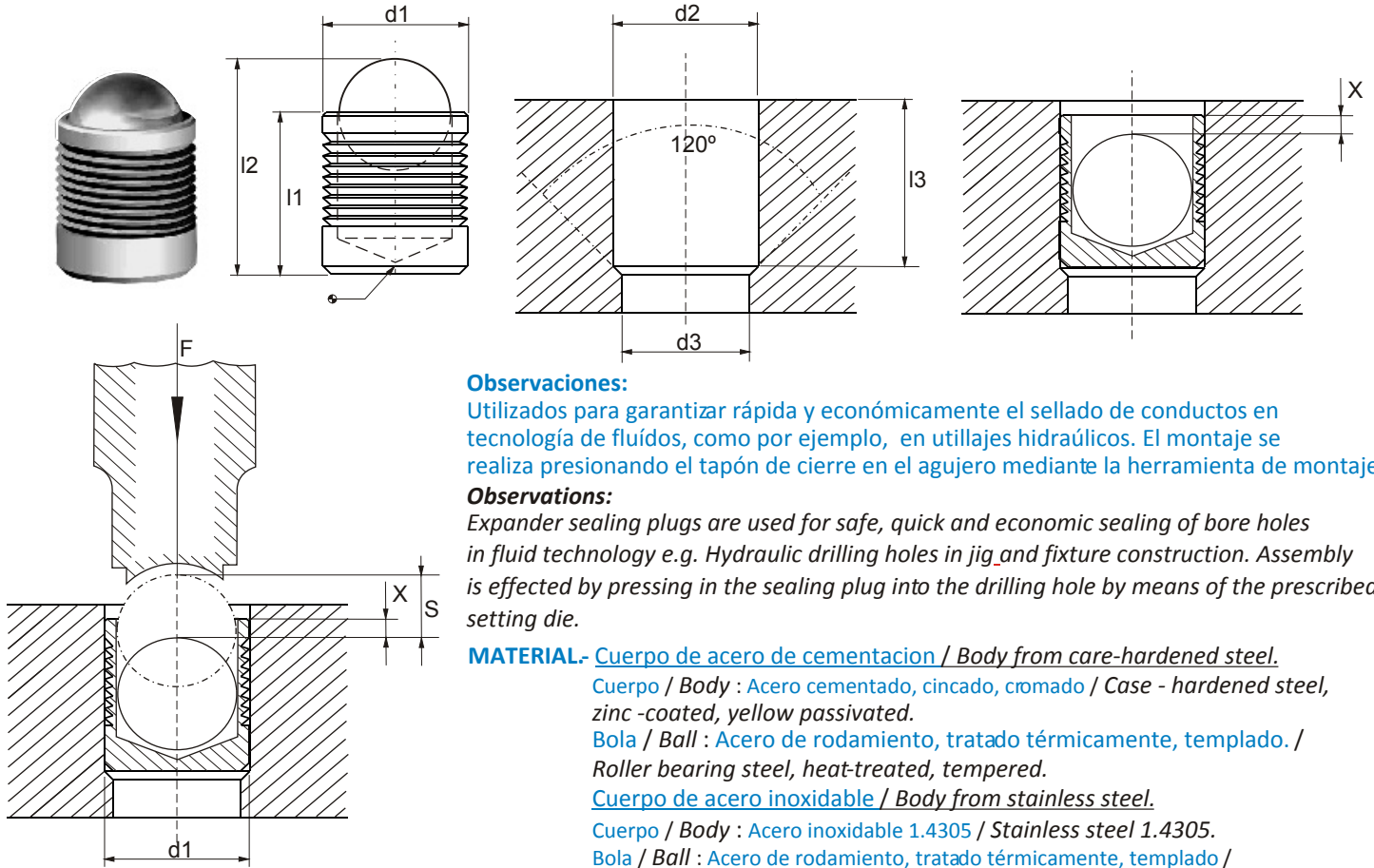

Observaciones:

Utilizados para garantizar rápida y económicamente el sellado de conductos en tecnología de fluidos, como por ejemplo, en utillajes hidráulicos. El montaje se realiza presionando el tapón de cierre en el agujero mediante la herramienta de montaje.

Observations:

Expander sealing plugs are used for safe, quick and economic sealing of bore holes in fluid technology e.g. Hydraulic drilling holes in jig and fixture construction. Assembly is effected by pressing in the sealing plug into the drilling hole by means of the prescribed setting die.

MATERIAL- Cuerpo de acero de cementacion / Body from case-hardened steel.

Cuerpo / Body : Acero cementado, cincado, cromado / Case - hardened steel, zinc -coated, yellow passivated.

Bola / Ball : Acero de rodamiento, tratado térmicamente, templado. / Roller bearing steel, heat-treated, tempered.

Cuerpo de acero inoxidable / Body from stainless steel.

Cuerpo / Body : Acero inoxidable 1.4305 / Stainless steel 1.4305.

Bola / Ball : Acero de rodamiento, tratado térmicamente, templado. / Roller bearing steel, heat-treated, tempered.

d1	l1	l2	d2 +0,1	d3 max.	l3 Min.	x ±0,2	s	Peso gr. Weight gr.
3	3,6	4,6	3	2,2	3,4	0,4	1,2	0,2
4	4	5,2	4	3,3	3,8	0,2	1,5	0,4
5	5,5	7	5	4,3	5,3	0,4	2	0,7
6	6,5	8,6	6	5,3	6,3	0,4	2,5	1,2
7	7,5	10,1	7	6,4	7,3	0,4	3	1,9
8	8,5	11,7	8	7,4	8,3	0,3	3,5	3,1
9	10	13,7	9	8,4	9,8	0,4	4	4,1
10	11	15,2	10	9,4	10,8	0,4	4,5	6
12	13	18	12	10,6	12,8	0,4	5,5	9,4
14	15	20,8	14	12,7	14,5	0,4	6,35	14,4
16	17	23,7	16	14,7	16,5	0,6	7	21,7
18	19	26,3	18	16,7	18,5	0,6	8	32,4
20	22	30,5	20	18,7	21,5	0,8	9	44,7
22	25	34,2	22	20,7	24,5	0,8	10	59,3

FORMA DE PEDIDO / ORDER FORM : Material x d1



CANCAMO FORJADO DIN 580 (Macho) / DIN 582 (Hembra) EYE BOLT DIN 580 (Male) DIN 582 (Female)

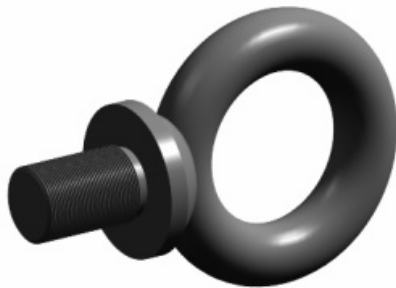
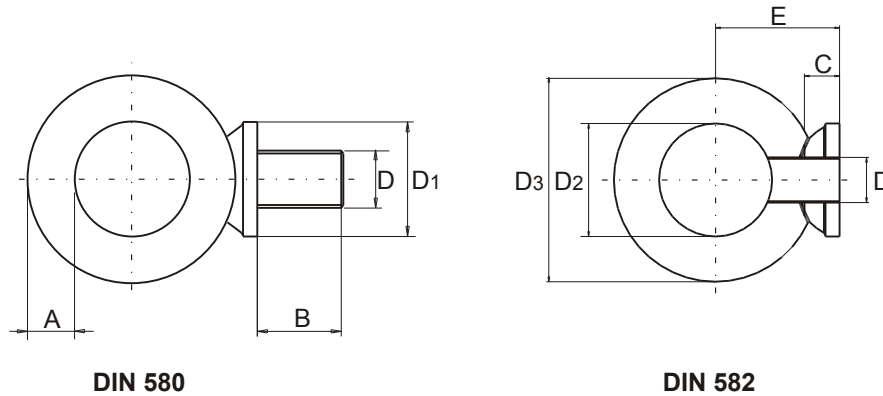

MATERIAL : Acero de forja. / Forged Steel.

D	D1	D2	D3	A	B	C	E	Carga Max en Kgs. Maximum load Kgs.	DIN580	DIN582
M- 8	20	20	36	8	15	8.5	18	140	*	*
M-10	25	25	45	10	18	10	22	230	*	*
M-12	30	30	54	12	22	11	28	340	*	*
M-14	30	30	54	12	22	11	28	340	*	*
M-16	35	35	63	14	28	13	30	700	*	*
M-18	35	35	63	14	28	13	30	900	*	*
M-20	40	40	72	16	30	16	35	1200	*	*
M-22	40	40	72	16	30	16	35	1500	*	*
M-24	50	50	90	20	38	20	45	1800	*	*
M-27	50	50	90	20	38	20	45	2200	*	*
M-30	65	60	108	24	45	25	55	3600	*	*
M-36	75	70	126	28	56	30	65	5100	*	*
M-42	85	80	144	32	65	35	75	7000	*	*
M-48	100	90	166	38	70	40	85	8600	*	*
M-56	110	100	184	42	78	45	95	11500	*	

FORMA DE PEDIDO / ORDER FORM : D - DIN580 o or DIN582



CANCAMO FUNDICION DIN 580

EYE BOLT DIN 580

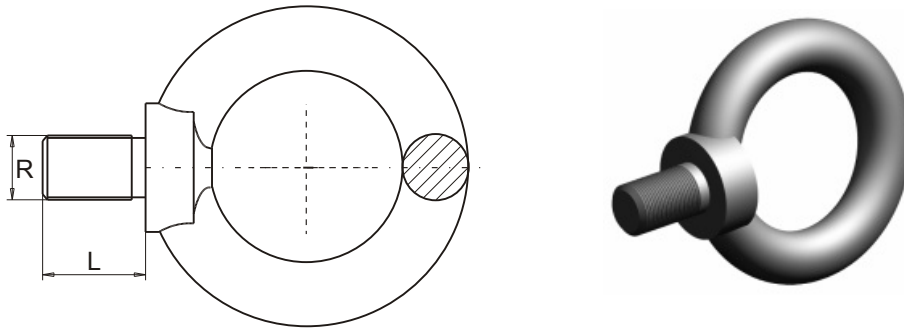

MATERIAL : Acero de fundición. / *Cast ironed steel.*

R	M- 8	M-10	M-12	M-14	M-16	M-18	M-20	M-22	M-24	M-30	M-36	M-42	M-48
Carga max. en Kgs. <i>Maximum load Kgs.</i>	85	150	220	220	380	450	570	800	1050	1700	2500	3400	5200
L	15	18	22	22	26	30	30	32	38	45	55	65	70

FORMA DE PEDIDO / ORDER FORM : R



CANCAMO GIRATORIO REVOLVING EYE BOLT

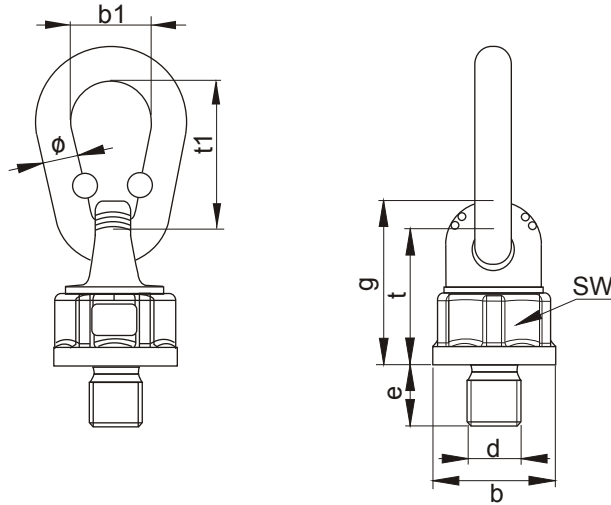

Toneladas Tones	Rosca Thread Version d x e (mm)	Par de apriete Tightening torque (Nm)	Pendiente Pitch DIN 13	øb	g	SW	t	Ring Link ø x t1 x b1 (mm)	Peso Weight (≈ Kg)
TP 0,7	M10x 18	10 - 40	1,5	36,5	48	34	41	13x 55x32	0,42
	M12x 18	15 - 40	1,75	36,5	48	34	41	13x 55x32	0,43
	M12x 25	15 - 40	1,75	36,5	48	34	41	13x 55x32	0,43
	M14x 20	30 - 40	2	36,5	48	34	41	13x 55x32	0,43
TP 1,4	M16x 20	45 - 130	2	36,5	48	34	41	13x 55x32	0,43
	M16x 30	45 - 130	2	36,5	48	34	41	13x 55x32	0,44
	M20x 30	75 - 130	2,5	36,5	48	34	41	13x 55x32	0,46
	M24x 30	90 - 130	3	36,5	48	34	41	13x 55x32	0,49
TP 2,5	M20x 30	100 - 170	2,5	52	68	46	57	16x 70x34	0,95
	M20x 40	100 - 170	2,5	52	68	46	57	16x 70x34	0,97
	M20x 50	100 - 170	2,5	52	68	46	57	16x 70x34	1,04
	M20x 70	100 - 170	2,5	52	68	46	57	16x 70x34	1,07
TP 4	M24x 30	190 - 280	3	57	75	50	63	18x 85x45	1,43
	M24x 45	190 - 280	3	57	75	50	63	18x 85x45	1,48
	M24x 50	190 - 280	3	57	75	50	63	18x 85x45	1,5
	M30x 35	190 - 280	3,5	57	75	50	63	18x 85x45	1,5
TP 6,7	M30x 35	230 - 400	3,5	70	95	65	78	20x 85x45	2,33
	M30x 45	230 - 400	3,5	70	95	65	78	20x 85x45	2,37
	M30x 50	230 - 400	3,5	70	95	65	78	20x 85x45	2,44
	M30x 60	230 - 400	3,5	70	95	65	78	20x 85x45	2,45
TP 8	M30x 35	270 - 600	3,5	81	106	75	86	23x 115x60	3,59
	M30x 45	270 - 600	3,5	81	106	75	86	23x 115x60	3,64
TP 10	M36x 50	270 - 600	4	81	106	75	86	23x 115x60	3,72
	M36x 54	270 - 600	4	81	106	75	86	23x 115x60	3,82
TP 12,5	M42x 50	270 - 700	4,5	81	106	75	86	23x 115x60	3,82
	M42x 60	270 - 700	4,5	81	106	75	86	23x 115x60	3,91
	M42x 63	270 - 700	4,5	81	106	75	86	23x 115x60	3,94
	M45x 60	270 - 700	4,5	81	106	75	86	23x 115x60	4,03
	M48x 72	270 - 700	5	81	106	75	86	23x 115x60	4,33
TP 17	M42x 60	350 - 800	4,5	104	127	95	106	30x 140x70	7,34
	M45x 60	350 - 800	4,5	104	127	95	106	30x 140x70	7,50
	M48x 60	350 - 800	5	104	127	95	106	30x 140x70	7,57
	M56x 78	350 - 900	5,5	104	127	95	106	30x 140x70	8,00
TP 20	M64x 96	350 - 900	6	104	127	95	106	30x 140x70	8,85
	M64x 110	350 - 900	6	104	127	95	106	30x 140x70	9,20
TP 28	M64x 96	500 - 1000	6	129	174	115	135	35x170x80	16,3
	M72x 120	500 - 1200	6	129	174	115	135	35x170x80	17,6
	M80x 150	500 - 1200	6	129	174	115	135	35x170x80	19,5

FORMA DE PEDIDO: d x e x Toneladas
ORDER FORM: d x e x Tones



CANCAMO "RUD" "RUD" EYE BOLT

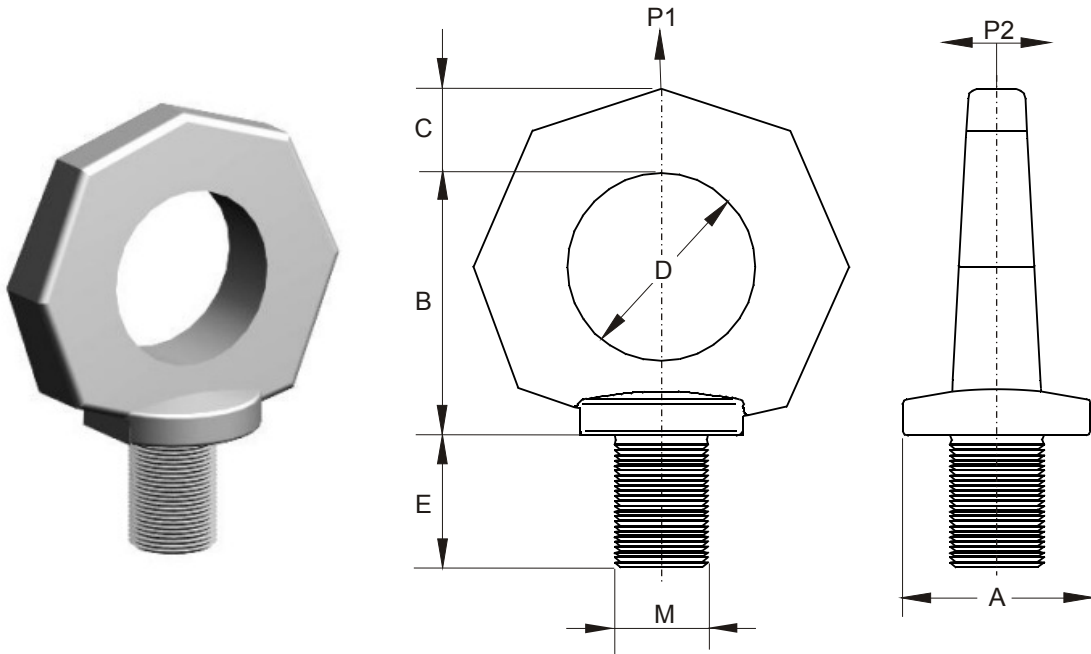

MATERIAL : Acero 1.6541 forjado. / 1.6541 Forged Steel.

M	P1 (Kg.)	P2 (Kg.)	B	C	E	D	A	Peso Weight
M.6	400	100	35	10	12	25	25	0,1
M.8	800	200						
M.10	1.000	250			15			
M.12	1.600	400	41	12	18	30	30	0,2
M.14	3.000	750	48	14	21	35	35	0,25
M.16	4.000	1.000	48	16	24			0,3
M.20	6.000	1.500	55	20	30	40	40	0,45
M.24	8.000	2.000	70		36	50	50	0,7
M.30	12.000	3.000	85	24	45	60	60	1,6
M.36	16.000	4.000	130	43	54	90	100	6,0
M.42	24.000	6.000	130	43	63	90	100	6,2
M.48	32.000	8.000			68			6,4

FORMA DE PEDIDO / ORDER FORM : M



ESLINGAS Y CADENAS “ENORM-Grado 10 EN 818”

CHAIN SLINGS “ENORM-Grade 10 EN 818”

Cadena eslinga con enlace terminal *Chain sling with terminal link*

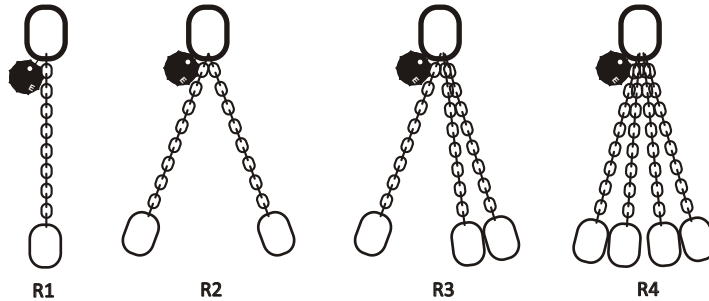

Cadena eslinga con gancho *Chain sling with hook*

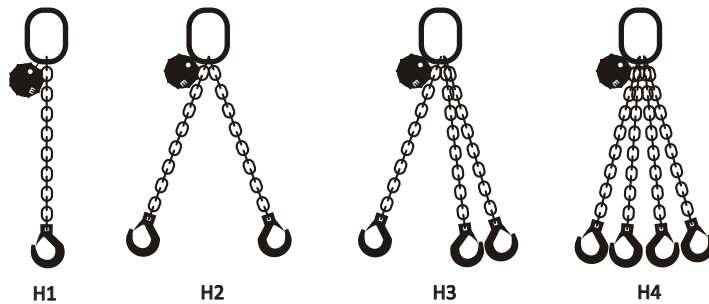

Cadena eslinga con gancho para acortar *Chain sling with hook and shortening clutch*

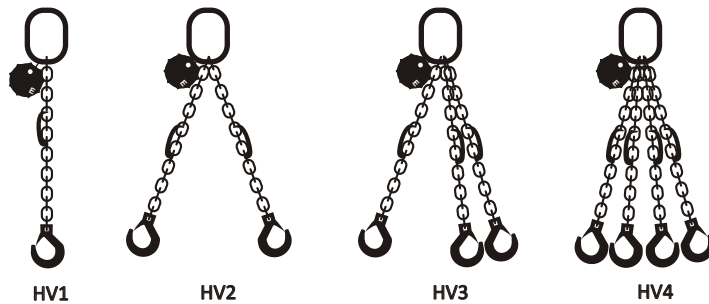

Cadena eslinga sin final. *Endless chain sling.*

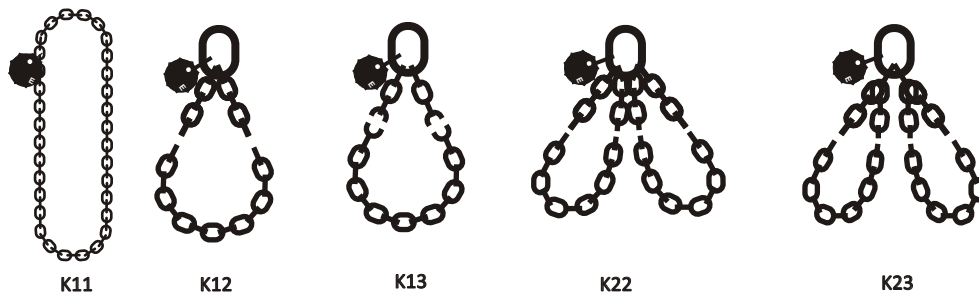

DISPONEMOS DE UN CATALOGO ESPECIFICO DE ESTOS PRODUCTOS. SOLICITELO.
WE HAVE AVAILABLE A COMPLETE CATALOGUE ABOUT THOSE ITEMS. ASK FOR IT.



ELEMENTOS FORJADOS DE TRANSPORTE “ ET1 “ LIFTING STUD “ ET1 “

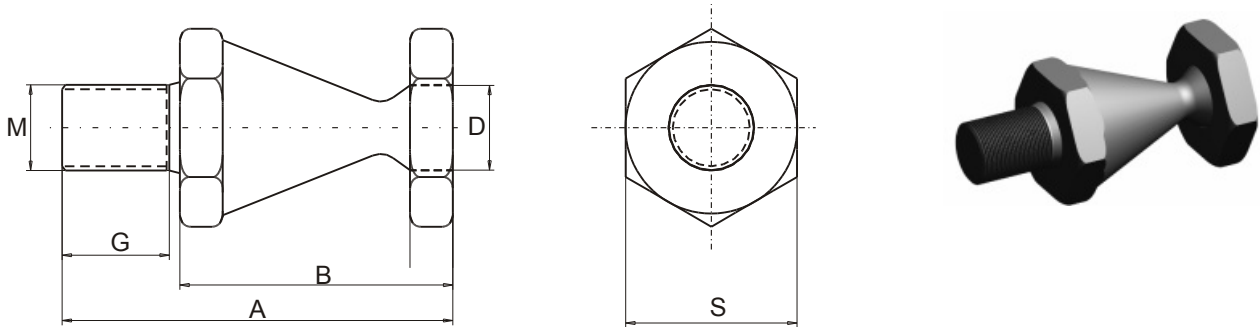

MATERIAL: F1140 pavonado. / F1140

M	S	D	A	B	G	Kg.
16	37	16	76	51	20	100
20	47	20	90	60	25	150

FORMA DE PEDIDO / ORDER FORM : Et1 / M.



ELEMENTOS FORJADOS DE TRANSPORTE " ET2 " VDI 3366

LIFTING BRACKET " ET2 " VDI 3366

"FORMA "A"
"FORM "A"

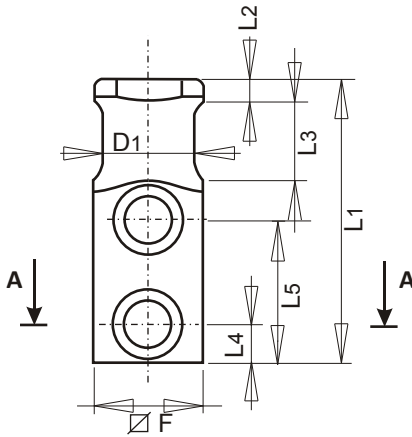

FORMA "B"
FORM "B"

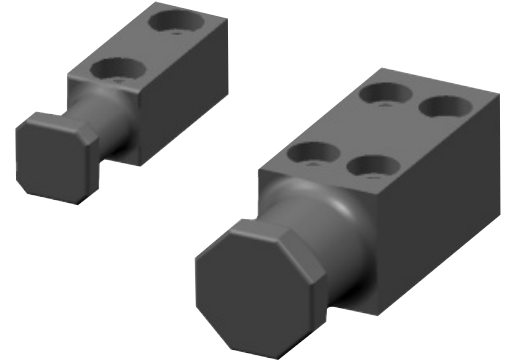
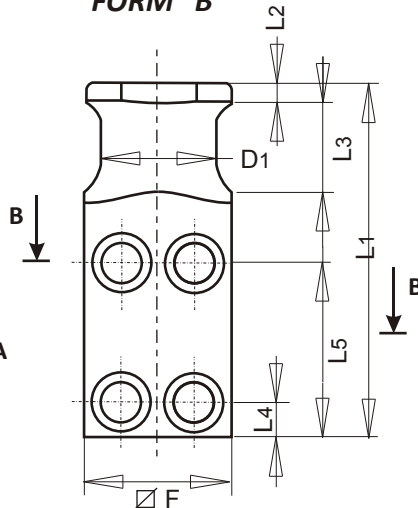

ATENCION: Por razones de seguridad consideren siempre que el peso del troquel o matriz, debe ser soportado por dos elementos.

WARNING: For safety reason, please consider always that the weight of the die has to be supported by just 2 lifting brackets.

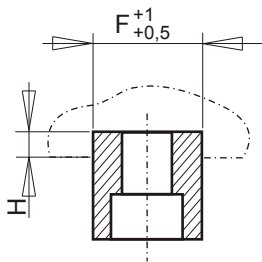

SECCION A-A
SECTION A-A

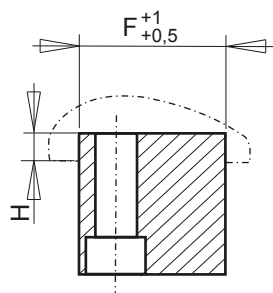

SECCION B-B
SECTION B-B

MATERIAL: CK45
N/mm²: 700:800
Tornillos no incluidos.
Screws not included.

Carga max. Kg. Max. Load Kg.	Peso max. Matriz-troquel Max. Die Weight Kg.	D1	L1	L2	L3	L4	L5	F	H	Forma Form	Tornillo DIN 912-8.8 Screw DIN 912-8.8
320	640	16	80	6	20	10	44	20	6	A	M8x25
630	1260	20	90	8	25	10	47	25	8	A	M10x30
1250	2500	25	100	8	30	12	50	35	10	A	M12x40
2000	4000	32	120	10	32	16	62	40	10	A	M16x45
3200	6400	40	140	10	40	18	72	50	12	A	M20x60
5000	10000	50	160	12	45	22	81	60	14	A	M24x70
8000	16000	63	200	12	50	20	98	80	16	B	M20x90
12500	25000	80	250	15	65	25	125	100	18	B	M24x110
20000	40000	100	300	15	80	30	155	120	20	B	M30x130

FORMA DE PEDIDO / ORDER FORM : ET2 x D1



ELEMENTOS FORJADOS DE TRANSPORTE “ ET3 ” LIFTING BRACKET “ ET3 ”

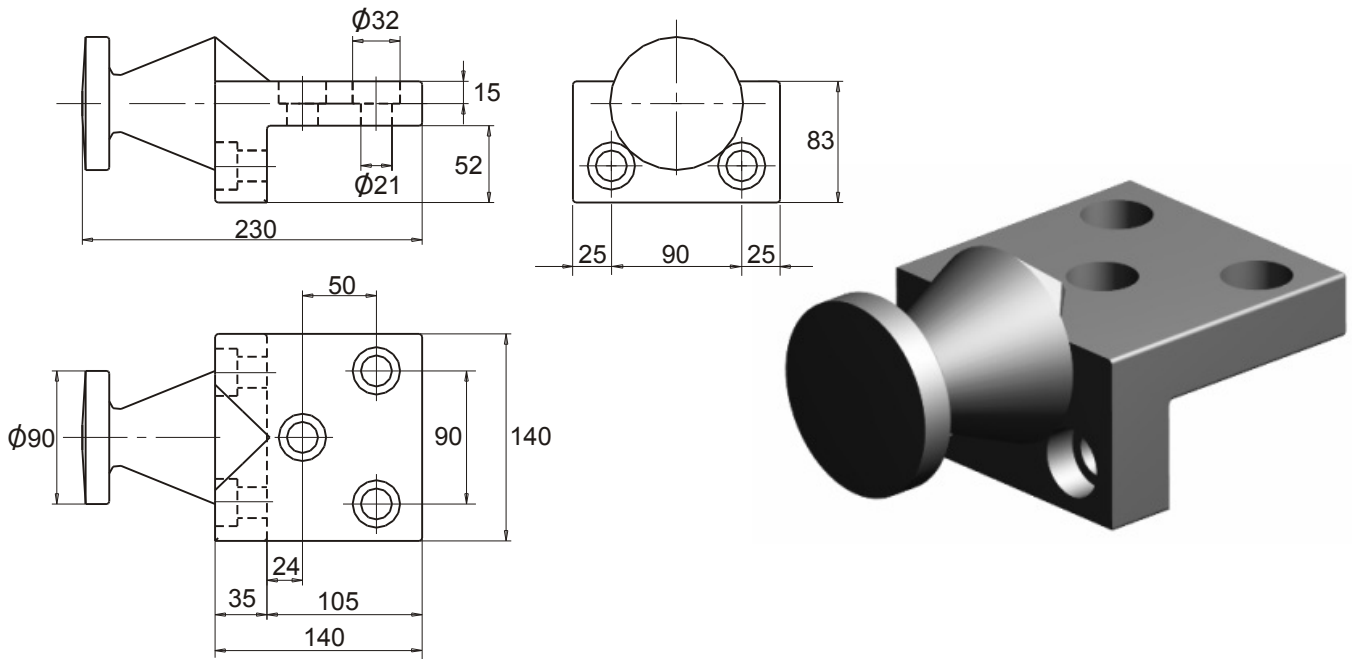

MATERIAL : Acero forjado pavonado. / Forged steel.

FORMA DE PEDIDO / ORDER FORM : ET3



ELEMENTOS FORJADOS DE TRANSPORTE “ ET4 “ LIFTING BRACKET WITH ROPE STOP SAFETY“ ET4 “

“FORMA “A”
“FORM “A”

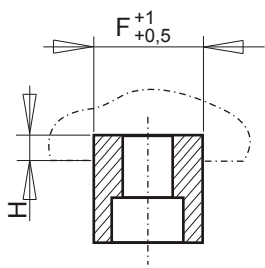
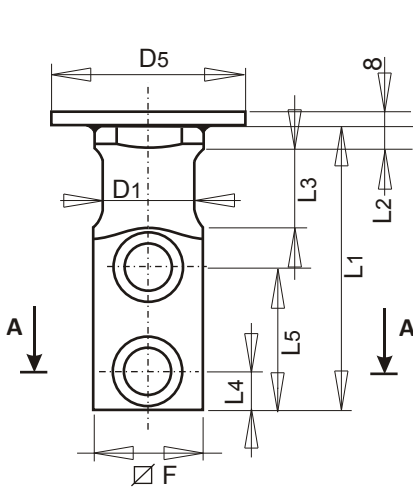

SECCION A-A
SECTION A-A

FORMA “B”
FORM “B”

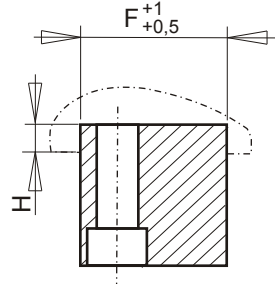
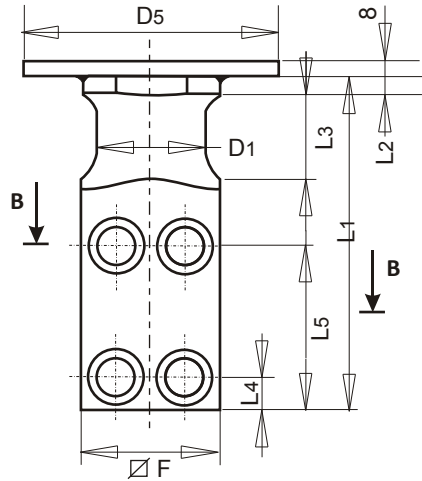

SECCION B-B
SECTION B-B

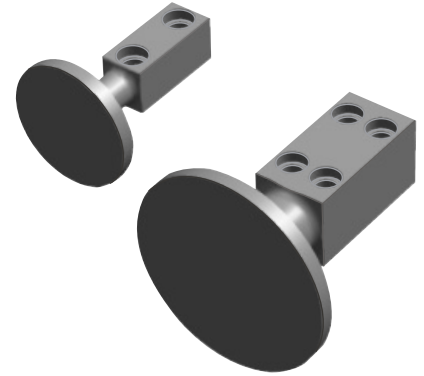

ATENCIÓN: Por razones de seguridad consideren siempre que el peso del troquel o matriz, debe ser soportado por dos elementos.

WARNING: For safety reason, please consider always that the weight of the die has to be supported by just 2 lifting brackets.

MATERIAL: CK45
N/mm²: 700:800
Tornillos no incluidos.
Screws not included.

Carga max. Kg. Max. Load Kg.	Peso max. Matriz-troquel Max. Die Weight Kg.	D1	D2	L1	L2	L3	L4	L5	F	H	Forma Form	Tornillo DIN 912-8.8 Screw DIN 912-8.8
320	640	16	60	80	6	20	10	44	20	6	A	M8x25
630	1260	20	70	90	8	25	10	47	25	8	A	M10x30
1250	2500	25	70	100	8	30	12	50	35	10	A	M12x40
2000	4000	32	110	120	10	32	16	62	40	10	A	M16x45
3200	6400	40	110	140	10	40	18	72	50	12	A	M20x60
5000	10000	50	150	160	12	45	22	81	60	14	A	M24x70
8000	16000	63	150	200	12	50	20	98	80	16	B	M20x90
12500	25000	80	150	250	15	65	25	125	100	18	B	M24x110
20000	40000	100	150	300	15	80	30	155	120	20	B	M30x130

FORMA DE PEDIDO / ORDER FORM : ET4 x D1



ELEMENTOS FORJADOS DE TRANSPORTE “ ET5 “ VDI 3366

LIFTING PIN “ ET5 “ VDI 3366

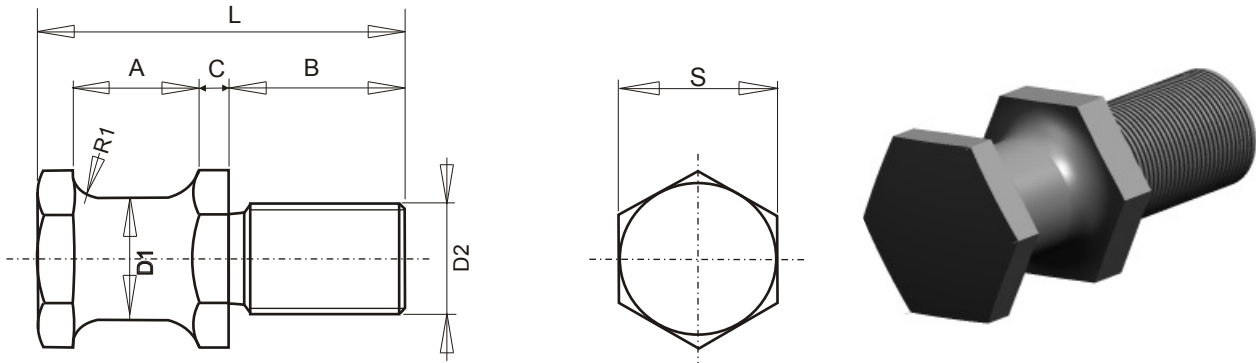

MATERIAL: CK45
N/mm²: 700:800

CE

ATENCION: Por razones de seguridad consideren siempre que el peso del troquel o matriz, debe ser soportado por dos elementos.

WARNING: For safety reason, please consider always that the weight of the die has to be supported by just 2 lifting brackets.

Carga max. Kg. Max. Load Kg.	Peso max. Matriz-troquel Max. Die Weight Kg.	D1	D2	A	B	C	L	S
320	640	16	M16	20	28	5,5	58	24
500	1000	20	M20	22	34	6,5	68	30
1000	2000	25	M24	25	38	8	78	36
1500	3000	32	M30	32	45	10	95	41
2500	5000	40	M36	40	56	12	118	50

FORMA DE PEDIDO / ORDER FORM : ET5 x D1

SOPORTE DE ELEVACION CON TORNILLO DE ELEVACION FIAT "ET6"

FIAT LIFTING BRACKET WITH LIFTING BOLT "ET6"

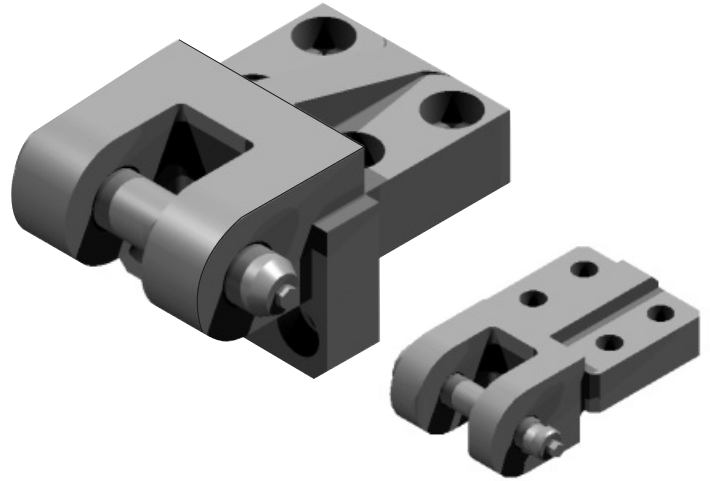
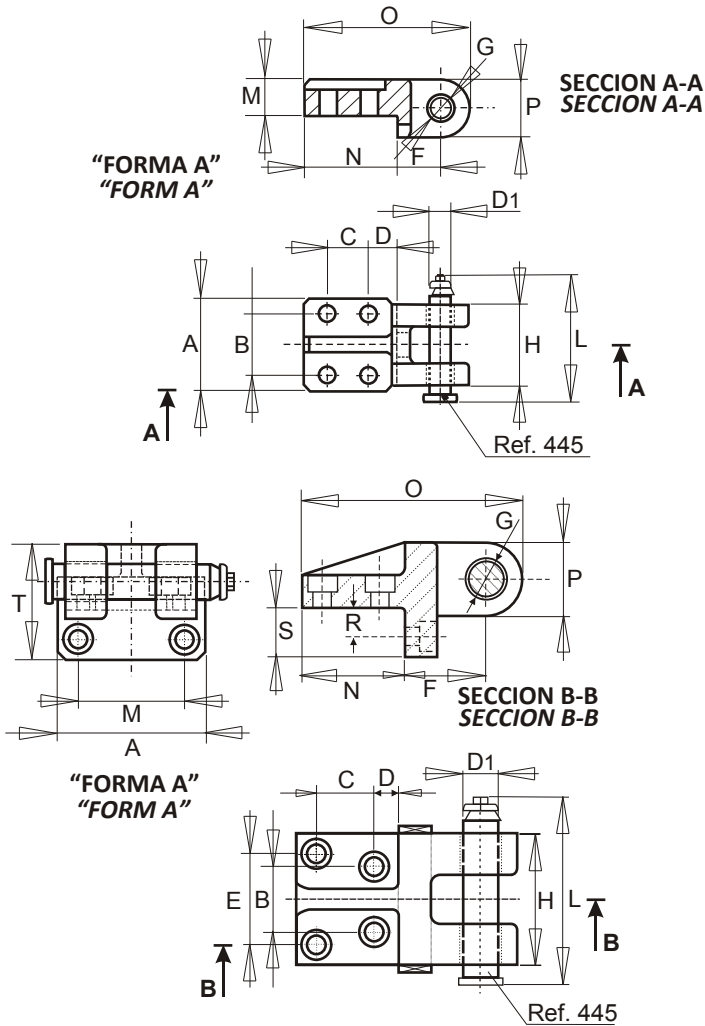

ATENCIÓN: Por razones de seguridad tener en cuenta que el peso del troquel o matriz, debe ser soportado por dos elementos.

WARNING: For safety reason, please consider always that the weight of the die has to be supported by just 2 lifting brackets.

MATERIAL: CK45
N/mm²: 800÷1000
Tornillos no incluidos.
Screws not included.

Carga max. Kg. Max. Load Kg.	Peso max. Matriz-troquel Max. Die Weight Kg.	A	B	C	D	D1	E	F	G	H	L	M	N	O	P	R	S	T	Forma Form	Tornillo DIN 912-8.8 Screw DIN 912-8.8
600	1200	80	50	40	22,5	15,6	--	39	16	70	102,5	32	80	145	52	--	--	--	A	M2x45
1000	2000	90	60	40	27,5	20,6	--	42	21	79	113,5	36	90	160	56	--	--	--	A	M16x55
2000	4000	100	65	65	32,5	25,6	--	60	26	90	128,5	50	120	215	70	--	--	--	A	M20x80
4000	8000	135	56	60	20	33	84	85	34	125	166,5	96	100	221	72	30	50	111	B	M16x45
7000	14000	180	80	70	30	43	110	100	44	160	210,5	130	125	270	90	35	60	140	B	M20x60

FORMA DE PEDIDO / ORDER FORM : ET6 x A

SOPORTE DE ELEVACION CON TORNILLO DE ELEVACION "ET7" RENAULT

RENAULT LIFTING BRACKET WITH LIFTING BOLT "ET7"

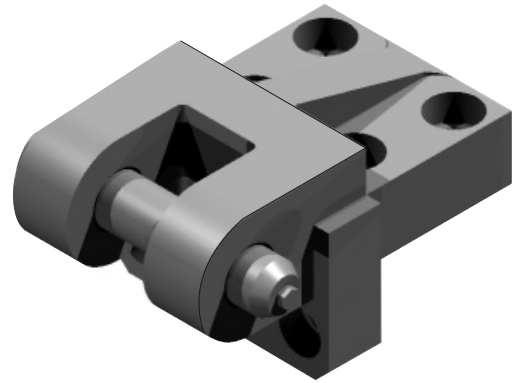
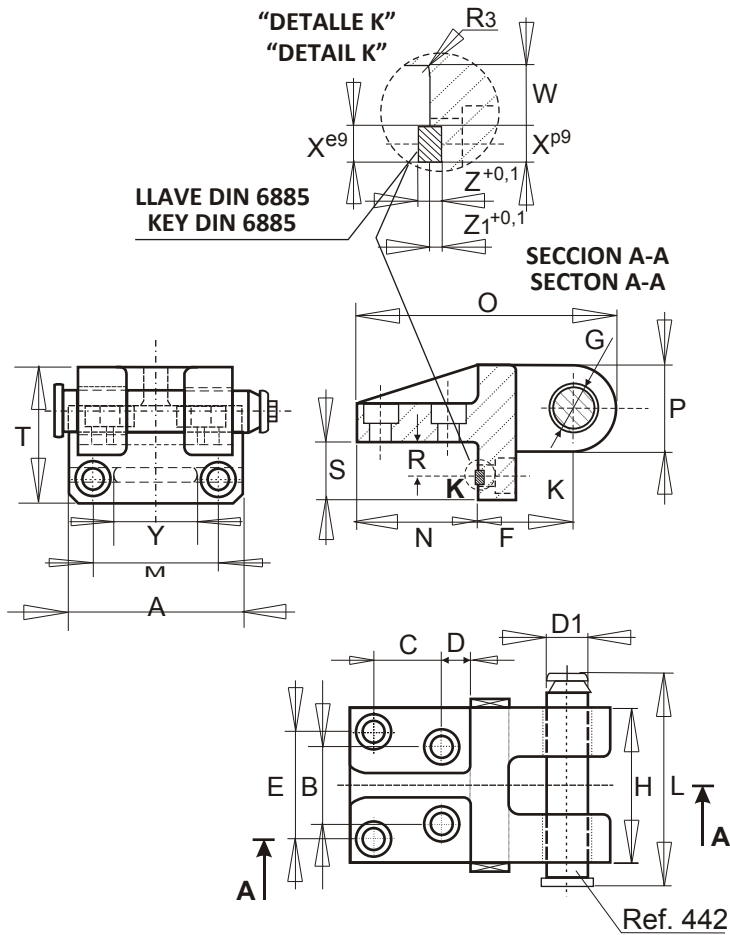

ATENCIÓN: Por razones de seguridad tener en cuenta que el peso del troquel o matriz, debe ser soportado por dos elementos.

WARNING: For safety reason, please consider always that the weight of the die has to be supported by just 2 lifting brackets.

MATERIAL: CK45
N/mm²: 800÷1000
Tornillos no incluidos.
Screws not included.

Carga max. Kg. Max. Load Kg.	Peso max. Matriz-troquel Max. Die Weight Kg.	A	B	C	D	D1	E	F	G	H	L	M	N	O	P	R	S	T	W	X	Y	Z	Z1	Tornillo DIN 912-8.8 Screw DIN 912-8.8
4000	8000	135	56	60	20	32	84	85	33	125	154	96	100	221	72	30	50	111	24	14	63	4,5	4,5	M16x45
6300	12600	180	80	70	30	40	110	100	41	160	197,5	130	125	270	90	35	60	140	27	16	100	5	5	M20x60

FORMA DE PEDIDO / ORDER FORM : ET7 x A

SOPORTE DE ELEVACION CON TORNILLO DE ELEVACION "ET8" BMW

BMW LIFTING BRACKET WITH LIFTING BOLT "ET8"

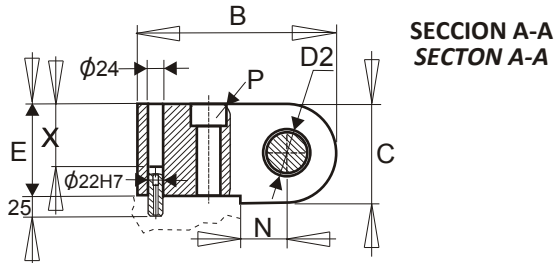

SECCION A-A
SECTION A-A

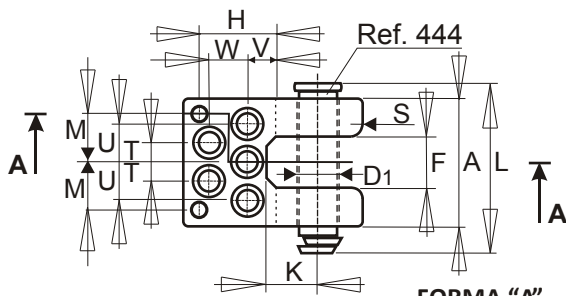

FORMA "A"
FORM "A"

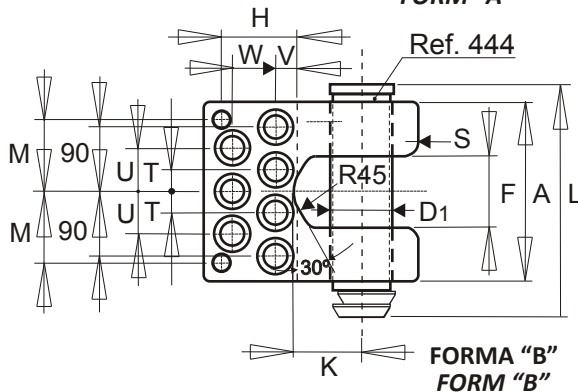

FORMA "B"
FORM "B"

MATERIAL: St52
Tornillos no incluidos.
Screws not included.



ATENCION: Por razones de seguridad tener en cuenta que el peso del troquel o matriz, debe ser soportado por dos elementos.

WARNING: For safety reason, please consider always that the weight of the die has to be supported by just 2 lifting brackets.

Carga max. Kg. Max. Load Kg.	Peso max. Matriz-troquel Max. Die Weight Kg.	D1	D2	A	B	C	E	F	H	K	L	M	N	P	S	T	U	V	W	X	Forma Form	Tornillo DIN 912-8.8 Screw DIN 912-8.8
3200	6400	30	32	126	185	80	75	50	85	50	158	45	40	12	16	20	40	30	35	40	A	M16x80
4500	9000	40	42	150	210	100	95	60	87	55	187	52	50	12	20	22,5	45	25	40	60	A	M20x100
8000	16000	50	52	175	240	120	115	75	95	70	220	62,5	60	16	24	25	50	35	45	80	A	M24x120
10000	20000	60	62	200	280	140	130	80	120	80	246	75	65	20	30	30	60	45	60	95	A	M30x140
18000	36000	80	82	250	300	160	150	100	105	95	305	100	90	20	30	30	60	30	60	115	B	M30x160

FORMA DE PEDIDO / ORDER FORM : ET8 x D1

SOPORTE DE ELEVACION CON TORNILLO DE ELEVACION "ET9" VDI 3366

VDI 3366 LIFTING BRACKET WITH LIFTING BOLT "ET9"

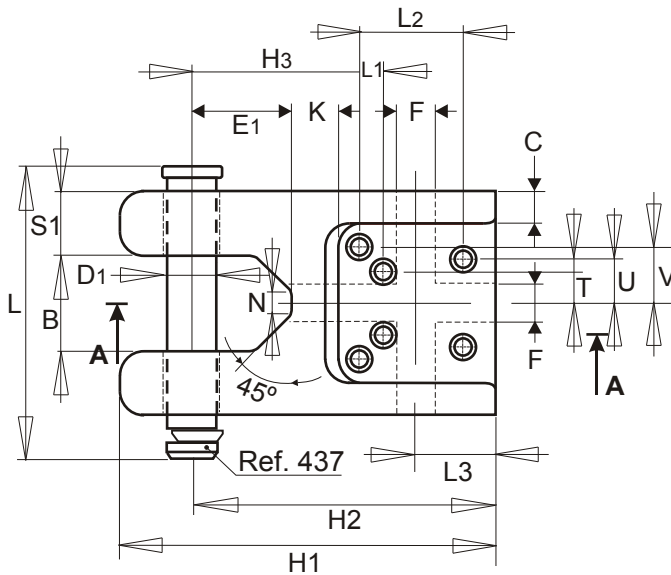
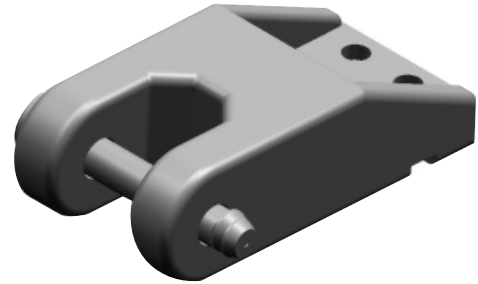
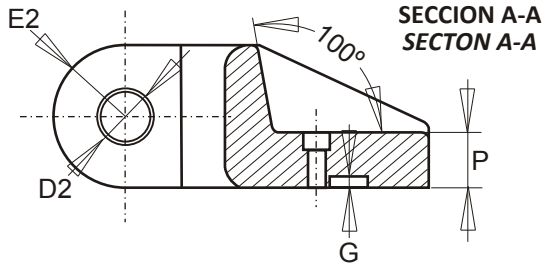

MATERIAL: St52
Tornillos no incluidos.
Screws not included.



ATENCION: Por razones de seguridad tener en cuenta que el peso del troquel o matriz, debe ser soportado por dos elementos.

WARNING: For safety reason, please consider always that the weight of the die has to be supported by just 2 lifting brackets.

Carga max. Kg. Max. Load Kg.	Peso max. Matriz-troquel Max. Die Weight Kg.	D1	D2	B	C	E1	E2	F	G	H1	H2	H3	N	K	L	L1	L2	L3	P	S1	T	U	V	Tornillo DIN 912-8.8 Screw DIN 912-8.8
3200	6400	32	34	60	20	63	40	25	7	260	220	125	28	37	175	30	85	45	40	40	25	30	30	M12x40
5000	10000	40	42	80	30	80	60	48	15	360	300	140	28	40	225	35	130	80	60	50	38	40	43	M16x75
8000	16000	50	52	100	30	100	60	48	15	380	320	160	28	40	273	35	130	85	70	60	40	55	55	M16x85
12500	25000	63	65	120	40	125	90	48	15	470	380	210	28	60	347	30	130	100	70	80	40	55	70	M20x90
18000	36000	76	78	140	40	160	90	64	20	510	420	250	45	60	422	20	135	100	90	100	50	75	100	M24x115
25000	50000	76	78	140	40	160	120	64	25	590	470	270	45	80	422	35	160	110	110	100	55	75	100	M30x140
31500	63000	76	78	140	40	160	130	64	25	600	470	270	45	80	422	35	160	110	120	100	55	75	100	M30x150

FORMA DE PEDIDO / ORDER FORM : ET9 x D1



SOPORTE DE ELEVACION CON TORNILLO DE ELEVACION "ET10"

LIFTING BRACKET WITH LIFTING BOLT "ET10"

SECCION A-A
SECTION A-A

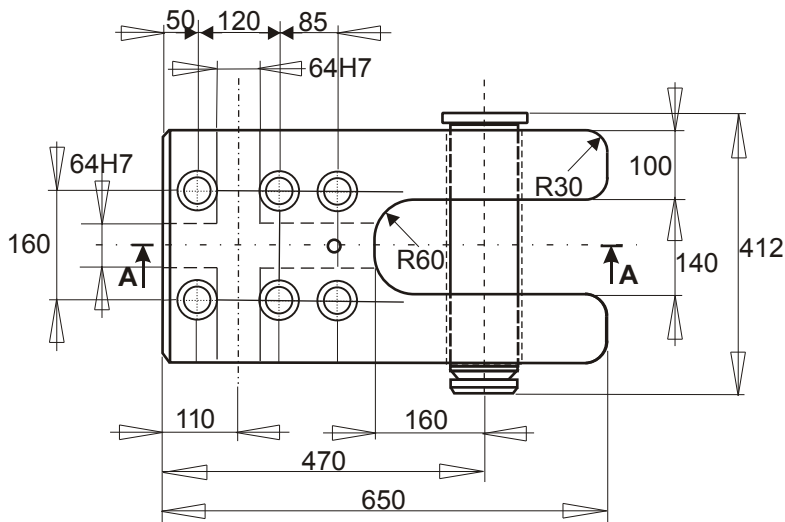
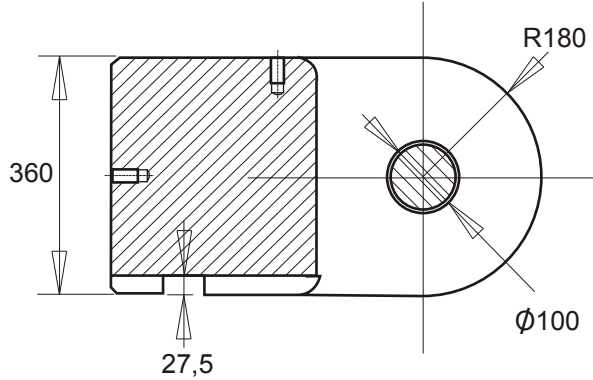

MATERIAL: 42CrMo4
Tornillos no incluidos.
Screws not included.

ATENCION: Por razones de seguridad tener en cuenta que el peso del troquel o matriz, debe ser soportado por dos elementos.

WARNING: For safety reason, please consider always that the weight of the die has to be supported by just 2 lifting brackets.

Carga max. Kg. Max. Load Kg.	Peso max. Matriz-troquel Max. Die Weight Kg.	Tornillo DIN 912 - 8.8 Screw DIN 912 - 8.8
42500	85000	M36x250

FORMA DE PEDIDO / ORDER FORM : ET10

PERNO TRANSPORTE VDI 3366

LIFTING PIN VDI 3366

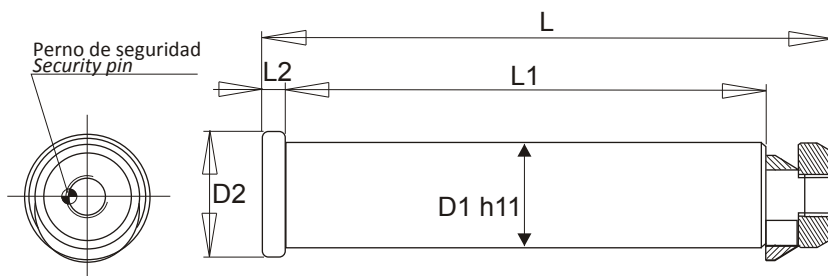
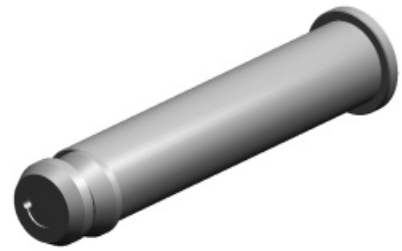
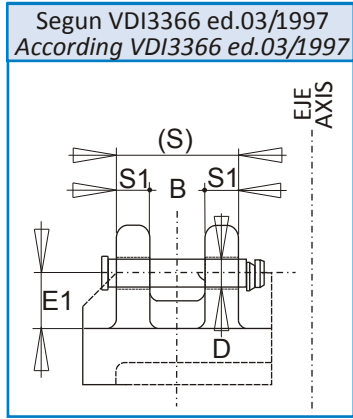

ATENCIÓN: Por razones de seguridad, por favor considerar siempre que el peso del troquel o matriz, tiene que ser soportado por dos pernos de transporte.

WARNING: For safety reason, please consider always that the weight of the die has to be supported by just 2 lifting pins.

Carga max. Kg. Max. Load Kg.	Peso max. Matriz-troquel Max. Die Weight Kg.	B	D	D1	D2	E1	L	L1	L2	S	S1	Mat.
3200	6400	60	34	32	40	63	175	145	10	140	40	CK45
5000	10000	80	42	40	50	80	225	188	10	180	50	CK45
8000	16000	100	52	50	60	100	273	230	11	220	60	CK45
12500	25000	120	65	63	75	125	347	295	14	280	80	CK45
18000	63000	140	78	76	95	160	422	360	15	340	100	42CrM04

FORMA DE PEDIDO / ORDER FORM : D1



PERNO TRANSPORTE VW LIFTING PIN VW

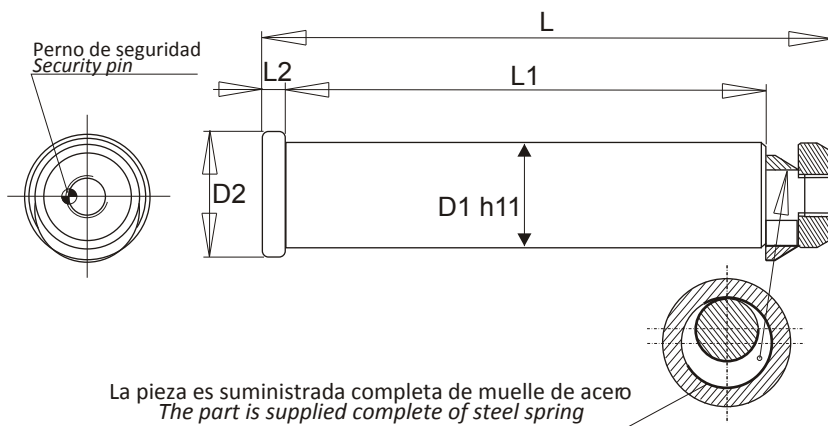
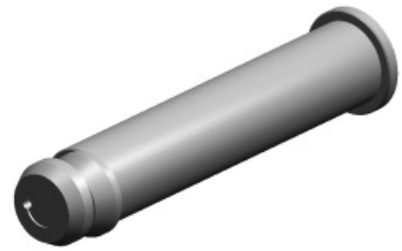
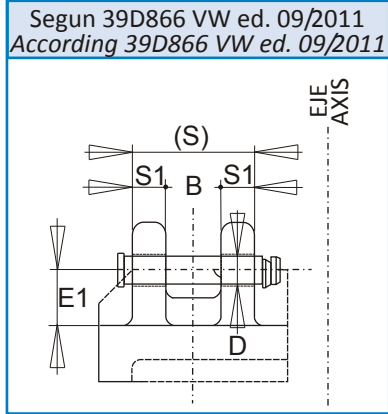

ATENCIÓN: Por razones de seguridad, por favor considerar siempre que el peso del troquel o matriz, tiene que ser soportado por dos pernos de transporte.

WARNING: For safety reason, please consider always that the weight of the die has to be supported by just 2 lifting pins.

Carga max. Kg. Max. Load Kg.	Peso max. Matriz-troquel Max. Die Weight Kg.	B	D	D1	D2	E1	L	L1	L2	S	S1	Mat.
3200	6400	60	34	32	40	63	175	145	10	140	40	CK45
5000	10000	80	42	40	50	80	225	188	10	180	50	CK45
8000	16000	100	52	50	60	100	273	230	11	220	60	CK45
12500	25000	120	65	63	75	125	347	295	14	280	80	CK45
31500	63000	140	78	76	95	160	422	360	15	340	100	42CrM04

FORMA DE PEDIDO / ORDER FORM : D1

PERNO TRANSPORTE FIAT LIFTING PIN FIAT

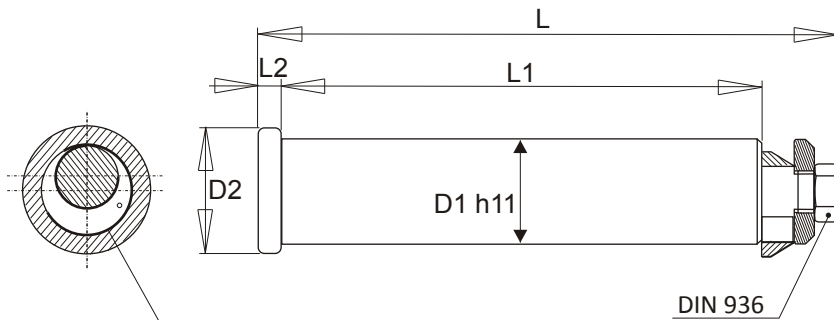
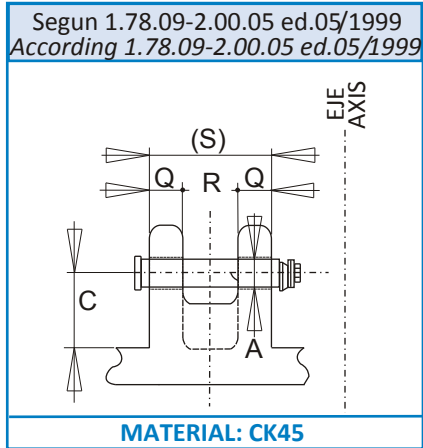

La pieza es suministrada completa de muelle de polipropileno
The part is supplied complete of polypropylene spring

ATENCIÓN: Por razones de seguridad, por favor considerar siempre que el peso del troquel o matriz, tiene que ser soportado por dos pernos de transporte.

WARNING: For safety reason, please consider always that the weight of the die has to be supported by just 2 lifting pins.

Carga max. Kg. Max. Load Kg.	Peso max. Matriz-troquel Max. Die Weight Kg.	Tipo Type	A	C	D1	D2	L	L1	L2	Q	R	S
2000	4000	---	30	60	29	38	178,5	150	6	40	60	140
3200	6400	---	35	65	33	43	200,5	170	6	50	60	160
5000	10000	---	45	85	43	53	233	195	8	50	80	180
8000	16000	---	55	105	53	65	282	235	10	60	100	220
8000	16000	C	55	75	53	65	227	180	10	50	65	165
12000	24000	---	65	130	63	78	352,5	295	12	80	120	280
13000	26000	C	65	100	63	78	272,5	215	12	60	80	200
30000	60000	---	81	150	78	95	421,5	355	14	100	140	340

FORMA DE PEDIDO / ORDER FORM : D1 x L



PERNO TRANSPORTE FORD LIFTING PIN FORD

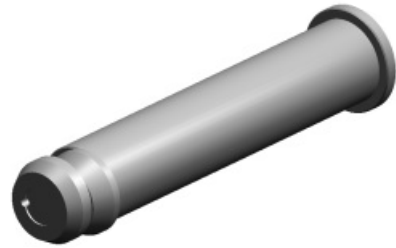
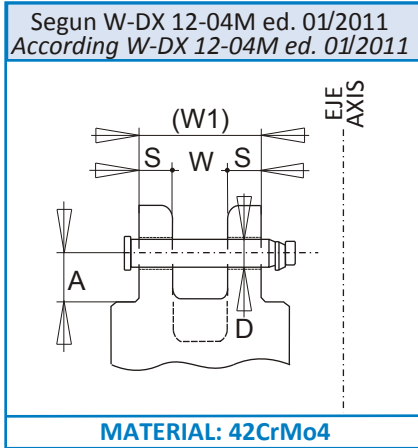

ATENCIÓN: Por razones de seguridad, por favor considerar siempre que el peso del troquel o matriz, tiene que ser soportado por dos pernos de transporte.

WARNING: For safety reason, please consider always that the weight of the die has to be supported by just 2 lifting pins.

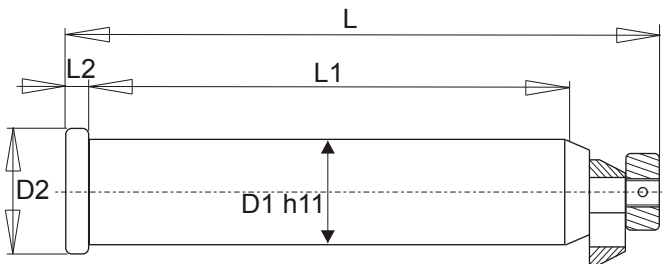

Carga max. Kg. Max. Load Kg.	Peso max. Matriz-troquel Max. Die Weight Kg.	A	D	D1	D2	L	L1	L2	S	W	W1
1500	3000	60	37	35	45	165	125	10	30	50	110
5000	10000	130	52	50	63	230	190	10	50	70	170
20000	40000	145	65	63	76	320	280	10	80	100	260
30000	60000	145	82	80	89	370	320	15	100	100	300

FORMA DE PEDIDO / ORDER FORM : D1



PERNO TRANSPORTE OPEL-GM

LIFTING PIN OPEL-GM

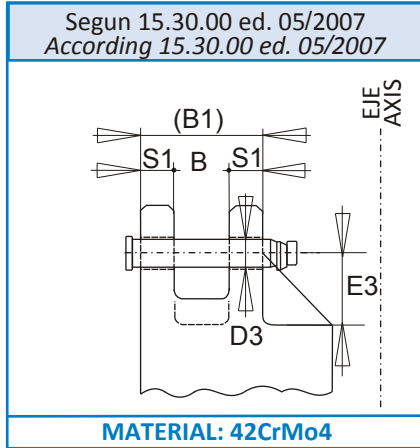

ATENCION: Por razones de seguridad, por favor considerar siempre que el peso del troquel o matriz, tiene que ser soportado por dos pernos de transporte.

WARNING: For safety reason, please consider always that the weight of the die has to be supported by just 2 lifting pins.

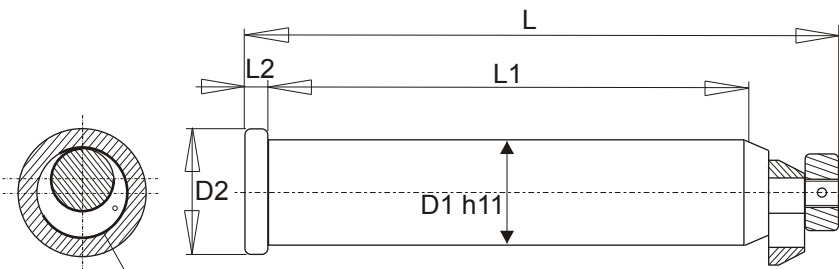

La pieza es suministrada completa de muelle de acero.
The part is supplied complete of steel spring.

Carga max. Kg. Max. Load Kg.	Peso max. Matriz-troquel Max. Die Weight Kg.	B	B1	D1	D2	D3	E3	L	L1	L2	S1
3400	6800	70	150	32	40	34	65	177	155	5	40
5650	11300	80	180	40	50	42	85	220	188	7	50
8950	17900	100	220	50	60	52	100	270	230	9	60
14350	28700	120	280	63	75	65	125	342	295	16	80
26700	53400	120	320	80	89	82	160	387	335	16	100

FORMA DE PEDIDO / ORDER FORM : D1



PERNO TRANSPORTE PSA-RENAULT

LIFTING PIN PSA-RENAULT

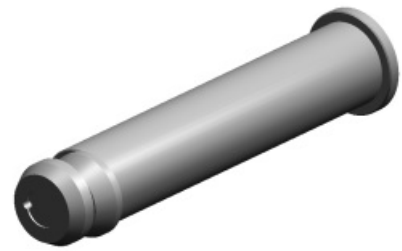
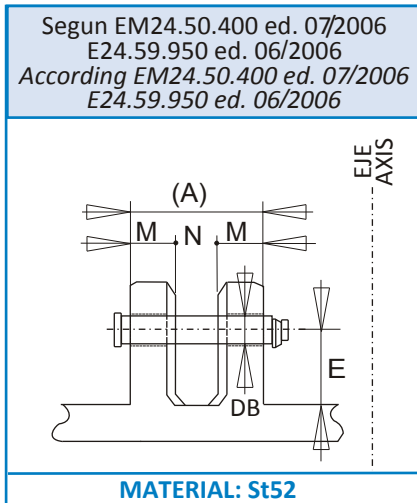

ATENCION: Por razones de seguridad, por favor considerar siempre que el peso del troquel o matriz, tiene que ser soportado por dos pernos de transporte.

WARNING: For safety reason, please consider always that the weight of the die has to be supported by just 2 lifting pins.

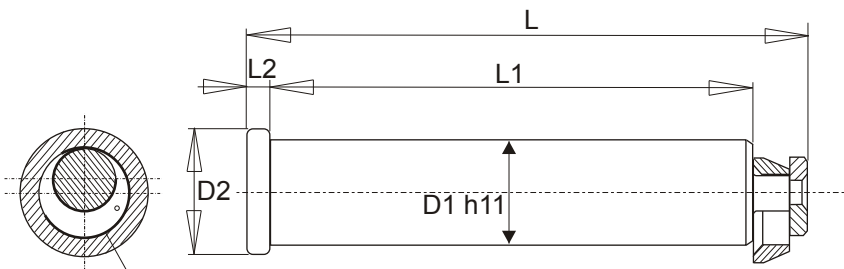

La pieza es suministrada completa de muelle de acero.
The part is supplied complete of steel spring.

Carga max. Kg. Max. Load Kg.	Peso max. Matriz-troquel Max. Die Weight Kg.	A	E	DB	D1	D2	L	L1	L2	M	N
6000	12000	125	55	34	32	40	154	132	6	37,5	50
9000	18000	160	70	42	40	50	197,5	170	8	47,5	65
14000	28000	200	90	52	50	63	247,5	212	10	60	80
22500	45000	250	100	65	63	80	309	265	12	75	100

FORMA DE PEDIDO / ORDER FORM : D1



PERNO TRANSPORTE VOLVO

LIFTING PIN VOLVO

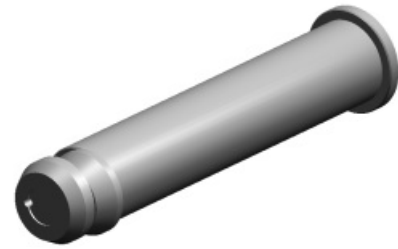
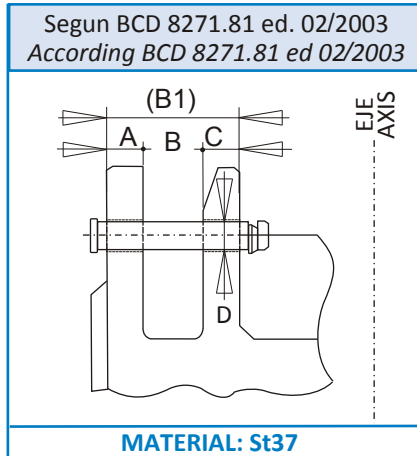

ATENCIÓN: Por razones de seguridad, por favor considerar siempre que el peso del troquel o matriz, tiene que ser soportado por dos pernos de transporte.

WARNING: For safety reason, please consider always that the weight of the die has to be supported by just 2 lifting pins.

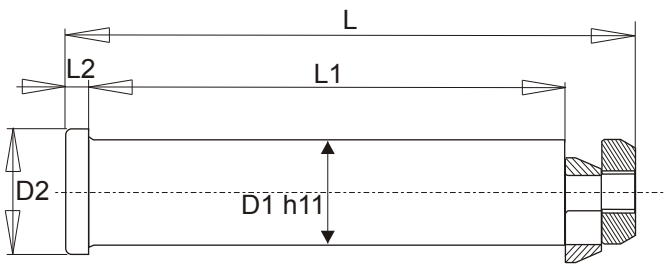

Carga max. Kg. Max. Load Kg.	Peso max. Matriz-troquel Max. Die Weight Kg.	Tipo Type	A	B	B1	C	D	D1	D2	E	L	L1	L2
2500	5000	--	40	65	155	50	42	40	50	100	195	160	8
8000	16000	C	60	100	220	60	65	63	75	125	285	230	14
12000	24000	--	80	100	260	80	65	63	75	125	327	275	14
20000	40000	--	100	120	320	100	82	80	95	180	402	340	15

FORMA DE PEDIDO / ORDER FORM : D1 x L



RECAMBIO PERNO DE TRANSPORTE PARA SOPORTE DE ELEVACION BMW

REPLACEMENT LIFTING PIN FOR LIFTING BRACKET BMW

MATERIAL: CK45

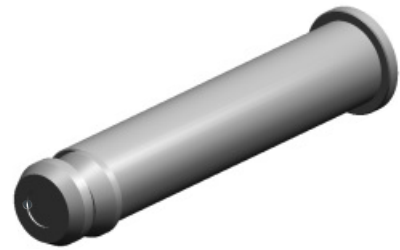
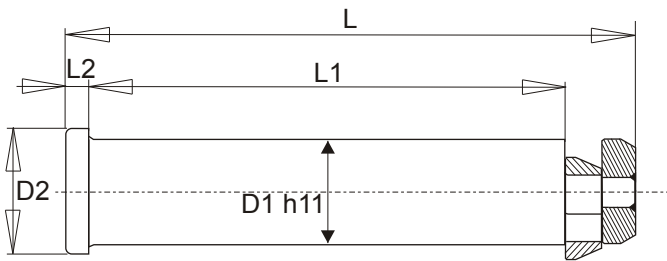

CE

Carga max. Kg. Max. Load Kg.	Peso max. Matriz-troquel Max. Die Weight Kg.	D1	D2	L	B1	L2
3200	6400	30	40	158	129	10
4500	9000	40	50	187	155	10
8000	16000	50	60	220	180	11
10000	20000	60	70	246	205	11
18000	36000	80	90	305	255	12

FORMA DE PEDIDO / ORDER FORM : D1

ATENCION: Por razones de seguridad, por favor considerar siempre que el peso del troquel o matriz, tiene que ser soportado por dos pernos de transporte.

WARNING: For safety reason, please consider always that the weight of the die has to be supported by just 2 lifting pins.



RECAMBIO PERNO DE TRANSPORTE PARA SOPORTE DE ELEVACION FIAT

REPLACEMENT LIFTING PIN FOR LIFTING BRACKET FIAT

MATERIAL: CK45

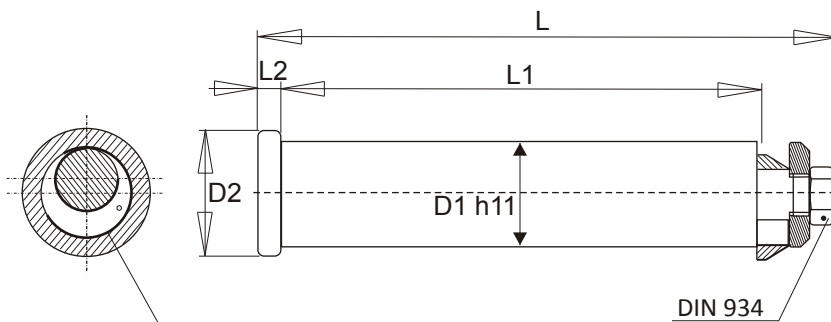

La pieza es suministrada completa de muelle de polipropileno
The part is supplied complete of polypropylene spring



CE

ATENCIÓN: Por razones de seguridad, por favor considerar siempre que el peso del troquel o matriz, tiene que ser soportado por dos pernos de transporte.

WARNING: For safety reason, please consider always that the weight of the die has to be supported by just 2 lifting pins.

Carga max. Kg. Max. Load Kg.	Peso max. Matriz-troquel Max. Die Weight Kg.	D1	D2	L	L1	L2
600	1200	15,6	25	102,5	77	6
1000	2000	20,6	30	113,5	86	6
2000	4000	25,6	35	128,5	100	6
4000	8000	33	43	166,5	135	6
7000	14000	43	53	210,5	175	8

FORMA DE PEDIDO / ORDER FORM : D1



CINTA DE PRECISION EN ESTUCHE CASE GAUGED STRIP BAND

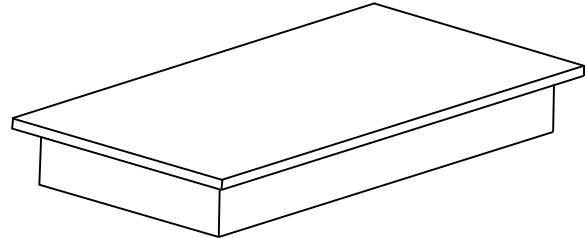
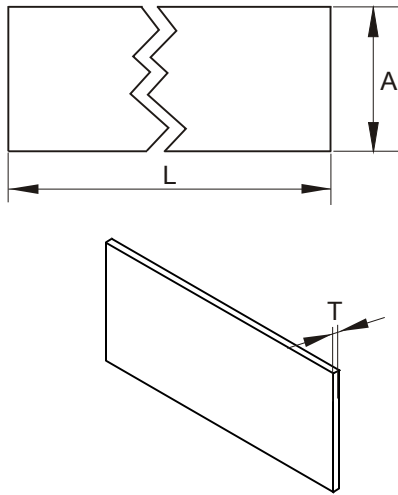

MATERIAL : 1.1274 Acero Carbono / Carbon Steel
1.4310 Acero Inoxidable / Stainless Steel

T	Tol.	Resist.	A x L			
			25x300	50x300	100x500	150x500
Material			1.1274	1.1274	1.4310	1.4310
Nº Hojas Nº of Strips			10	10	5	5
0.01	±0.002	1.600 - 1.800	*	*	*	
0.02			*	*		
0.025						*
0.03			*	*		
0.04			*	*		
0.05	±0.003	1.400 - 1.600	*	*	*	*
0.06			*	*		
0.07			*	*		
0.075						*
0.08			*	*		
0.09	±0.004	1.400 - 1.600	*	*	*	
0.10			*	*		*
0.12				*		
0.15			*	*	*	*
0.18				*		
0.20	±0.006	1.400 - 1.600	*	*	*	*
0.25			*	*	*	*
0.30			*	*	*	*
0.35				*	*	*
0.40			*	*	*	*
0.45				*	*	*

T	Tol.	Resist.	A x L			
			25x300	50x300	100x500	150x500
Material			1.1274	1.1274	1.4310	1.4310
Nº Hojas Nº of Strips			10	10	5	5
0.50	±0.010	1.600 - 1.800	*	*	*	*
0.55					*	
0.60			*	*	*	*
0.65					*	
0.70			*	*	*	*
0.75	±0.012	1.400 - 1.600			*	
0.80			*	*	*	*
0.85					*	
0.90			*	*	*	*
0.95					*	
1.00	±0.013	1.400 - 1.600	*	*	*	*
1.10					*	
1.20					*	
1.30					*	
1.40					*	
1.50	±0.020	1.400 - 1.600			*	
1.60					*	
1.70					*	
1.80					*	
1.90					*	
2.00					*	

FORMA DE PEDIDO / ORDER FORM : T x A x L x Material



CINTA DE PRECISION EN ROLLO

SPOOLED GAUGED STRIP

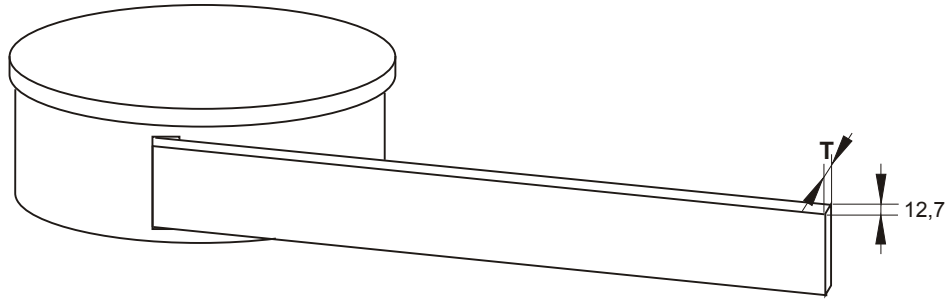

MATERIAL : 1.1274 Acero Carbono / Carbon Steel
1.4310 Acero Inoxidable / Stainless Steel

T	Tol.	Resist.	L			
			1m.	2m.	5m.	10m
Material			1.1274	1.1274	1.4310	1.1274
0.005	±0.002 - 0.003	2.000 - 2.200	*	*	*	*
0.01			*	*	*	*
0.02			*	*	*	*
0.03			*	*	*	*
0.04			*	*	*	*
0.05			*	*	*	*
0.06	±0.003 - 0.004	2.000 - 2.200	*	*	*	*
0.07			*	*	*	*
0.08			*	*	*	*
0.09			*	*	*	*
0.10			*	*	*	*
0.12	±0.004 - 0.007	1.400 - 1.600	*	*	*	*
0.15			*	*	*	*
0.18			*	*	*	*
0.20			*	*	*	*
0.25			*	*	*	*
0.30			*	*	*	*
0.35	±0.007 - 0.010	1.400 - 1.600	*	*	*	*
0.40			*	*	*	*
0.45			*	*	*	*
0.50			*	*	*	*

T	Tol.	Resist.	L			
			1m.	2m.	5m.	10m
Material			1.1274	1.1274	1.4310	1.1274
0.55	±0.0010	1.600 - 1.800	*	*	*	*
0.60			*	*	*	*
0.65			*	*	*	*
0.70			*	*	*	*
0.75			*	*	*	*
0.80			±0.013	1.400 - 1.600	*	*
0.85	*	*			*	*
0.90	*	*			*	*
0.95	*	*			*	*
1.00	*	*			*	*
1.10	±0.017	1.400 - 1.600	*	*	*	*
1.20			*	*	*	*
1.30			*	*	*	*
1.40			*	*	*	*
1.50			*	*	*	*
1.60			±0.020	1.400 - 1.600	*	*
1.70	*	*			*	*
1.80	*	*			*	*
1.90	*	*			*	*
2.00	*	*			*	*

FORMA DE PEDIDO / ORDER FORM : T x L x Material



CINTA DE PRECISION EN ROLLO ANCHO VARIABLE VARIABLE WIDTH SPOOLED GAUGED STRIP

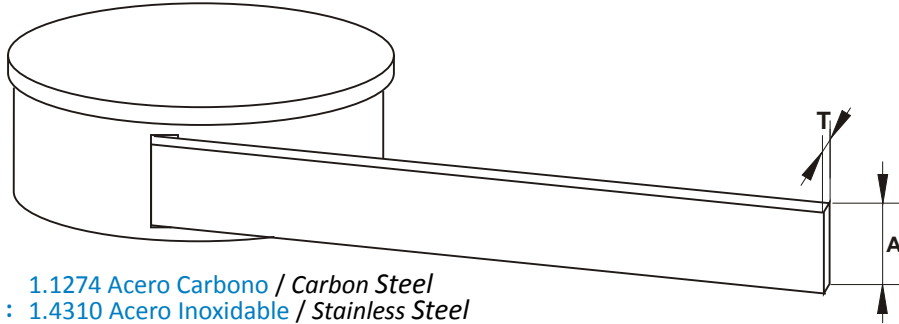

MATERIAL : 1.1274 Acero Carbono / Carbon Steel
1.4310 Acero Inoxidable / Stainless Steel
Latón / Brass

T	Tol.	Resist.	L	A							
				6	25	50	100	150	150	305	
Material				1.1274	1.1274	1.4310	1.4310	1.4310	Latón Brass	Latón Brass	
0.01	±0.003 - 0.003	2.000 - 2.200	5.000		*	*					
0.02					*	*	*				
0.025								*	*		
0.03					*	*					
0.04					*	*					
0.05	±0.004 - 0.004	2.000 - 2.200	5.000	*	*	*	*	*	*	*	
0.06					*	*					
0.07					*	*					
0.075								*	*		
0.08					*	*	*				
0.09	±0.003 - 0.010	2.000 - 2.200	5.000		*	*					
0.10					*	*	*	*	*	*	
0.12							*				
0.15					*	*	*	*	*	*	
0.18							*				
0.20	±0.007 - 0.010	1.400 - 1.600	5.000	*	*	*	*	*	*	*	
0.25					*	*	*	*	*	*	
0.30					*	*	*	*	*	*	
0.35							*	*			
0.40					*	*	*	*	*	*	
0.45	±0.010 - 0.010	1.400 - 1.600	5.000			*	*				
0.50					*	*	*	*	*	*	
0.55							*	*	*	*	
0.60							*	*	*	*	
0.65							*	*	*	*	
0.70	±0.010 - 0.010	1.600 - 1.800	5.000		*	*	*	*	*		
0.75					*	*	*	*	*	*	
0.80					*	*	*	*	*	*	
0.85							*	*	*	*	
0.90					*	*	*	*	*	*	
0.95	±0.013 - 0.013	1.400 - 1.600	5.000				*				
1.00					*	*	*	*	*	*	

FORMA DE PEDIDO / ORDER FORM : T x A x Material



SURTIDO DE CINTA DE PRECISION SELECTION OF GAUGED STRIP

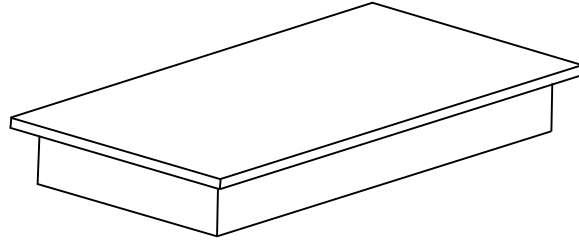
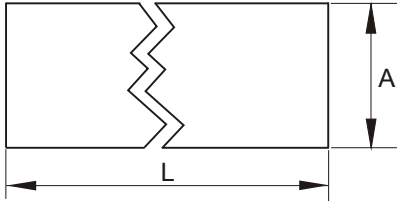

1.1274 Acero Carbono / Carbon Steel
MATERIAL : 1.4310 Acero Inoxidable / Stainless Steel
 Latón / Brass

A x L	nº Hojas Nr. Strips	Material	Contenido / Content
100x500	9	1.4310	0.02/0.05/0.10/0.15/0.20/0.30/0.40/0.50/1.00
100x500	11	1.4310	0.02/0.05/0.10/0.15/0.20/0.25/0.30 0.35/0.40/0.45
100x500	11	1.4310	0.50/0.55/0.60/0.65/0.70/0.75/0.80 0.85/0.90/0.95/1.00
150x500	10	1.4310	0.025/0.05/0.075/0.10/0.15/0.20/0.25 0.30/0.40/0.50
150x500	10	Latón Brass	0.025/0.05/0.075/0.10/0.15/0.20/0.25 0.30/0.40/0.50
25x300	21	1.1274	0.01/0.02/0.03/0.04/0.05/0.06/0.07/0.08/0.09 0.10/0.15/0.20/0.25/0.30/0.40/0.50/0.60/0.70 0.80/0.90/1.00
50x300	25	1.1274	0.01/0.02/0.03/0.04/0.05/0.06/0.07/0.08/0.09 0.10/0.12/0.15/0.18/0.20/0.25/0.30/0.35/0.40 0.45/0.50/0.60/0.70/0.80/0.90/1.00
50x300	23	1.1274	0.03/0.04/0.05/0.06/0.07/0.08/0.09/0.10/0.12 0.15/0.18/0.20/0.25/0.30/0.35/0.40/0.45/0.50 0.60/0.70/0.80/0.90/1.00
50x300	11	1.1274	0.02/0.03/0.05/0.10/0.15/0.20/0.25/0.30/0.40 0.50/1.00

FORMA DE PEDIDO / ORDER FORM : A xL x Material



COLUMNA DE APOYO SUPPORT PILLAR

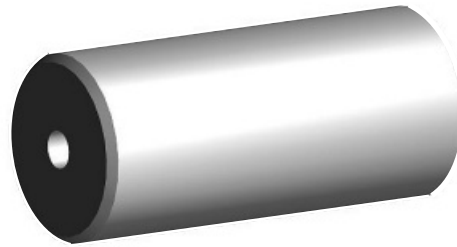
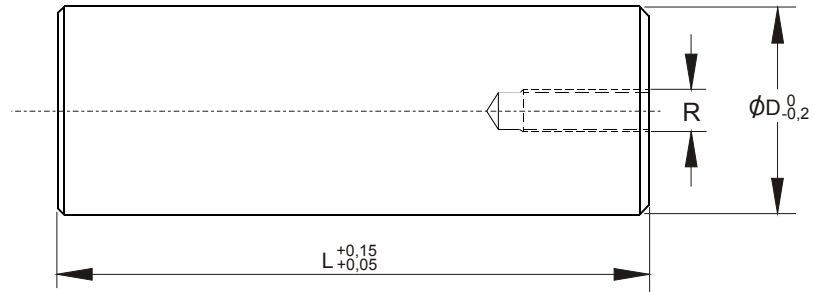

MATERIAL : Acero para trabajo en frío / Alloy cold formed steel

D	R	L						
		50	60	70	90	110	120	150
30	M10	*	*	*	*	*		
40	M10	*	*	*	*	*		
50	M10	*	*	*	*	*		
60	M12		*	*	*	*	*	
80	M12			*	*	*	*	*
100	M16			*	*	*	*	*

FORMA DE PEDIDO / ORDER FORM : CA / D x L