

# A

# Ballscrew Failure Analysis

## A1 Preface

In recent years, more and more ballscrews are installed in various machines to meet the requirements of higher accuracy and better performance. Ballscrews become one of the most widely used power transmission components. In CNC machines, ballscrews help improve their positioning accuracy and elongate their service life. Ballscrews are also increasingly used to replace ACME screws in manually operated machines.

A ballscrew is normally preloaded to minimize the backlash of machine movement. Even a high precision ballscrew will not provide good accuracy and long service life if it is not installed properly.

This article discusses primary ballscrew problems and their precautions. Some measuring procedures are also discussed to help users locate the cause of an abnormal backlash.

## A2 The Cause and Precautions of Ballscrew Problems

Three major categories of ballscrew problems and their precautions are discussed as follows.

### A2-1 Too much play

#### 1. No preload or insufficient preload :

The ball nut will rotate and move downward by its own weight when a non-preloaded ballscrew is held vertically with the screw spindle constrained. A significant backlash may exist in a non-preloaded ballscrew unit. Therefore non-preload ballscrews are only used in the machinery, where low operation resistance but not positioning accuracy is the major concern.

HIWIN can determine the correct amount of preload based on different applications. We can also preset the amount of preload before shipment. Be sure to clearly specify the operation condition of your application when you order a ballscrew unit.

#### 2. Too much torsional displacement :

(1) Incorrect heat treatment, hardened layer too thin, non-homogeneous hardness distribution, or material too soft:

Standard hardness of steel balls, ball nuts, and screw spindles are HRC 62-66, 58-62, and 58-62, respectively.

(2) Incorrect design-L/D ratio too high, etc:

The lower the L/D (length/diameter) ratio, the more rigid the spindle is. L/D ratio should be limited to under 60.

(The accuracy grade related to this L/D range is shown in Table 4.10) There will be a significant deflection (torsional displacement )

if the L/D ratio is too high. The ballscrew installation shown in Fig A-1

is supported at one end only. This kind of "non-rigid" design should be avoided if possible.

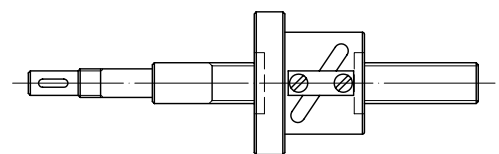

Fig. A-1 The installation of ballscrews.

#### 3. Inappropriate bearing selection :

Angular ball bearings should be used in ballscrew installation. A ball bearing with high pressure angle specially designed for ballscrew installation is even a better choice. A regular deep groove ball bearing will generate a significant amount of axial play when axially loaded. It should not be used in this application.

#### 4. Inappropriate bearing installation :

(1) If the bearing is not attached to the screw spindle properly, it would cause axial play under load. This problem may be caused by the bearing journal of the screw spindle being too long or the non-threaded part of the screw spindle being too short.

- (2) The perpendicularity between the bearing seating face and the thread axis of the bearing locknut on the ballscrew, or the parallelism between the opposite faces of the locknut is out of tolerance causing the bearing to tilt. The thread for bearing lock nut and the seating face of a bearing in the ballscrew journal should be machined in one setting to ensure the perpendicularity. It is even better if they can be ground.
- (3) Two lock nuts and a spring washer should be used in the bearing installation to prevent them from getting loose in operation.

**5. The ball nut housing or the bearing housing is not rigid enough :**

The ball-nut-mounted housing or the bearing-mounted housing may deflect under components' weight or machining load if it is not rigid enough. The test illustrated in Fig A-4 (d) can be used to check the rigidity of the ball-nut-mounted housing. Similar test can be used to check the rigidity of the bearing-mounted housing.

**6. The ball nut housing or the bearing housing is not mounted properly :**

- (1) Components may become loose due to vibration or lack of locating pin(s). Solid pins instead of spring pins should be used for locating purpose.
- (2) Ball-nut-seated screws are not seated firmly because the screws are too long or the thread holes on housing are too short.
- (3) Ball-nut-seated screws become loose due to vibration and lack of a spring washer.

**7. Parallelism or flatness of the housing surface is out of tolerance :**

In a machine assembly, a shim bar is frequently located between the housing location surface and the machine body for adjustment purpose. The clearance of table movement may vary at different locations if the parallelism or flatness of any matching component is out of tolerance no matter they are ground or scraped.

**8. The motor and the ballscrew spindle are not assembled properly :**

- (1) There will be a relative rotation between the motor shaft and the ballscrew spindle if the connecting coupling is not installed firmly or the coupling itself is not rigid enough.
- (2) Driving gears are not engaged properly or driving mechanism is not rigid. A timing belt should be used to prevent slipping if the ballscrew is to be driven by a belt.
- (3) Key is loose in the groove. Any inappropriate match among the hub, key, and key seat may cause these components to generate backlash.

## **A2-2 Unsmooth operation**

**1. Defects from ballscrew manufacturing :**

- (1) The track surface of the ballscrew spindle or the ball nut is too rough.
- (2) The roundness of the bearing balls, the ball nut or the ballscrew spindle is out of tolerance.
- (3) The lead or the pitch circle diameter of the ball nut / the spindle is out of tolerance.
- (4) The return tube is not attached to the ball nut appropriately.
- (5) Uneven bearing ball size or hardness. The above problems should not be found in the manufacturers of top quality.

**2. Foreign objects enter the ball path :**

- (1) Packing material is trapped in the ball path. Various materials and anti-rust paper are normally used to pack ballscrew units for shipment. It is possible to have these foreign materials or other objects trapped in the ball path if proper procedures are not done while installing or aligning the ballscrew unit. This may cause the bearing balls to slide instead of rolling or even cause the ball nut to jam up completely.
- (2) Machined chips get in the ball track. The chips or dust generated during machining processes may be trapped in the bearing ball track if wiper kits are not used to keep them away from the surface of the ballscrew unit. This may cause unsmooth operation, deteriorate accuracy and reduce service life.

### **3. Over-travel :**

Over-travel can damage the return tube and cause it to collapse or even break. When this happens, the bearing balls will not circulate smoothly. They may break and damage the groove on the ball nut or the ballscrew spindle under severe circumstances. Over-travel may happen during set-up or as the result of a limit switch failure or a machine collision. To prevent further damage, an over-traveled ballscrew should be checked or repaired by the manufacturer before it goes back to service.

### **4. Damaged return tube:**

The return tube may collapse and cause the same problems as mentioned above if it is hit heavily during installation.

### **5. Misalignment:**

Radial load exists if the center line of the ball nut's housing and the screw spindle's bearing support housing are not aligned properly. The ballscrew unit may bend if this misalignment is too big. An abnormal wear may still happen even if the misalignment is not significant enough to cause a noticeable bending. The accuracy of a ballscrew unit will deteriorate rapidly if it is misaligned. The higher the preload is set in the nut, the more demanding the alignment accuracy is required in the ballscrew.

### **6. The ball nut is not mounted properly on the nut housing:**

Eccentric load exists when the mounted ball nut is tilted or misaligned. If this is the case, the motor current may fluctuate during rotation.

### **7. Ballscrew unit is damaged during transportation**

## **A2-3 Fracture**

### **1. Broken bearing ball :**

Cr-Mo steel is the most commonly used material for bearing balls. It takes about 1,400kg (3,080LB) to 1,600kg (3,520LB) to break a steel ball of 3.175 mm (1/8 in) diameter. The temperature of an under-lubricated or non-lubricated ballscrew raises substantially during operation. This temperature raise could make the bearing balls brittle or break which cause damage to the grooves of the ball nut or the ballscrew spindle consequently.

Therefore, lubricant replenishment should be considered during the design process. If an automatic lubricating system is not available, a periodical grease replenishment should be scheduled as part of maintenance program.

### **2. Collapsed or broken return tube :**

Over-travel of the ball nut or an impact on the return tube could cause the return tube to collapse or break. This may block the path of bearing balls and cause them to slide instead of rolling and break eventually.

### **3. Ballscrew spindle end breaks :**

- (1) Inappropriate design: Sharp corners on the ballscrew spindle should be avoided to reduce local stress concentration. (Fig. A2) shows some of the appropriate screw end designs.
- (2) Bend of screw spindle journal: The seating surface of the bearing of the ballscrew and the thread axis of the bearing's lock nut are not perpendicular to each other or the opposite sides of the lock nut are not parallel to each other. This will cause the end of screw spindle to bend and eventually break. The amount of deflection at the end of the ballscrew spindle (Fig A-3) before and after the bearing's lock nut being tightened should not exceed 0.01 mm (0.0004 in).
- (3) Radial force or fluctuating stress: Misalignment in the ballscrew installation creates abnormal fluctuating shear stress and causes the ballscrew to fail prematurely.

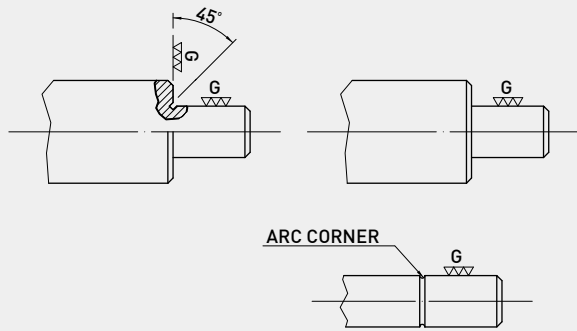

Fig A-2 The design of ballscrew spindle end

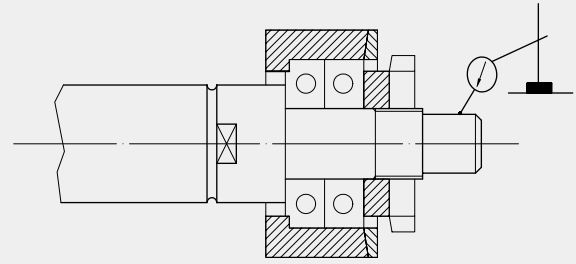

Fig A-3 The Deflection of Ballscrew Spindle

### A3 Locating the Cause of an Abnormal Backlash

The following measurement procedures can be performed to locate the cause of an abnormal backlash in the ballscrew installation.

1. Glue a gauge ball in the center hole at one end of the screw spindle. Use the flat plate of a dial indicator to check the axial movement of this gauge ball in axial direction while rotating the screw spindle (Fig A-4(a)). The movement should not exceed 0.003mm (0.00012 in), if the bearing hub, the ball nut, and the ball nut housing are all installed properly.
2. Use a dial indicator to check the relative movement between the bearing housing and the bearing seat while rotating the ballscrew (Fig A-4(b)). Any dial indicator reading other than zero indicates that either the bearing hub is not rigid enough or it is not installed properly.
3. Check the relative movement between the machine table and the ball nut housing (Fig A-4(c)).
4. Check the relative movement between the ball nut housing and the ball nut flange (Fig A-4(d)).

Contact the ballscrew manufacturer if an unsatisfactory backlash still exists while all the above checks are ok. The preload or the rigidity of the ballscrew may have to be increased.

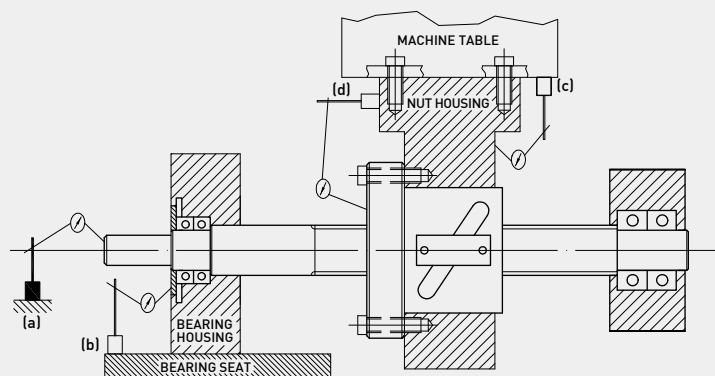

Fig. A-4 Locating the Cause of an Abnormal Backlash