

# Clutches and Brakes



# Contents

**Sizing & Selection**..... page 3

## Clutch / Brake Combinations

### Electro-Magnetic Clutches - Single Disc

SFM VAR 00.....	page 6
SFM VAR 10.....	page 8
SFM VAR 01.....	page 10
SFM VAR 11.....	page 11
E210 VAR 00.....	page 12
E210 VAR 02.....	page 14
E220 VAR 00.....	page 16
E220 VAR 02.....	page 18
E220 VAR 05.....	page 20
E220 VAR 06.....	page 22

### Electro-Magnetic Clutches - Multi Disc

E140 VAR 00.....	page 24
------------------	---------

### Electro-Magnetic Clutches - Tooth

E320 VAR 00 / VAR 10 / VAR 04 / VAR 14	page 26
E320 VAR 504.....	page 28
E320 VAR 05 / VAR 15.....	page 30
E330 VAR 04 / VAR 14.....	page 32
E330 VAR 504.....	page 34
E330 VAR 05 / VAR 15.....	page 36

### Pneumatic Clutches - Multi Disc

P130 VAR 00 / VAR 02.....	page 38
P140 VAR 00 / VAR 02.....	page 40

### Pneumatic Clutches - Tooth

P310 VAR 00.....	page 42
------------------	---------

### Hydraulic Clutches - Multi Disc

H110 VAR 00.....	page 44
------------------	---------

## Torque Limiters

### Mechanical Torque Limiter - Multi Disc

L310 VAR 02.....	page 46
L331 VAR 00.....	page 48
L331 VAR 05.....	page 50

## Brakes

### Electro-Magnetic Brakes - Single Disc

PBM VAR 00.....	page 52
PBM VAR 01.....	page 54
PBM VAR 02.....	page 55
E510 VAR 00.....	page 56
E520 VAR 00.....	page 58

### Electro Release Brakes - Single Disc

ERD VAR 00 / VAR 02 / VAR 03	
size 005 – 300.....	page 60
How to order	
size 005 – 300.....	page 62
ERD VAR 00	
size 500 – 3200.....	page 64
ERD VAR 03	
size 500 – 12800.....	page 66

### Electro Release Brakes - Dual Disc

ERDD VAR 00 / VAR 02	
size 120 – 6400.....	page 68
ERDD VAR 00 / VAR 02 / VAR 03	
size 120 – 25600.....	page 70
How to order	
size 120 – 25600.....	page 72

### Electro-Magnetic Brakes - Tooth

E710 VAR 00.....	page 74
E720 VAR 00.....	page 76

### Pneumatic Brakes - Single Disc

P520 VAR 00.....	page 78
------------------	---------

### Pneumatic Brakes - Dual Disc

P620 VAR 00.....	page 80
------------------	---------

### Centrifugal Brakes

FC-G - C410.....	page 82
------------------	---------

### Hydraulic Brakes - Multi Disc

H420 VAR 00 / VAR 01.....	page 84
---------------------------	---------

**Power Supplies**..... page 86

**Your REQUIREMENTS**..... page 90

## Customised Models

More than 60% of today's production is customized to meet specific client demands. If we cannot fulfil your requirements in any way with our standard product, such as bore size, improved IP ratings, quiet brakes, mounting configurations, more torque ... call us!

## DECLARATION OF CE CONFORMITY AND INCORPORATION

WE: WARNER ELECTRIC EUROPE S.A.S.  
7, rue Champfleury, BP 20095, F-49182 St Barthélemy d'Anjou Cedex

Declare under our sole responsibility that all products in this catalogue are exclusively designed for incorporation into a machine or to be assembled with other machines to create a machine. The operation of the product is submitted to the conformity of the complete equipment, following the provisions of the machinery directive 89/392/EEC and if electric to the EMC directive 89/336/EEC. The conformity of the electric units to the Low Voltage directive 73/23/EEC is supported by the full respect of the following standards: NFC 79300 and VDE 0580/8.65

The products presented in this catalogue have not been designed to be used according to directive 94/9/EC (equipment for explosive atmosphere (ATEX)). Feel free to submit your inquiries.

# Clutches and Brakes Sizing and Selection

The sizing of a Warner Electric clutch or brake depends on various factors. The most common of these factors are shown below in chronological order:

- Transmissible torque: In Nm
- Energy source: Electric, Pneumatic, Hydraulic, or Mechanical
- Actuation mode: Static or Rotating
- Operational environment: Oil, Dry or Mixed
- Heat dissipation: Duty Cycle, Inertia, Speed, etc.
- Orientation of mounting: Horizontal, Vertical, Inclined

The majority of applications can be computed using the formulas and calculation methods given below. For special cases we recommend that you contact the factory.

## Transmissible Torque

Calculation of the torque provides a first approximation of the size of Warner Electric device required. The various transmissible torque's are:

### Static Torque

The maximum transmissible torque when components to be coupled are in synchronism (zero relative speed).

### Dynamic Torque

This is the torque developed by a clutch or brake during acceleration or deceleration until zero relative speed between the driving and driven component is achieved. This torque is a variable, as a function of the rotational speed, the friction factor, the type of friction material used, the operating ambient and the acceleration or deceleration time required to obtain the desired rotational speed.

### Residual Torque

Normally applies for multi-disc devices only. This torque results from the friction between internal and external discs in a non-energized device.

### Nominal Torque

The nominal torque of a power source can be calculated utilizing the following formula:

$$M_n = 9550 \cdot P / n$$

where:

- $M_n$  = required torque in Nm
- $P$  = power in kW
- $n$  = speed in  $\text{min}^{-1}$

### Calculation for Clutch Torque

In case the nominal torque is unknown, it is recommended to add a safety factor K as a function of the type of drive source and the coupling mode: single disc, multi-disc or tooth. This results in formula:

$$M_n = (9550 \cdot P / n) \cdot K$$

For quick selection based on drive power use  $K =$  :

- 2,5 - 3 for electric motors
- 4 - 5 for Diesel engines
- 5 - 6 for compressors

**Method to determine the transmission torque for a Warner Electric clutch or brake.** This method enables you to proceed on the basis of the machine characteristics and to accurately define the type of product most suitable for the application.

### 1) Calculate the load torque

This is the torque of the load and the friction of the mechanism, which the clutch has to overcome before rotation of the driven part is obtained. The value is basically equal to the tangential force exercised on a lever arm.

$$M_l = F \cdot R \cdot n_2 / n_1$$

where:

- $M_l$  = static source torque in Nm
- $F$  = force in N
- $R$  = radius in m
- $n_1$  = speed of the clutch or brake shaft in  $\text{min}^{-1}$
- $n_2$  = speed of the mechanism's shaft in  $\text{min}^{-1}$

### 2) Calculate the moment of inertia

The moment of inertia represents the mass to be brought to speed or to stop until synchronism between the drive shaft and driven shaft has been obtained. Consequently this is directly related to the inertia reflected on the clutch shaft. Rotational and linear inertia's are calculated utilizing following formulas:

## Rotational Inertia

### Solid cylinder

$$J = 1/2 \cdot m \cdot R^2$$

### Hollow cylinder

$$J = 1/2 \cdot m \cdot (R^2 + r^2)$$

where:

- $J$  = in  $\text{kgm}^2$
- $m$  = mass in kg
- $R$  = outer radius in m
- $r$  = inner radius in m

Next the total of the inertia's need to be referred to the shaft of the clutch as a function of the square of the speed ratios.

$$J_{\text{total}} = J_1 + J_2 \left( \frac{n_2}{n_1} \right)^2 + J_3 \left( \frac{n_3}{n_1} \right)^2$$

where:

- $J_{\text{total}}$  = Total inertia in  $\text{kgm}^2$
- $n_1$  = speed of drive shaft in  $\text{min}^{-1}$
- $n_2$  = speed of intermediate shaft in  $\text{min}^{-1}$
- $n_3$  = speed of driven shaft in  $\text{min}^{-1}$
- $J_1$  = inertia of drive shaft in  $\text{kgm}^2$
- $J_2$  = inertia of intermediate shaft in  $\text{kgm}^2$
- $J_3$  = inertia of driven shaft in  $\text{kgm}^2$

## Linear Inertia

$$J = 91 \cdot m \cdot v^2 / n^2$$

where:

- $J$  = inertia in  $\text{kgm}^2$
- $m$  = mass in kg
- $v$  = speed in m/s
- $n$  = rotational speed in  $\text{min}^{-1}$

# Clutches and Brakes Size and Selection

## Total Inertia

This is the sum of all rotational and reflected inertia's (including the inertia of the clutch or brake parts).

### 3) Time to accelerate or decelerate

$$M_d = (J_{total} \cdot n) / (9,55 \cdot t)$$

where:

$M_d$  = acceleration/deceleration torque in Nm

$J_{total}$  = total inertia in  $\text{kgm}^2$

$n$  = speed of clutch or brake shaft in  $\text{min}^{-1}$

$t$  = acceleration / deceleration time required in s

### 4) Time to accelerate or decelerate

$$M_{total} = M_d \pm M_i$$

(except lifting, for this kind of application, please contact us)

where :

$M_{total}$  = in Nm

$M_i$  = static torque in Nm

$M_d$  = acceleration/deceleration torque in Nm

The nominal clutch or brake's torque has to be always bigger than the torque calculated with this method.

### 5) acceleration or deceleration real time

$$t = (J_{total} \cdot n) / (9,55 \cdot (M_n \pm M_i))$$

where:

$t$  = in s

$J_{total}$  = total inertia in  $\text{kgm}^2$

$n$  = speed of clutch or brake shaft in  $\text{min}^{-1}$

$M_n$  = nominal torque of the chosen clutch or brake ..... in Nm

$M_i$  = static torque in Nm (- for a clutch, + for a brake)

## Energizing Modes

The Warner Electric product line of clutches and brakes contains devices energized:

- Electromagnetically
- Hydraulically
- Pneumatically
- Mechanically

They can be activated by:

- Applying power or pressure; = the friction surfaces are compressed when the force is applied.
- Absence of power or pressure; = the friction surfaces are compressed by spring force which makes these products suitable for use as security devices.

The choice is also determined by the time of use in the rotating or stop position.

## Engagement

When a speed difference between the drive and the driven axis is present, only the use of single or multi-disc clutches or brakes is permitted. With zero speed difference or engagement at standstill, the use of a tooth clutch or brake becomes possible.

Usually toothed devices have smaller diameters  $D$  than disc devices of the same ratings. Also they are normally activated by applying power. To establish the torque rating of a tooth device one should understand that

under no condition can they withstand loads higher than specified in their data tables. (contrary to a friction clutch, the tooth clutch can never slip). Therefore one must know:

- The maximum peak torque produced by the drive system (watch out for accel/decelerations and inertia functions).
- The presence of shock and vibration in the drive system

Since in many cases it is difficult to know these elements, for devices engaged by power on, a safety factor  $K = 3$  should be applied. For lifting motion, use of a tooth device is forbidden. For friction based devices, the torque ratings listed in our tables are based on "run in" conditions. In new conditions the transmissible torque may be below 50% of their nominal value. Nominal ratings are obtained after several operations with a differential speed above 1m/s. In order to obtain a high positioning precision and rapid acceleration a "run in" operation before use is recommended. In such applications the use of a Warner Electric power supply with boost current will help to reduce the engage and disengage times.

## Operating Conditions

Lubricated - For applications with high energy per cycle, we recommend the use of a multi disc device in lubricated environment. This will keep the surface wear low and particularly the lifetime of the friction surface will be increased. The lubricant used should have a viscosity below 40 centistokes at 50°C without a high-pressure additive. If possible do not submerge the devices.

Dry - Recommended operation temperature -25°C to +40°C. The functional friction materials used in dry environments, generally steel/organic combinations, have a higher friction factor than those used in lubricated environments. This results in a higher level of wear as a function of the energy per cycle. As a consequence it is important to correctly select the product as a function of the operation parameters and heat dissipation capacity. Underrating will result in higher wear as well as deformation of the friction materials.

Mixed - For use in mixed environments a protection against grease and dirt particles should be taken into account.

## Heat Dissipation

During clutching or braking, the mechanical energy is through friction transformed into heat. This lost energy needs to be absorbed by the clutch or brake without causing damage. In addition it affects its lifetime. Use the following formulae to calculate the heat dissipation:

### Clutch or Brake

$$W = (J_{total} \cdot n^2 / 182,5) \cdot (M_n / (M_n \pm M_i))$$

where:

$W$  = Work in Joules

$J_{total}$  = Total inertia in  $\text{kgm}^2$

$M_n$  = nominal torque of the chosen clutch or brake .... in Nm

# Clutches and Brakes Sizing and Selection

- $M_s$  = static torque for clutch in Nm
- +  $M_b$  = static torque for brake in Nm
- $n$  = clutch or brake speed in  $\text{min}^{-1}$

For vertical motion from top to bottom + and - are reversed

## Torque limiter

$$W = M_d \cdot n \cdot t / 9,55$$

where:

- $W$  = in Joules
- $M_d$  = slip torque in Nm
- $n$  = speed in  $\text{min}^{-1}$
- $t$  = slipping time in seconds

**Using the results obtained, verify the heat dissipation using the diagrams shown with each product to see if the product selected meets this requirement.**

## Mounting Position

In this catalogue each product has been clearly identified for horizontal or vertical use. In some cases devices specified for horizontal use may be used in vertical position. Please consult factory for more information.

## Power Supply

**Electric** - Our electric clutches & brakes operate with DC or rectified AC voltage. The standard voltages are 24, 103.5 and 207 Volts. Warner Electric offers power supplies to convert the AC voltage and to maintain a DC switching ensuring short response times.

All power supplies meet the applicable CE standards. Switching is possible on the AC or the DC side, however, switching on the AC side is 5 to 6 times slower than DC side switching.

Certain electro release devices apply a bi-voltage, the high voltage is used during the actual engagement, while the low voltage is used to hold the armature in position. Typical voltage combinations are 103.5/48 or 207/103.5 VDC.

**Back EMF** - When de-energizing the coil an important back EMF voltage is produced, particularly for higher torque rated models. This voltage may even damage components in the control circuit. We recommend that these peak voltages are suppressed by connecting a capacitor across the coil. (This protection is included in our power supplies).

Again do not hesitate to consult the factory for further information.

**Pneumatic** - The normal service pressure for Warner Electric clutches and brakes varies between 5 and 6 bars.

For devices activated by pressure, the transmissible torque is directly proportional to the pressure applied. We recommend the use of a filter/regulator and an air lubricator to prevent all risks of corrosion of the

air chamber. To avoid pressure losses in axial supplies the use of an air tight connection between the hub and the shaft is recommended. For radial supplies, a flexible connection without constraints is recommended.

**Hydraulic** - The normal service pressure for Warner Electric clutches and brakes is listed in the product tables. Different service pressures meeting your operating conditions can be used. In order to protect the gliding surfaces of the piston/cylinder the use of filtered hydraulic oil with 10 micron grade and a viscosity suitable to the operating conditions, is recommended. For the friction surfaces, use of an oil with a viscosity up to ISO VG46 and compatible for use with sintered bronze is recommended.

## Units

### Electricity

Capacity	F	Resistance	$\Omega$
Current	A	Voltage	V
Inductance	H	Pressure	bar

### Mechanical

Acceleration	$\text{m/s}^2$	Power	W
Angle	$^\circ$	Temperature	$^\circ\text{C}$
Torque	Nm	Time	s
Force	N	Energy	J
Gravity	$\text{m/s}^2$	Angular Speed	rd/s
Length	m	Linear Speed	$\text{m/s}$
Mass	kg	Rotational Speed	$\text{min}^{-1}$
Voluminal Mass	$\text{kg/m}^3$		
Inertia	$\text{kgm}^2$		

## Material Density

acrylic	1.2	iron	7.9
aluminum	2.7	iron (cast)	7.3
bakelite	1.3	magnesium	1.7
brass	8.5	nickle	8.8
bronze	8.9	rubber	1.2
copper	8.9	steel	7.8
glass	2.6	teflon	2.2

## Conversions

Length	inch	feet	yard	mm	m	km
	1	0.08333	0.02778	25.4	0.0254	-
	12	1	0.3333	304.8	0.3048	-
	36	3	1	914.4	0.9144	-
	0.03937	$3281 \times 10^{-6}$	$1094 \times 10^{-6}$	1	0.001	$10^{-6}$
	39.37	3.281	1.094	1000	1	0.001
	39370	3281	1094	106	1000	1
Mass	dram	oz	lb	g	kg	Mg
	1	0.0625	0.003906	1.772	0.001772	$1.772 \times 10^{-6}$
	16	1	0.0625	28.35	0.02835	$28.35 \times 10^{-6}$
	256	16	1	453.6	0.4536	$453.6 \times 10^{-6}$
	0.5644	0.03527	0.002205	1	0.001	$10^{-6}$
	564.4	35.27	2.205	1000	1	0.0001
	$564.4 \times 10^3$	35270	2205	$10^6$	1000	1
Force	dram	oz	lb	N	kN	
	1	0.0625	0.003906	0.0173656	$17.3 \times 10^{-6}$	
	16	1	0.0625	0.27783	$277.83 \times 10^{-6}$	
	256	16	1	4.44528	$4445.28 \times 10^{-6}$	
	57.592	3.59898	0.225	1	0.0001	
	$57.592 \times 10^3$	3598.9896	225	1000	1	
Torque	oz.in	lb.in	lb.ft	Ncm	Nm	
	1	0.0625	0.005208	0.706	0.00706	
	16	1	0.0833	11.3	0.113	
	192	12	1	135.6	1.356	
	1.4162	0.0885	0.0074	1	0.01	
	141.619	2 8.8512	0.7376	100	1	
Inertia	oz.in <sup>2</sup>	lb.in <sup>2</sup>	lb.ft <sup>2</sup>	kgcm <sup>2</sup>	kgm <sup>2</sup>	
	1	0.0625	0.000434	0.183	$18.3 \times 10^{-6}$	
	16	1	0.006944	2.926	$0.2926 \times 10^{-3}$	
	2304	144	1	421.344	0.421344	
	5.465	0.34156	$2.3718 \times 10^{-3}$	1	0.0001	
	54650	3415.6	23.718	10000	1	
Power	HP	kp m/s	Nm/s=J/s=W	kW	kcal/s	BTU/s
	1	76.04	745.7	0.7457	0.1782	0.7073
	$13.15 \times 10^{-3}$	1	9.807	$9.807 \times 10^{-3}$	$2.344 \times 10^{-3}$	$9.301 \times 10^{-3}$
	$1.341 \times 10^{-3}$	0.102	1	10-3	$239 \times 10^{-6}$	$948.4 \times 10^{-6}$
	1.341	102	1000	1	0.239	0-Jan
	5.614	426.9	4187	4.187	1	3.968
	1.415	107.6	105	1.055	0.252	1

## Electro-Magnetic Single Disc Clutch

### Characteristics

- Electrically operated 12, 24, 103,5 VDC
- Single friction face
- Activated by power on

### Utilisation

- Coupling of a pulley or a shaft

### Particularities

- No backlash
- For dry use
- No residual torque in disengaged position
- Fixed OM inductor

### Adjustments

- Airgap "P" should be adjusted at installation
- Requires wear compensation

### Maintenance Manual

- SM 304

### Mounting Precautions

- Centre the inductor
- Observe dimension "M"
- Device intended for horizontal or vertical use

### Power Supply

- For 24 volts versions only :  
 CBC 400-24 - CBC 450-24  
 CBC 500-24 - CBC 550-24  
 CBC 700 (overexcitation)  
 CBC 140-5 + CBC 140-T (24V)  
 CBC 140-5 (103,5V)

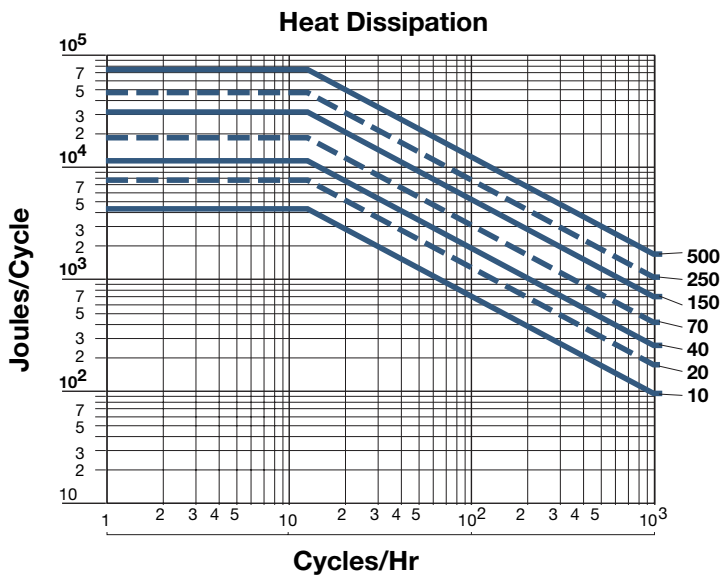

## Electro-Magnetic Single Disc Clutch

**EUROstandard  
Indirect Drive**

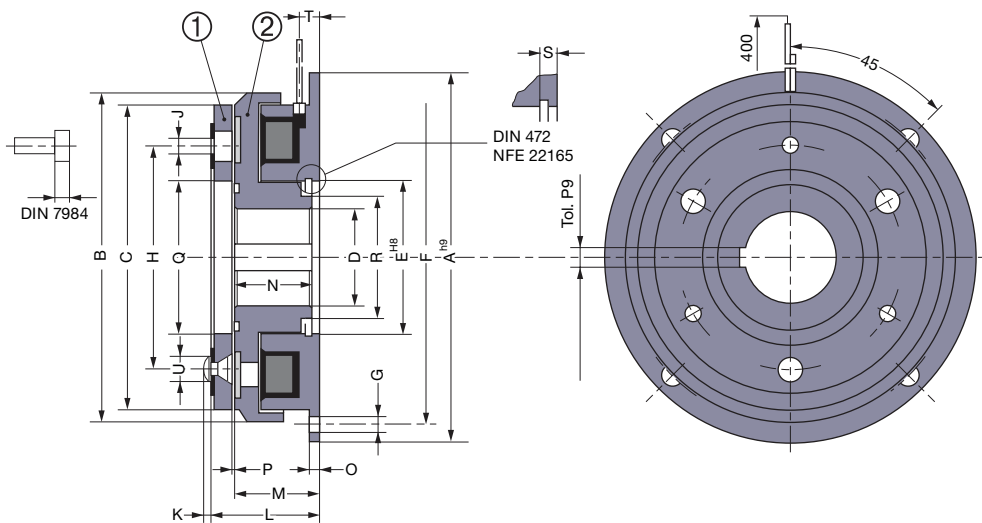

Sizes		10	20	40	70	150	250	500
<b>Nom. Torque</b>	[Nm]	7	15	30	60	120	250	500
<b>Max. Speed</b>	[min <sup>-1</sup> ]	8000	6000	5000	4000	3000	3000	2000
<b>Power</b>	P20[U=12/24/103,5V] [W]	12,5	17	27	31	44	59	83
	A	80	100	125	150	190	230	290
	B	68	86	107	134	170	213	267
	C	63	80	100	125	160	200	250
	D min	10H8	10H8	14H8	14H7	20H7	25H7	25H7
	D Std	10/15/17	10/17/20	20/25/30	25/30/35	30/40/45	40/50/60	50/60/80
	D max	17H8	22H8	30H8	40H7	50H7	65H7	80H7
	E	35	42	52	62	80	100	125
	F	72	90	112	137	175	215	270
	G For screw	4xM4	4xM5	4xM6	4xM6	4xM8	4xM8	4xM10
	H	46	60	76	95	120	158	210
	J (1) For screw	3xM3	3xM4	3xM5	3xM6	3xM8	3xM10	4xM12
	K	1,5	1,5	2,5	3	3	3	5
	L	28	31	36	40,5	46,5	55,5	64
	M	24	26,5	30	33,5	37,5	44	51
	N	22	24	27	30	34	40	47
	O	2	2,5	3	3,5	4	5	6
	P	0,2	0,2	0,2	0,3	0,3	0,5	0,5
	Q	35	41	52	62	80	100	125
	R	23	28,5	40	45	64	77	100
	S	3,5	4,3	5	5,5	6	7	8
	T	5,6	6,5	9	9,5	11	10	12
	U	6	6	10	12	12	17	20
<b>Inertia</b>	① [kgm <sup>2</sup> ]	0,00004	0,00012	0,0005	0,0013	0,0049	0,0140	0,0360
<b>Inertia</b>	② [kgm <sup>2</sup> ]	0,00011	0,00027	0,0008	0,0022	0,0065	0,0195	0,0550
<b>Weight</b>	[kg]	0,5	0,9	1,7	3	5,5	10	18,5
<b>Connection</b>		<b>Leads</b>			<b>Cable</b>			

### Connector Options

(Delivered without cable)

2 poles, capacity : 0,5/2,5mm<sup>2</sup>



Keyway according to ISO R773 / BS 4235 / DIN 6885-1 / NFE 22-175, tolerance P9 (1) Armature, Fixing "J" by screws DIN7984 (not provided)

# SFM VAR 10

## Electro-Magnetic Single Disc Clutch

### Characteristics

- Electrically operated 12, 24, 103,5 VDC
- Single friction face
- Activated by power on

### Utilisation

- Coupling of a pulley or a shaft

### Particularities

- No backlash
- For dry use
- No residual torque in disengaged position
- Fixed inductor mounted on ball bearings

### Adjustments

- Airgap "P" should be adjusted at installation
- Requires wear compensation

### Maintenance Manual

- SM 304

### Mounting Precautions

- The anti-rotation device of the electromagnet shall be inserted in anti rotation slot, with a side play of 0,5 mm and a 1 mm play to the bottom. This avoids a normal stress on the ball-bearings.
- We strongly recommend to mount a damping elastic slot in the anti-rotation device in case of vibrations
- Device intended for horizontal or vertical use

### Power Supply

- For 24 volts versions only :  
CBC 400-24 - CBC 450-24  
CBC 500-24 - CBC 550-24  
CBC 700 (overexcitation)  
CBC 140-5 + CBC 140-T (24V)  
CBC 140-5 (103,5V)

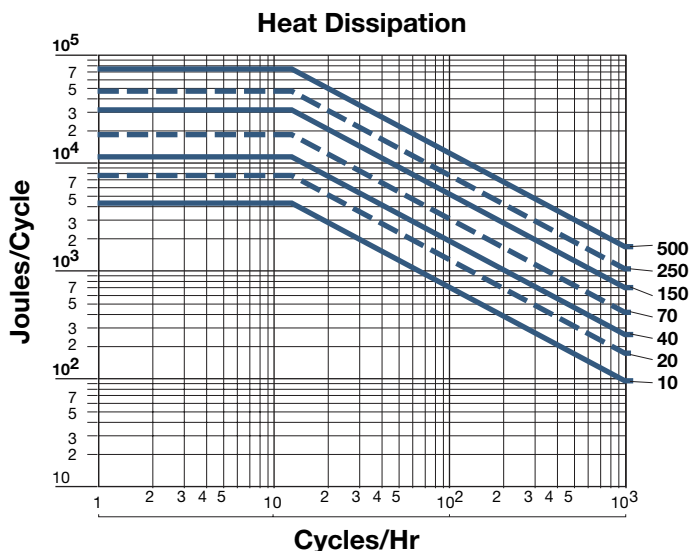



## Electro-Magnetic Single Disc Clutch

Sizes  
150 - 500

10 - 70

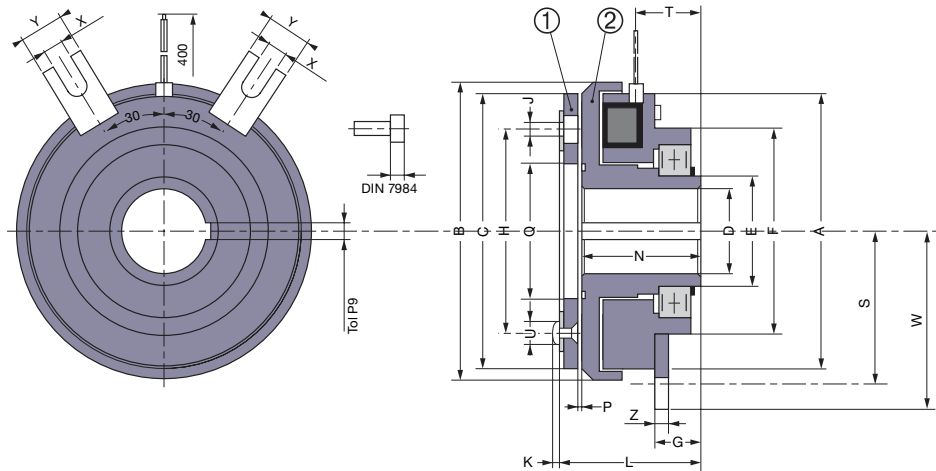

**EUROstandard  
Indirect Drive  
Bearing Mounted**

Sizes		10	20	40	70	150	250	500
<b>Nom. Torque</b>	[Nm]	7	15	30	60	120	250	500
<b>Max. Speed</b>	[min <sup>-1</sup> ]	8000	6000	5000	4000	3000	2500	2000
<b>Power</b>	P20[U=12/24/103,5V] [W]	12,5	17	27	31	44	59	83
A		65,5	84	100	125	160	200	250
B		68	86	107	134	170	213	267
C		63	80	100	125	160	200	250
D* min		10H8	10H8	14H8	14H7	20H7	25H7	25H7
D* Std		10/15/17	10/17/20	20/25/30	25/30/35	30/40/45	40/50/60	40/50/60
D* max		17H8	22H8	30H8	40H7	50H7	65H7	65H7
E		30	35	45	55	70	85	85
F		64	68	85	100	127	152	152
G		3	17	19	21,5	24	30	30
H		46	60	76	95	120	158	210
J (1) For screw		3xM3	3xM4	3xM5	3xM6	3xM8	3xM10	4xM12
K		1,5	1,5	2,5	3	3	3	5
L		44	48	55	62	70,5	85,5	94
N		40	43,5	49	55	61,5	74	81
P		0,2	0,2	0,3	0,3	0,3	0,5	0,5
Q		35	41	52	62	80	100	125
S		36	45	56	71	88	107,5	135
T		22,5	27	28	31	35	40	42
U		6	6	10	12	12	17	20
W		41	50	60	77,5	99	118,5	146
X		4,1	4,1	4,1	5,5	11	11	11
Y		12	12	12	20	22	22	22
Z		1,5	1,5	2	2	4	4	4
<b>Inertia</b>	① [kgm <sup>2</sup> ]	0,00004	0,00012	0,0005	0,0013	0,0049	0,0140	0,0360
<b>Inertia</b>	② [kgm <sup>2</sup> ]	0,00011	0,00029	0,0013	0,0024	0,0070	0,0206	0,0563
<b>Weight</b>	[kg]	0,7	1,2	2,3	4,0	7,6	13,0	22,2
<b>Connection</b>		<b>Leads</b>			<b>Cable</b>			

### Connector Options

(Delivered without cable)

2 poles, capacity : 0,5/2,5mm<sup>2</sup>



Keyway according to ISO R773 / BS 4235 / DIN 6885-1 / NF E 22-175, tolerance P9 (1) Armature, Fixing "J" by screws DIN7984 (not provided)

# SFM VAR 01

## Electro-Magnetic Single Disc Clutch

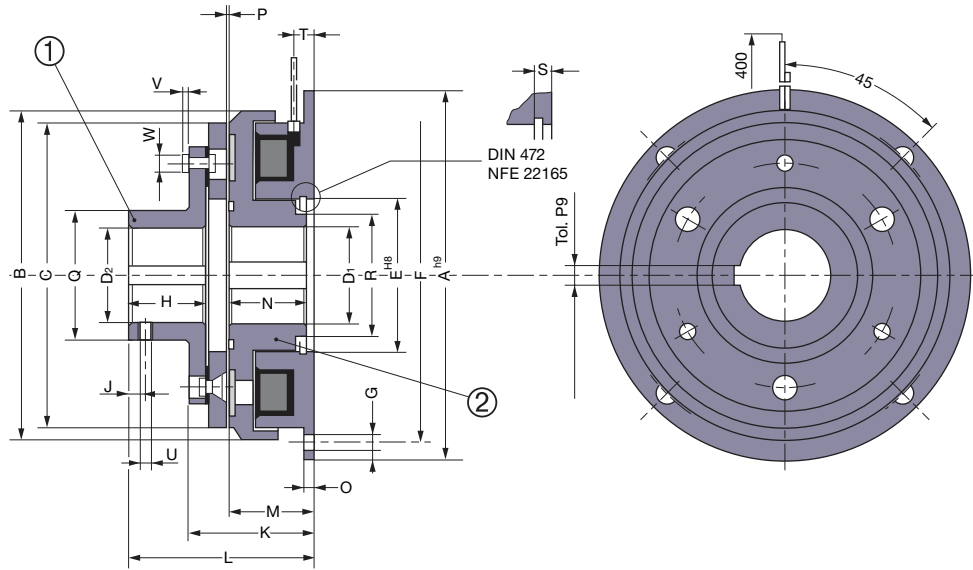

**EUROstandard  
Direct Drive**

Sizes		10	20	40	70	150	250	500
<b>Nom. Torque</b>	[Nm]	7	15	30	60	120	250	500
<b>Max. Speed</b>	[min <sup>-1</sup> ]	8000	6000	5000	4000	3000	2500	2000
<b>Power</b>	P20[U=12/24/103,5V] [W]	12,5	17	27	31	44	59	83
A		80	100	125	150	190	230	290
B		68	86	107	134	170	213	267
C		63	80	100	125	160	200	250
D1 min		10H8	10H8	14H8	14H7	20H7	25H7	25H7
D1 Std		10/15/17	10/17/20	20/25/30	25/30/35	30/40/45	40/50/60	50/60/80
D1 max		17H8	22H8	30H8	40H7	50H7	65H7	80H7
D2 min		10H8	10H8	14H8	14H7	20H7	25H7	25H7
D2 Std		10/15/17	10/17/20	20/25/30	25/30/35	30/40/45	40/50/60	50/60/80
D2 max		17H8	20H8	30H8	35H7	45H7	60H7	80H7
E		35	42	52	62	80	100	125
F		72	90	112	137	175	215	270
G For screw		4xM4	4xM5	4xM6	4xM6	4xM8	4xM8	4xM10
H		15	20	25	30	38	48	55
J		5	6	6	10	10	15	20
K		31,5	35	41	46,5	53,5	66,3	78,3
L		43	51	61	70,5	84,5	103,5	119,5
M		24	26,5	30	33,5	37,5	44	51
N		22	24	27	30	34	40	47
O		2	2,5	3	3,5	4	5	6
P		0,2	0,2	0,3	0,3	0,3	0,5	0,5
Q		27	32	42	49	65	83	105
R		23	28,5	40	45	64	77	100
S		3,5	4,3	5	5,5	6	7	8
T		6,5	6,5	9	9,5	11	10	12
U		M4	M4	M4	M6	M8	M10	M10
V		1,5	2	2,5	3	4	1,5	2,5
W		6	8	10	12	16	20	24
<b>Inertia</b>	① [kgm <sup>2</sup> ]	0,00006	0,00021	0,00079	0,0020	0,0077	0,0242	0,0705
<b>Inertia</b>	② [kgm <sup>2</sup> ]	0,00011	0,00027	0,0008	0,0022	0,0065	0,0195	0,0550
<b>Weight</b>	[kg]	0,59	1,1	2,07	3,6	6,9	13,1	24,5
<b>Connection</b>		<b>Leads</b>			<b>Cable</b>			

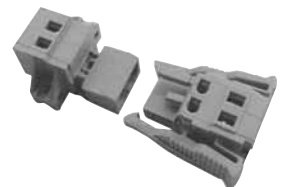

**Connector Options**  
(Delivered without cable) 2 poles, capacity : 0,5/2,5mm<sup>2</sup>

Keyways according to ISO R773 / BS 4235 / DIN 6885-1 / NF E 22-175, tolerance P9

## Electro-Magnetic Single Disc Clutch

Size  
150-500

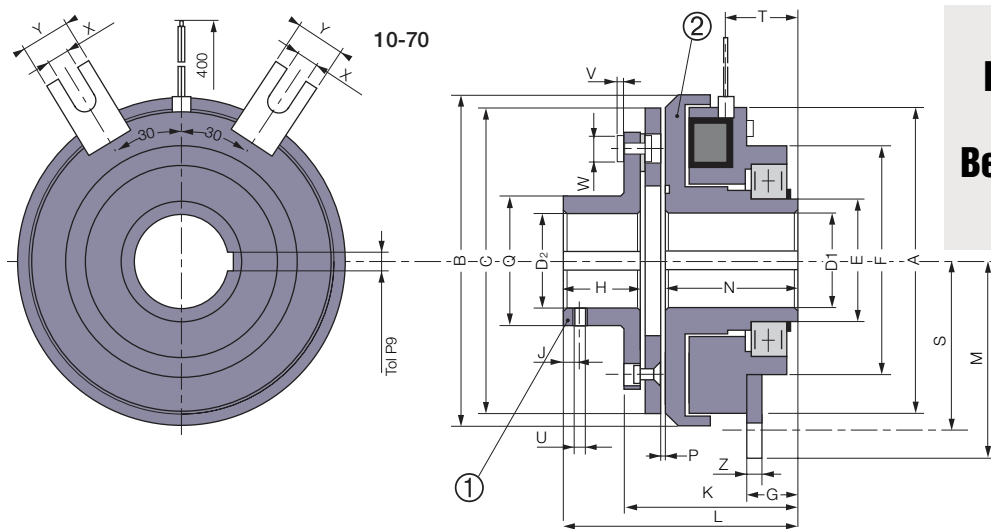

**EUROstandard  
Direct Drive  
Bearing Mounted**

Sizes		10	20	40	70	150	250	500	
<b>Nom. Torque</b>	[Nm]	7	15	30	60	120	250	500	
<b>Max. Speed</b>	[min <sup>-1</sup> ]	8000	6000	5000	4000	3000	2500	2000	
<b>Power</b>	P20[U=12/24/103,5V] [W]	12,5	17	27	31	44	59	83	
A		64	81	100	125	160	200	250	
B		68	86	107	134	170	213	267	
C		63	80	100	125	160	200	250	
D1* min		10H8	10H8	14H8	14H7	20H7	25H7	25H7	
D1* Std		10/15/17	10/17/20	20/25/30	25/30/35	30/40/45	40/50/60	40/50/60	
D1* max		17H8	22H8	30H8	40H7	50H7	65H7	65H7	
D2 min		10H8	10H8	14H8	14H7	20H7	25H7	25H7	
D2 Std		10/15/17	10/17/20	20/25/30	25/30/35	30/40/45	40/50/60	50/60/80	
D2 max		17H8	20H8	30H8	35H7	45H7	60H7	80H7	
E		30	35	45	55	70	85	85	
F		64	68	85	100	127	152	152	
G		3	17	19	21,5	24	30	30	
H		15	20	25	30	38	48	55	
J		5	6	6	10	10	15	20	
K		47,5	52	60	68	77,5	93,3	108,5	
L		59	68	80	92	108,5	133,5	149,5	
M		41	50	60	77,5	99	118,5	146	
N		40	43,5	49	55	61,5	74	81	
P		0,2	0,2	0,3	0,3	0,3	0,5	0,5	
Q		27	32	42	49	65	83	105	
S		36	45	56	71	88	107,5	135	
T		22,5	26,8	28	31	35	40	42	
U		M4	M4	M4	M6	M8	M10	M10	
V		1,5	2	2,5	3	4	1,5	2,5	
W		6	8	10	12	16	20	24	
X		4,1	4,1	4,1	5,5	11	11	11	
Y		12	12	12	20	22	22	22	
Z		1,5	1,5	2	2	4	4	4	
<b>Inertia</b>	① [kgm <sup>2</sup> ]	0,00006	0,00021	0,00079	0,0020	0,0077	0,0242	0,0705	
<b>Inertia</b>	② [kgm <sup>2</sup> ]	0,00011	0,00029	0,0013	0,0024	0,0070	0,0206	0,0563	
<b>Weight</b>	[kg]	0,79	1,4	2,67	4,6	9	16,1	28,2	
<b>Connection</b>		<b>Leads</b>				<b>Cable</b>			

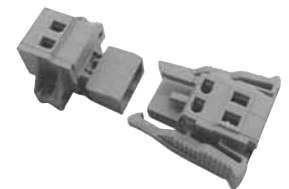

**Connector Options**  
(Delivered without cable) 2 poles, capacity : 0,5/2,5mm<sup>2</sup>

Keyways according to ISO R773 / BS 4235 / DIN 6885-1 / NF E 22-175, tolerance P9  
\* Mandatory delivered with finished bores

# E210 VAR 00

## Electro-Magnetic Single Disc Clutch

### Characteristics

- Electrically operated 24 or 103,5 VDC depending size
- Single friction face
- Activated by power on

### Utilisation

- Coupling of two shafts in line

### Particularities

- No backlash
- For dry use
- No residual torque in disengaged position
- Fixed inductor mounted on ball bearings

### Adjustments

- Airgap "P" should be adjusted at installation
- Does not require wear compensation

### Maintenance Manual

- SM 307

### Mounting Precautions

- The anti-rotation device of the electromagnet shall be inserted in anti rotation slot, with a side play of 0,5 mm and a 1 mm play to the bottom. This avoids a normal stress on the ball-bearings.
- We strongly recommend to mount a damping elastic slot in the anti-rotation device in case of vibrations
- Device intended for horizontal use; for vertical use, please consult the factory

### Power Supply

- For sizes until 1600 :  
CBC 400-24 - CBC 450-24  
CBC 500-24 - CBC 550-24  
CBC 140-5 + CBC 140-T
- For size 3200:  
CBC 140-5

### Mounting Example

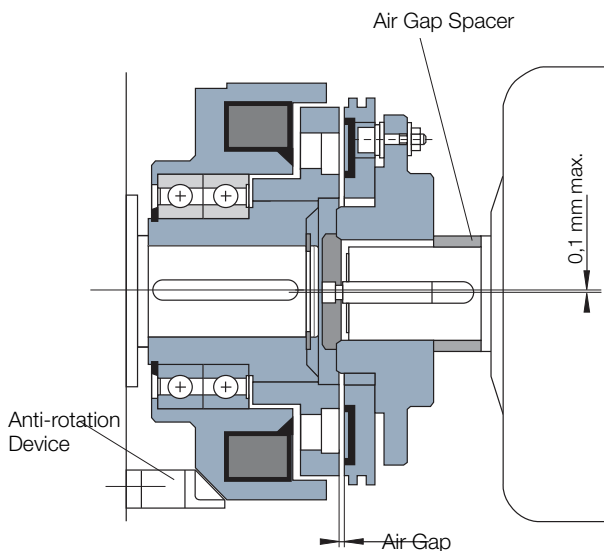

### Heat Dissipation

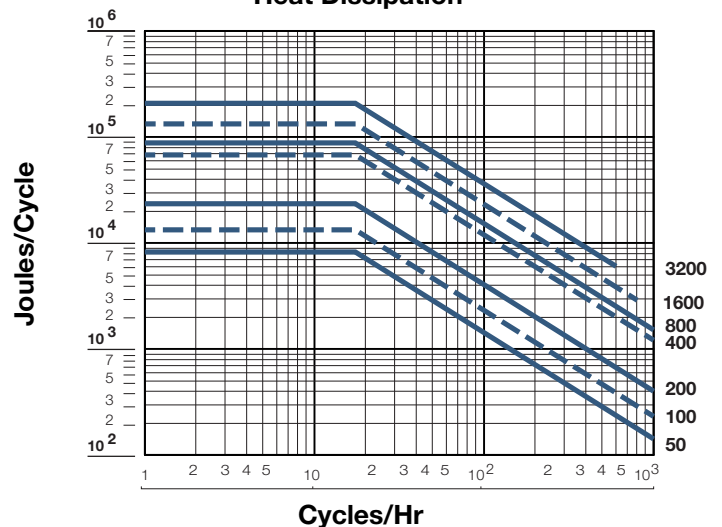

## Electro-Magnetic Single Disc Clutch

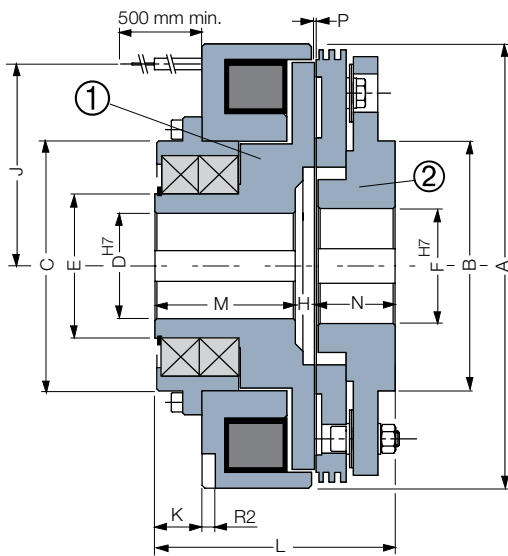

Size 50 - 200

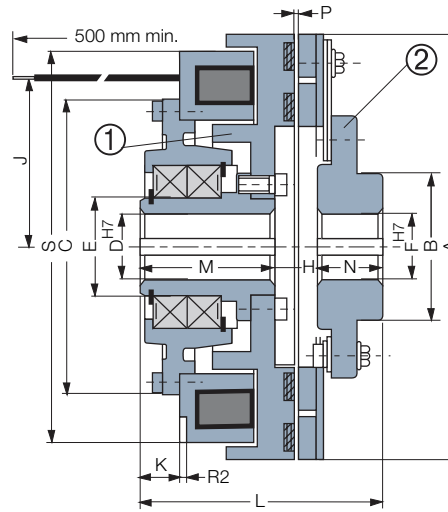

Size 400-3200

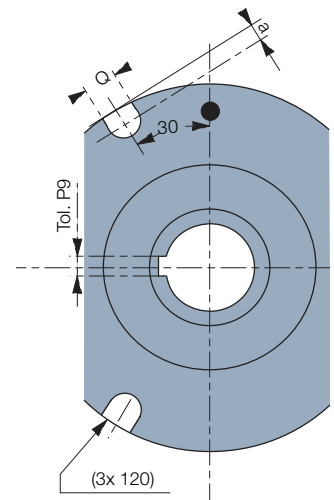

Sizes		50	100	200	400	800	1600	3200
<b>Nom. Torque</b>	[Nm]	50	100	200	400	800	1600	3200
<b>Max. Speed</b>	[min.]	4150	3200	2600	2000	1700	1500	1500
<b>Voltage</b>	[VDC]	24	24	24	24	24	24	103,5
<b>Power</b>	P20 [W]	52	60	81	37	47	94	187
	A	139	173	231	260	300	360	450
	B	85	100	130	100	120	140	175
	C	90	110	155	185	220	265	318
	D* min	22	25	30	35	40	50	65
	D* max	35	45	55	65	75	90	100
	E	50	65	75	80	90	110	130
	F min	22	25	30	35	40	50	65
	F max	40	50	60	70	80	100	110
	H	10	10	12	14	16	20	20
	J	18	23	105	116	133	160	197
	K	17,5	19	24,5	21	24	28	77
	L	95	110	125	135	155	180	280
	M	55	65	73	75	85	100	160
	N	30	35	40	46	54	60	100
	P	0,3	0,3	0,5	0,5	0,6	0,8	0,8
	Q	12	12	16	16	18	20	20
	R2	6	6	7	7	8	10	12
	a	-	-	10	10	10	12	15
	S	-	-	-	249	287	340	426
<b>Inertia</b>	① [kgm <sup>2</sup> ]	0,00270	0,0085	0,0234	0,0635	0,124	0,313	0,781
<b>Inertia</b>	② [kgm <sup>2</sup> ]	0,00335	0,0128	0,0370	0,0342	0,0736	0,2042	0,681
<b>Weight</b>	[kg]	5,7	10,4	20	20,8	34,5	59	130
<b>Connection</b>		<b>Cable</b>						

**Direct Drive**

### Connector Options

(Delivered without cable)

2 poles, capacity : 0,5/2,5mm<sup>2</sup>

Keyways according to

ISO R773 / BS 4235 / DIN 6885-1 / NF E 22-175, tolerance P9

\* Mandatory delivered with finished bore

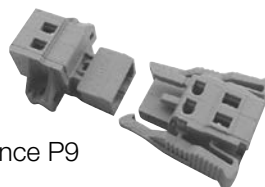

# E210 VAR 02

## Electro-Magnetic Single Disc Clutch

### Characteristics

- Electrically operated 24 or 103,5 VDC depending size
- Single friction face
- Activated by power on
- Expected ball bearing life 50 000 hours
- Accepts speeds of rotation superior to series E210 VAR 00

### Utilisation

- Coupling of two shafts in line
- From size 3200, we recommend to engage the clutch at a lower speed (about 300 min<sup>-1</sup>)

### Particularities

- No backlash
- For dry use
- No residual torque in disengaged position
- Fixed inductor mounted on ball bearings

### Adjustments

- Airgap "P" should be adjusted at installation
- Does not require wear compensation

### Maintenance Manual

- SM 307

### Mounting Precautions

- Device intended for horizontal or vertical use
- The anti-rotation device of the electromagnet shall be inserted in anti rotation slot, with a side play of 0,5 mm and a 1 mm play to the bottom. This avoids a normal stress on the ball-bearings.
- We strongly recommend to mount a damping elastic slot in the anti-rotation device in case of vibrations

### Power Supply

- For sizes until 1600 :  
CBC 400-24 - CBC 450-24  
CBC 500-24 - CBC 550-24  
CBC 140-5 + CBC 140-T
- For size 3200 and up: CBC 140-5

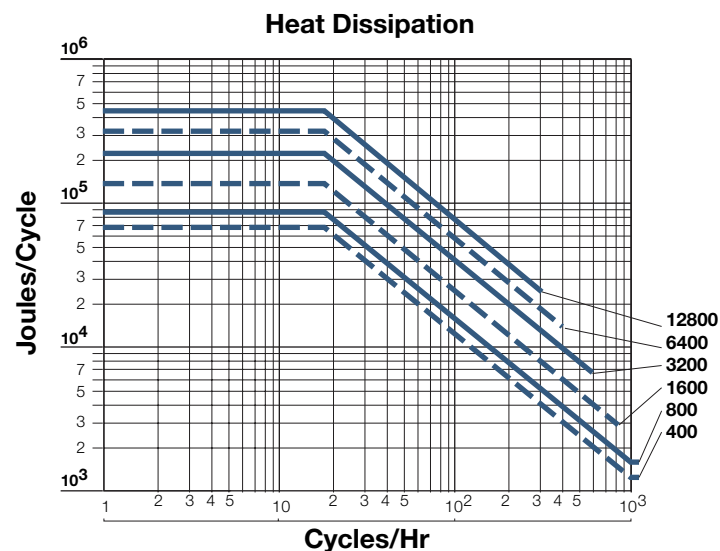

## Electro-Magnetic Single Disc Clutch

**Long Life  
High Speed  
Direct Drive**

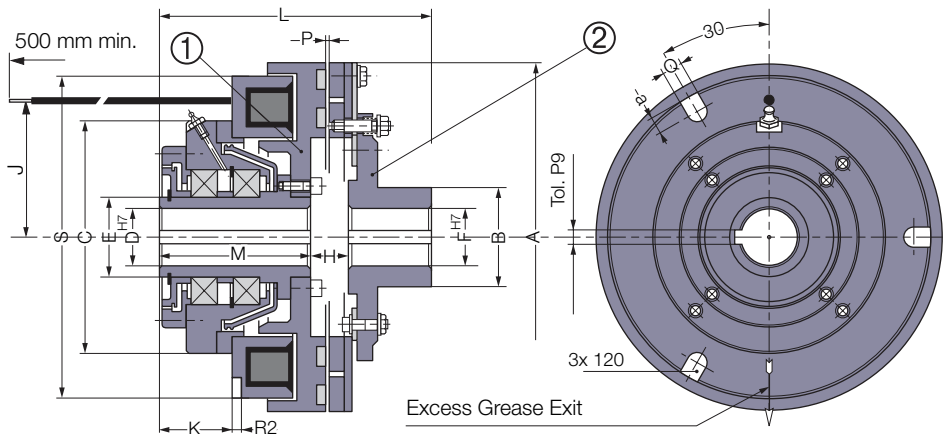

Sizes		400	800	1600	3200	6400	12800
<b>Nom. Torque</b>	[Nm]	400	800	1600	3200	6400	12800
<b>Max. Speed</b>	[min.⁻¹]	3000	2500	2200	1800	1500	1500
<b>Voltage</b>	[VDC]	24	24	24	103,5	103,5	103,5
<b>Power</b>	P20 [W]	37	47	94	187	264	336
	A	260	300	360	450	560	700
	B	100	120	140	175	230	255
	C	185	220	260	320	404	480
	D* min	35	40	50	65	85	100
	D* max	65	75	90	100	120	130
	E	80	90	110	130	160	180
	F min	35	40	50	65	80	100
	F max	70	80	100	110	150	170
	H	14	16	20	20	22	35
	J	116	133	160	197	248	310
	K	47	46	68	77	77	96
	L	161	177	220	280	315	390
	M	101	107	140	160	175	210
	N	46	54	60	100	118	145
	P	0,5	0,6	0,8	0,8	1	1
	Q	16	18	20	20	20	22
	R2	7	8	10	12	12	12
	a	10	10	12	15	15	18
	S	249	287	340	426	528	662
<b>Inertia</b>	① [kgm²]	0,0635	0,1280	0,3260	0,798	2,749	7,110
<b>Inertia</b>	② [kgm²]	0,0342	0,0736	0,2042	0,681	1,975	5,690
<b>Weight</b>	[kg]	25,5	35,2	61	132	238	400
<b>Connection</b>		<b>Cable</b>					

### Connector Options

(Delivered without cable)

2 poles, capacity : 0,5/2,5mm²

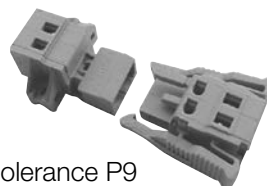

Keyways according to  
ISO R773 / BS 4235 / DIN 6885-1 / NF E 22-175, tolerance P9

\* Mandatory delivered with finished bores

# E220 VAR 00

## Electro-Magnetic Single Disc Clutch

### Characteristics

- Electrically operated 24 or 103,5 VDC depending size
- Single friction face
- Activated by power on

### Utilisation

- Coupling of a pulley or a hub

### Particularities

- No backlash
- For dry use
- No residual torque in disengaged position
- Fixed inductor mounted on ball bearings

### Adjustments

- Airgap "P" should be adjusted at installation
- Does not require wear compensation

### Maintenance Manual

- SM 307

### Mounting Precautions

- The anti-rotation device of the electromagnet shall be inserted in anti rotation slot, with a side play of 0,5 mm and a 1 mm play to the bottom. This avoids a normal stress on the ball-bearings.
- We strongly recommend to mount a damping elastic slot in the anti-rotation device in case of vibrations
- Device intended for horizontal use; for vertical use, please consult the factory

### Power Supply

- For sizes until 1600 :  
CBC 400-24 - CBC 450-24  
CBC 500-24 - CBC 550-24  
CBC 140-5 + CBC 140-T
- For size 3200:  
CBC 140-5

### Mounting Example

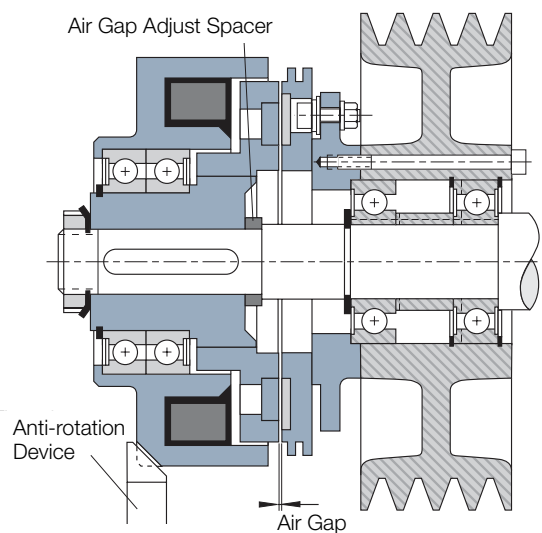

### Heat Dissipation

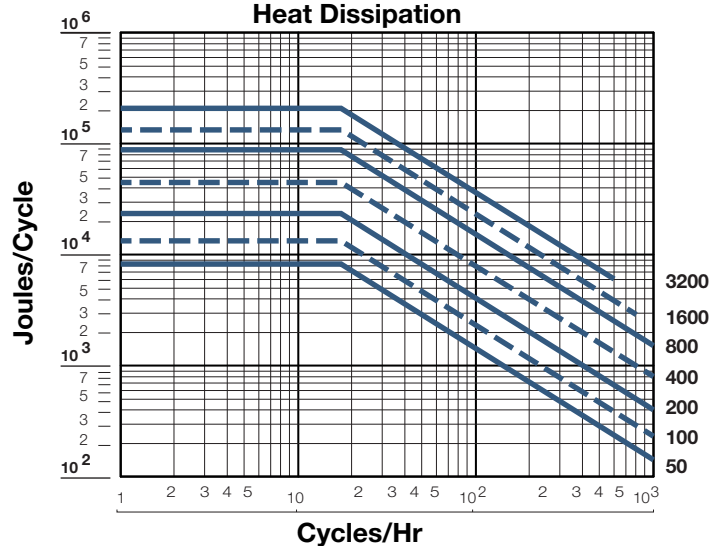



## Electro-Magnetic Single Disc Clutch

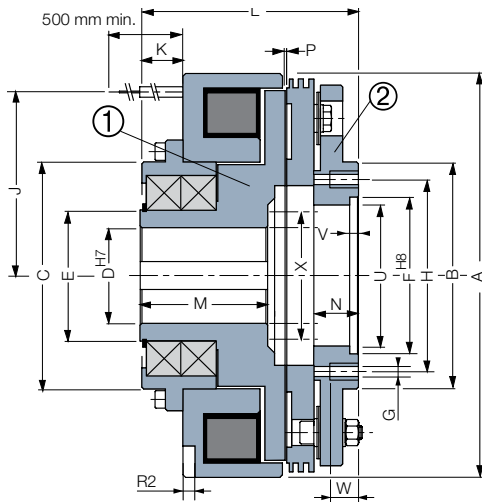

Size 50 - 200

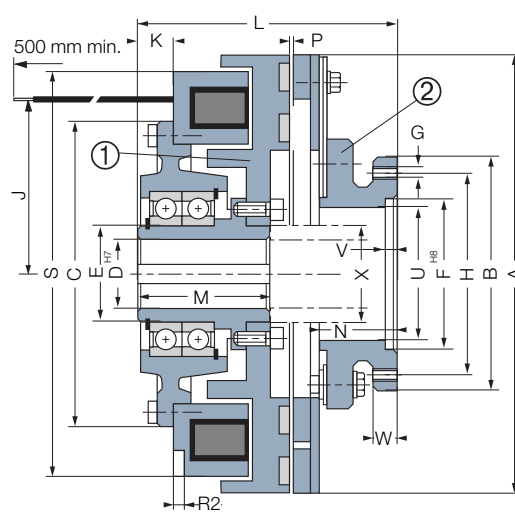

Size 400 - 3200

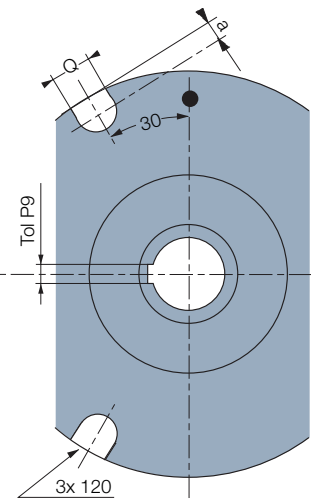

Sizes		50	100	200	400	800	1600	3200	
Nom. Torque	[Nm]	50	100	200	400	800	1600	3200	
Max. Speed	[min. <sup>-1</sup> ]	4150	3200	2600	2000	1700	1500	1500	
Voltage	[VDC]	24	24	24	24	24	24	103,5	
Power	P20	[W]	52	60	81	37	47	94	187
	A		139	173	231	260	300	360	450
	B		85	100	130	140	155	180	220
	C		90	110	155	185	220	265	318
	D* min		22	25	30	35	40	50	65
	D* max		35	45	55	65	75	90	100
	E		50	65	75	80	90	110	130
	F		62	75	90	100	115	140	150
	G		4xM6	6xM6	6xM8	6xM8	6xM10	8xM12	8xM12
	H		74	88	110	120	135	160	195
	J		18	23	105	116	133	160	197
	K		17,5	19	24,5	21	24	28	77
	L		95	110	12,5	135	155	180	250
	M		55	65	73	75	85	100	160
	N		18,5	21	25,5	41	49	55	60,4
	P		0,3	0,3	0,5	0,5	0,6	0,8	0,8
	Q		12	12	16	16	18	20	20
	R2		6	6	7	7	8	10	12
	a		-	-	10	10	10	12	15
	S		-	-	-	249	287	340	426
	U		55	68	81	90	106	126	135
	V		4	5	5	5	5	6	7
	W		12	12	16	14	15	18	20
Washer	X max		49	60	79	80	90	115	132
Inertia	①	[kgm <sup>2</sup> ]	0,00270	0,0085	0,0234	0,0635	0,124	0,313	0,781
Inertia	②	[kgm <sup>2</sup> ]	0,00335	0,0128	0,0370	0,0342	0,0736	0,2042	0,658
Weight		[kg]	5,7	10,4	20	20,8	34,5	59	120
Connection			<b>Cable</b>						

**Indirect Drive**

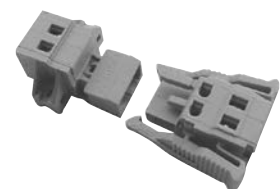

**Connector Options**  
(Delivered without cable)  
2 poles, capacity : 0,5/2,5mm<sup>2</sup>

Keyways according to  
ISO R773 / BS 4235 / DIN 6885-1 / NF E 22-175, tolerance P9  
\* Mandatory delivered with finished bores

# E220 VAR 02

## Electro-Magnetic Single Disc Clutch

### Characteristics

- Electrically operated 24 or 103,5 VDC, depending on size
- Single friction face
- Activated by power on
- Expected ball bearing life 50'000 hrs
- Accepts speeds of rotation superior to the series E220 VAR 00

### Utilisation

- Coupling of a pulley or a hub
- From size 3200, we recommend to engage the clutch at a lower speed (about 300 min<sup>-1</sup>)

### Particularities

- No backlash
- For dry use
- No residual torque in disengaged position
- Fixed inductor mounted on ball bearings

### Adjustments

- Airgap "P" should be adjusted at installation
- Does not require wear compensation

### Maintenance Manual

- SM 307

### Mounting Precautions

- Device intended for horizontal use
- The anti-rotation device of the electromagnet shall be inserted in anti rotation slot, with a side play of 0,5 mm and a 1 mm play to the bottom. This avoids a normal stress on the ball-bearings.
- We strongly recommend to mount a damping elastic slot in the anti-rotation device in case of vibrations

### Power Supply

- For sizes until 1600 :  
CBC 400-24 - CBC 450-24  
CBC 500-24 - CBC 550-24  
CBC 140-5 + CBC 140-T
- For size 3200 and up:  
CBC 140-5

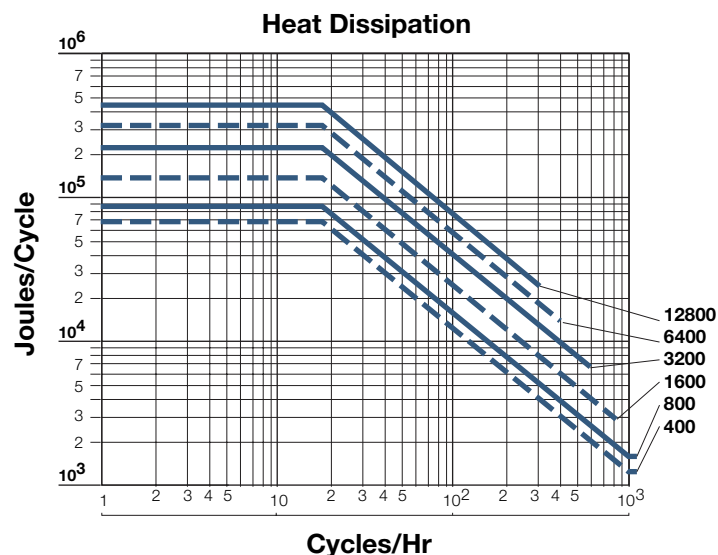

## Electro-Magnetic Single Disc Clutch

**Long Life  
High Speed  
Indirect Drive**

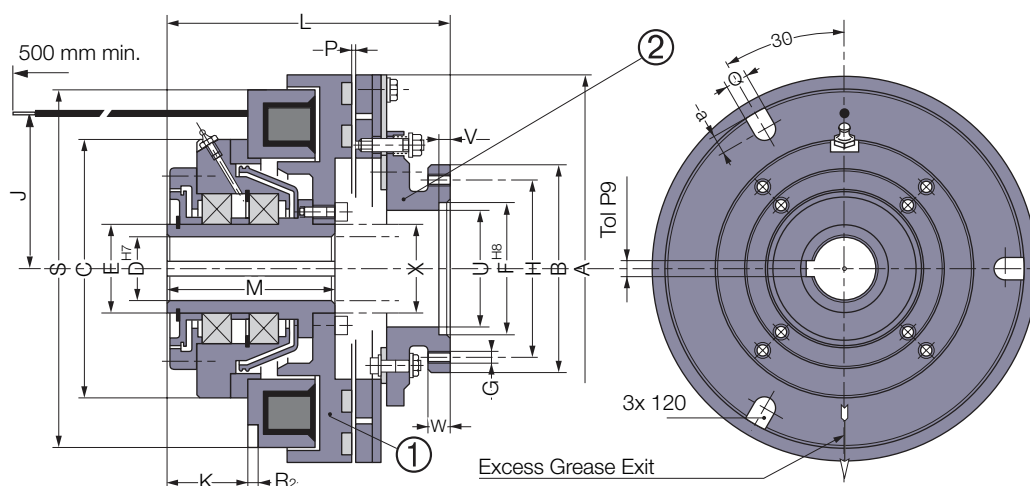

Sizes		400	800	1600	3200	6400	12800	
Nom. Torque	[Nm]	400	800	1600	3200	6400	12800	
Max. Speed	[min. <sup>-1</sup> ]	3000	2500	2200	1800	1500	1500	
Voltage	[VDC]	24	24	24	103,5	103,5	103,5	
Power	P20	[W]	37	47	94	187	336	
	A		260	300	360	450	560	700
	B		140	155	180	220	295	320
	C		185	220	260	320	404	480
	D* min		35	40	50	65	85	100
	D* max		65	75	90	100	120	130
	E		80	90	110	130	160	180
	F		100	115	140	150	180	215
	G		6xM8	6xM10	8xM12	8xM12	8xM16	12xM20
	H		120	135	160	195	260	280
	J		116	133	160	197	248	310
	K		47	46	68	77	77	96
	L		161	177	220	250	280	330
	M		101	107	140	160	175	210
	P		0,5	0,6	0,8	0,8	1	1
	Q		16	18	20	20	20	22
	R2		7	8	10	12	12	12
	a		10	10	12	15	15	18
	S		249	287	340	426	528	662
	U		90	106	126	135	160	197
	V		5	5	6	7	8	8
	W		14	15	18	20	25	28
Washer	X max		80	90	115	132	156	175
Inertia	①	[kgm <sup>2</sup> ]	0,0635	0,1280	0,3260	0,798	2,749	7,110
Inertia	②	[kgm <sup>2</sup> ]	0,0342	0,0736	0,2042	0,658	1,928	5,595
Weight		[kg]	25,5	35,2	61	122	220	380
Connection			Cable					

### Connector Options

(Delivered without cable)

2 poles, capacity : 0,5/2,5mm<sup>2</sup>

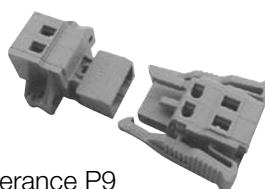

Keyways according to

ISO R773 / BS 4235 / DIN 6885-1 / NF E 22-175, tolerance P9

\* Mandatory delivered with finished bores

# E220 VAR 05

## Electro-Magnetic Single Disc Clutch

### Characteristics

- Electrically operated 24 or 103,5 VDC depending size
- Single friction face
- Activated by power on

### Utilisation

- Coupling of two shafts in line
- From size 3200, we recommend to engage the clutch at a lower speed (about 300 min<sup>-1</sup>)

### Particularities

- For dry use
- No residual torque in disengaged position
- Fixed inductor mounted on ball bearings
- Equipped with an elastic coupling

### Adjustments

- Does not require wear compensation

### Maintenance Manual

- SM 307

### Mounting Precautions

- The anti-rotation device of the electromagnet shall be inserted in anti rotation slot, with a side play of 0,5 mm and a 1 mm play to the bottom. This avoids a normal stress on the ball-bearings.
- We strongly recommend to mount a damping elastic slot in the anti-rotation device in case of vibrations
- Device intended for horizontal use, for vertical use please consult the factory

### Power Supply

- For sizes until 1600 :  
CBC 400-24 - CBC 450-24  
CBC 500-24 - CBC 550-24  
CBC 140-5 + CBC 140-T
- For size 3200 and up:  
CBC 140-5

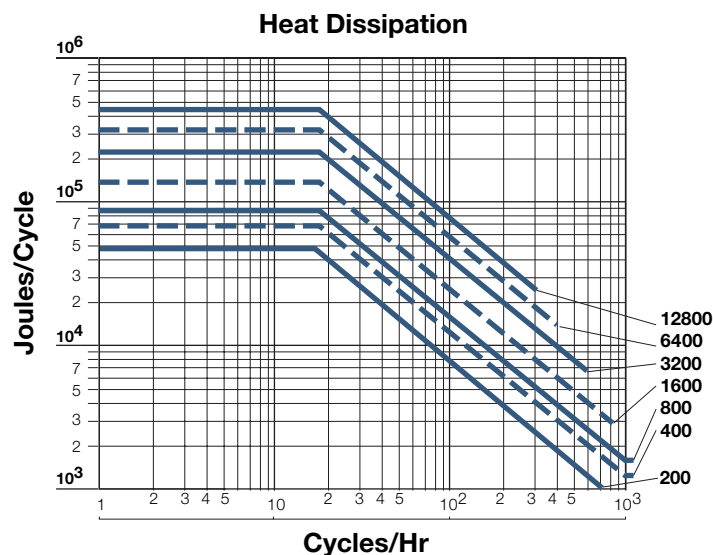

## Electro-Magnetic Single Disc Clutch

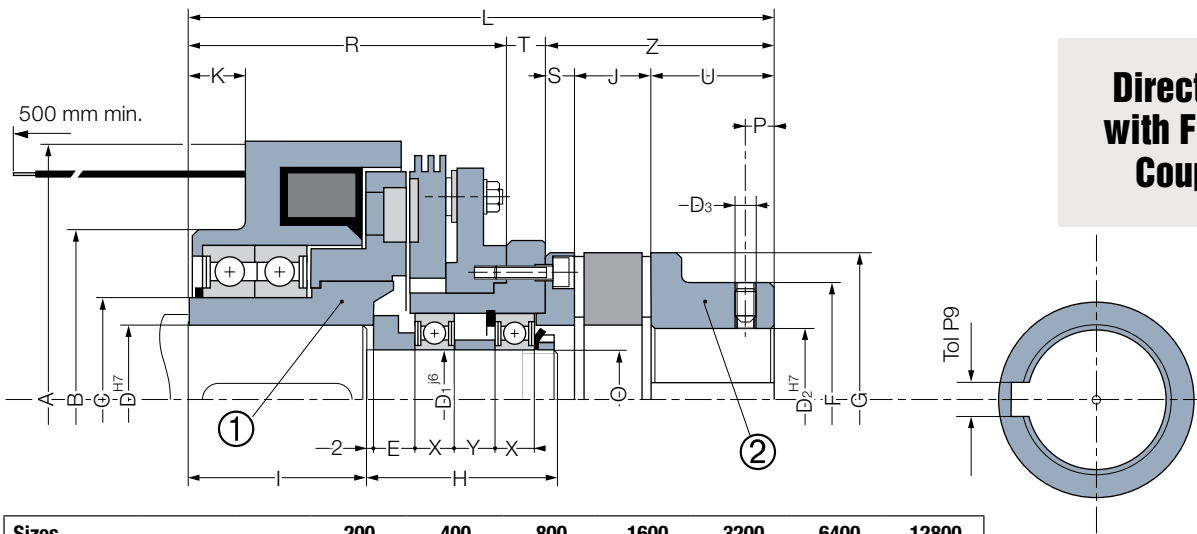

Sizes		200	400	800	1600	3200	6400	12800
<b>Coupling</b>		55	65	75	90	100	125	180
<b>Nom. Torque</b>	[Nm]	200	400	800	1600	3,200	6,400	12800
<b>Max. Speed</b>	[min.]	2600	2000	1700	1500	1500	1500	1500
<b>Voltage</b>	[VDC]	24	24	24	24	103,5	103,5	103,5
<b>Power</b>	P20 [W]	81	37	47	94	187	264	336
	A	231	260	300	360	450	560	700
	B	155	185	220	265	318	405	480
	C	75	80	90	110	130	160	180
	D* min	30	35	50	55	65	80	100
	D* max	55	65	75	90	100	120	130
	D1	30	35	50	55	60	80	90
	D2 min	20	22	30	40	50	60	85
	D2 max	55	65	75	90	115	145	200
	D3	M10	M10	M10	M12	M12	M12	M16
	E	18	20	15	26	21,5	25	30
	F	98	115	135	160	180	230	325
	G	120	135	160	200	225	290	420
	H	79	87	99	112	125	150	178
	I	71	73	83	98	158	173	208
	J	30	35	40	45	50	60	85
	K	24,5	21	24	28	77	77	96
	L	250	275	315	365	455	540	685
	O	M30X1,5	M35X1,5	M50X1,5	M55X2	M60X2	M80X2	M90X2
	P	20	20	20	30	30	30	40
	R	125	135	155	180	250	280	330
	S	13	14	16	19	21	28	39
	T	17	16	19	21	24	32	36
	U	65	75	85	100	110	140	195
	X	16	17	20	21	22	26	30
	Y	16	19	28	28	43	53	59
	Z	108	124	141	164	181	228	319
<b>Inertia</b>	① [kgm <sup>2</sup> ]	0,0234	0,0635	0,0124	0,313	0,781	2,749	7,110
<b>Inertia</b>	② [kgm <sup>2</sup> ]	0,0521	0,0584	0,12	0,333	0,901	2,775	10,080
<b>Weight</b>	[kg]	27,7	31,5	50,5	85,5	158	298	597
<b>Connection</b>	<b>Cable</b>							

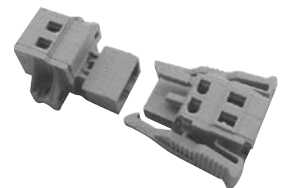

**Connector Options**  
 (Delivered without cable)  
 2 poles, capacity :  
 0,5/2,5mm<sup>2</sup>

Keyways according to  
 ISO R773 / BS 4235 / DIN 6885-1 / NF E 22-175, tolerance P9  
 \* Mandatory delivered with finished bores

# E220 VAR 06

## Electro-Magnetic Single Disc Clutch

### Characteristics

- Electrically operated 24 or 103,5 VDC depending size
- Single friction face
- Activated by power on

### Utilisation

- Coupling of two shafts in line
- From size 3200, we recommend to engage the clutch at a lower speed (about 300 min<sup>-1</sup>)

### Particularities

- For dry use
- No residual torque in disengaged position
- Fixed inductor mounted on ball bearings
- Equipped with an elastic coupling

### Adjustments

- Does not require wear compensation

### Maintenance Manual

- SM 307

### Mounting Precautions

- The anti-rotation device of the electromagnet shall be inserted in anti rotation slot, with a side play of 0,5 mm and a 1 mm play to the bottom. This avoids a normal stress on the ball-bearings.
- We strongly recommend to mount a damping elastic slot in the anti-rotation device in case of vibrations
- Device intended for horizontal use, for vertical use please consult the factory

### Power Supply

- For sizes until 1600 :  
CBC 400-24 - CBC 450-24  
CBC 500-24 - CBC 550-24  
CBC 140-5 + CBC 140-T
- For size 3200 and up:  
CBC 140-5

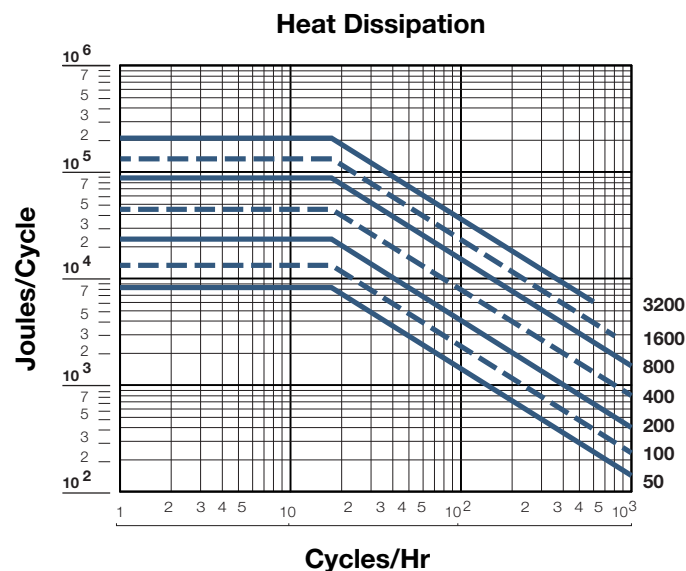

## Electro-Magnetic Single Disc Clutch

**Direct Drive  
with Flexible  
Coupling**

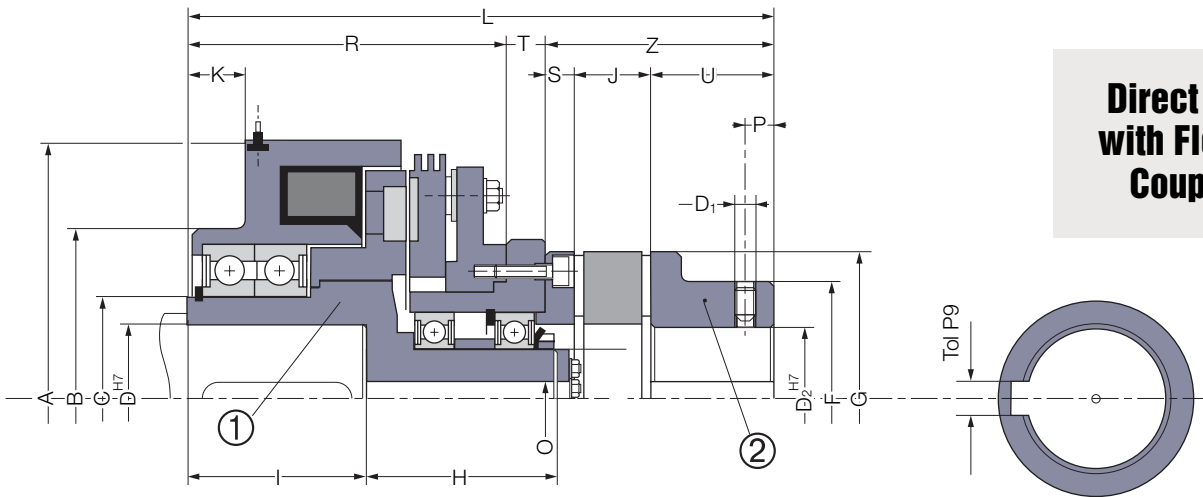

Sizes		50	100	200	400	800	1600	3200
<b>Coupling</b>		38	42	55	65	75	90	100
<b>Nom. Torque</b>	[Nm]	50	100	200	400	800	1600	3200
<b>Max. Speed</b>	[min <sup>-1</sup> ]	4150	3200	2600	2000	1700	1500	1500
<b>Voltage</b>	[VDC]	24	24	24	24	24	24	103.5
<b>Power</b>	P20 [W]	52	60	77	37	47	94	187
	A	139	173	231	260	300	360	450
	B	90	110	155	185	220	265	318
	C	50	65	75	80	90	110	130
	D* min	22	24	30	35	50	55	65
	D* max	35	38	42	55	65	80	90
	D1	M8	M8	M10	M10	M10	M12	M12
	D2 min	12	14	20	22	30	40	50
	D2 max	38	42	55	65	75	90	100
	F	66	75	98	115	135	160	180
	G	80	95	120	135	160	200	225
	H	60	68	78	83	95	108	121
	I	52	62	72	77	87	102	162
	J	24	26	30	35	40	45	50
	K	17,5	19	24,5	21	24	28	77
	L	185	210	250	275	315	365	455
	O	10,5	12,5	16,5	20,5	20,5	21	21
	P	10	10	20	20	20	30	30
	R	95	110	125	135	155	180	250
	S	8	10	13	14	16	19	21
	T	13	14	17	16	19	21	24
	U	45	50	65	75	85	100	110
	Z	77	86	108	124	141	164	181
<b>Inertia</b>	① [kgm <sup>2</sup> ]	0,00270	0,0085	0,0234	0,0635	0,124	0,313	0,781
<b>Inertia</b>	② [kgm <sup>2</sup> ]	0,0055	0,0177	0,0521	0,0584	0,125	0,333	0,901
<b>Weight</b>	[kg]	8,2	14,2	27,7	31,5	50,5	85,5	158
<b>Connection</b>		<b>Cable</b>						

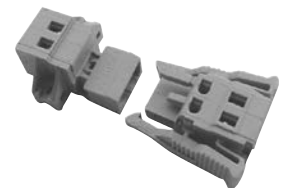

**Connector Options**  
(Delivered without cable)  
2 poles, capacity :  
0,5/2,5mm<sup>2</sup>

Keyways according to  
ISO R773 / BS 4235 / DIN 6885-1 / NF E 22-175, tolerance P9  
\* Mandatory delivered with finished bores

# E140 VAR 00

## Electro-Magnetic Multi Disc Clutch

### Characteristics

- Electrically operated 24 VDC
- Multi disc
- Activated by power on

### Utilisation

- Coupling of a pulley or a hub

### Particularities

- For use in lubricated environments
- Fixed inductor mounted on ball bearings

### Adjustments

- Requires no adjustments at installation
- Automatic wear compensation
- Respect "L" dimension on assembly

### Maintenance Manual

- SM 308

### Mounting Precautions

- Shaft (1) has to be driven, in the opposite case please consult the factory
- Device intended for horizontal use
- The anti-rotation device of the electromagnet shall be inserted in anti rotation slot, with a side play of 0,5 mm and a 1 mm play to the bottom. This avoids a normal stress on the ball-bearings.
- It is forbidden to use in case of vibrations

### Power Supply

- For sizes until 800  
CBC 400-24, CBC 450-24  
CBC 140-5 + CBC 140-T
- For size 1600 and up  
CBC 140-5

Mounting Example

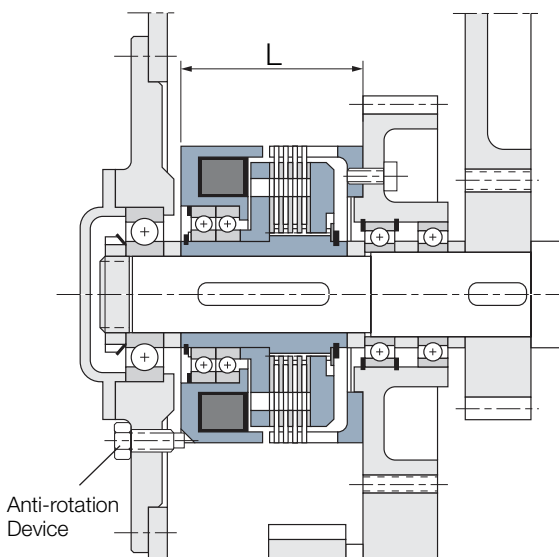

Heat Dissipation

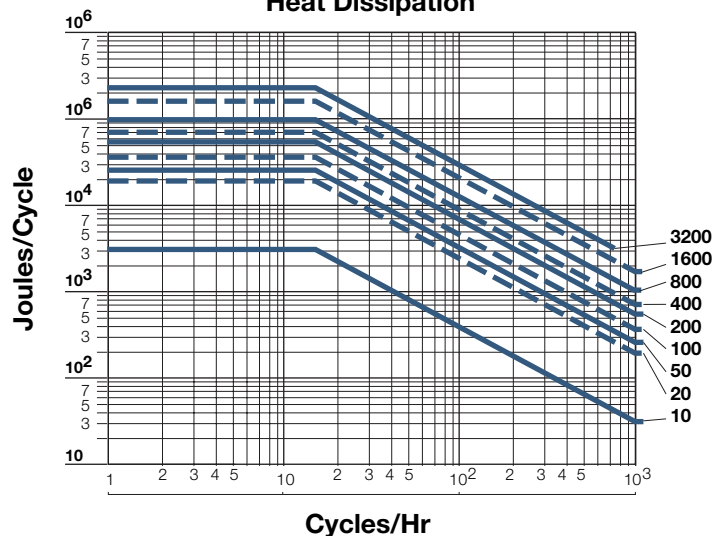



## Electro-Magnetic Multi Disc Clutch

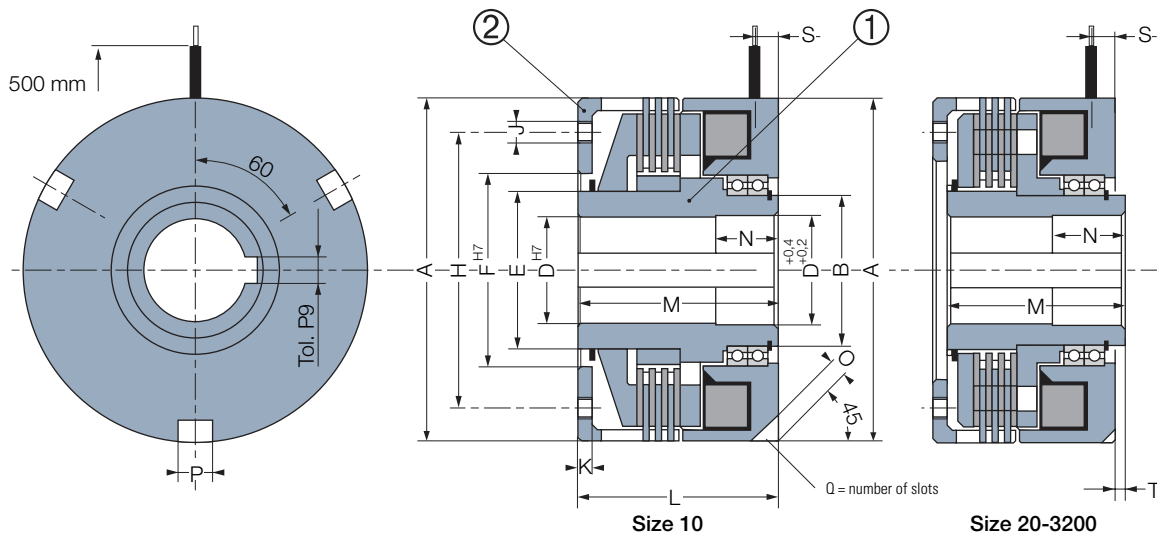

Sizes		10	20	50	100	200	400	800	1600	3200	
<b>Dyn. Nom. Torque</b>	[Nm]	10	20	50	100	200	400	800	1600	3200	
<b>Max. Speed</b>	[min.]	3000	3000	3000	3000	3000	2,200	2,000	1600	1500	
<b>Voltage</b>	[VDC]	24	24	24	24	24	24	24	103,5	103,5	
<b>Power</b>	P20 [W]	26,5	32	37	38	50	54	90	137	189	
	A	70	100	110	132	147	182	202	270	310	
	B	30	40	45	50	55	75	85	110	140	
	D* min	14	17	18	20	20	30	40	45	50	
	D* max	22	30	32	38	42	60	68	90	110	
	E	35	52,5	55	66	55	75	98	135	160	
	F min	45	40	40	54	64	69	100	110	140	
	F max	52	70	70	90	100	120	140	200	220	
	H**	55	85	90	105	120	155	170	235	260	
	J**	4xM5	4xM6	4xM6	6xM8	6xM8	6xM10	6xM10	6xM12	6xM16	
	K	4	5	5	6	7	8	9	12	14	
	L	52	55	60	67	72	93	109	142	157	
	M	52	50	55	60	65	85	100	130	145	
	N	20	20	20	20	25	30	33	45	53	
	O	3	4	4	4	5	6	8	10	10	
	P	6	8	8	10	10	12	14	16	16	
	Q	2	3	3	3	3	3	3	3	3	
	S	7	7	7	7	9	10	10	12	12	
	T	-	-	-	-	0,2	0,2	0,5	0,5	1	
<b>Inertia</b>	① [kgm²]	0,00037	0,0008	0,0017	0,0035	0,0062	0,0235	0,045	0,17	0,32	
<b>Inertia</b>	② [kgm²]	0,0002	0,0006	0,0012	0,0032	0,0042	0,0140	0,023	0,09	0,17	
<b>Weight</b>	[kg]	1,1	2,9	3,9	5,9	7,8	15	22	51	67	
<b>Connection</b>		<b>Leads</b>					<b>Cable</b>				

**Indirect Drives**

### Connector Options

(Delivered without cable)

2 poles, capacity :

0,5/2,5mm<sup>2</sup>

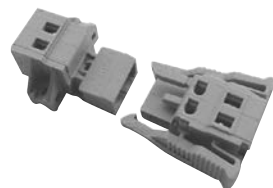

Keyways according to

ISO R773 / BS 4235 / DIN 6885-1 / NF E 22-175, tolerance P9

\* Mandatory delivered with finished bores

\*\* Drive cup is supplied undrilled. Fixing holes are shown for information only

## Electro-Magnetic Toothed Clutch

### Characteristics

- Electrically operated 24 or 103,5 VDC depending size
- Toothed clutch
- Activated by power on

### Utilisation

- Coupling of a pulley or a hub
- Engagement has to be made at standstill or at very low speed, in case of doubt consult the factory
- For wet operation use models VAR n0 For dry operation use models VAR n4 (sealed bearings)

### Particularities

- Positive coupling for drive without slipping
- Standard available for random or synchronised operation (one or more position(s)/rev). Multiposition/rev as option (VAR n0 or VAR n4, “n” indicates number of positions)
- Option : detection disc allows the coupling position to be validated, see E320 VAR504
- Fixed inductor mounted on ball bearings
- Non sealed bearings for use oil environment
- Sealed bearings for dry operation

### Adjustments

- Verify position of tooth “J” prior to installation
- No wear adjustment required

### Maintenance Manual

- SM 309

### Mounting Precautions

- The anti-rotation device of the electromagnet shall be inserted in anti rotation slot, with a side play of 0,5 mm and a 1 mm play to the bottom. This avoids a normal stress on the ball bearings.
- It is forbidden to use in case of vibrations
- Device intended for horizontal use; for vertical use, please consult the factory

### Power Supply

- For sizes until 3200  
CBC 40–24 , CBC 45–24,  
CBC 14–5 + CBC 14–T
- For sizes 6400 to 25600  
CBC 14–5

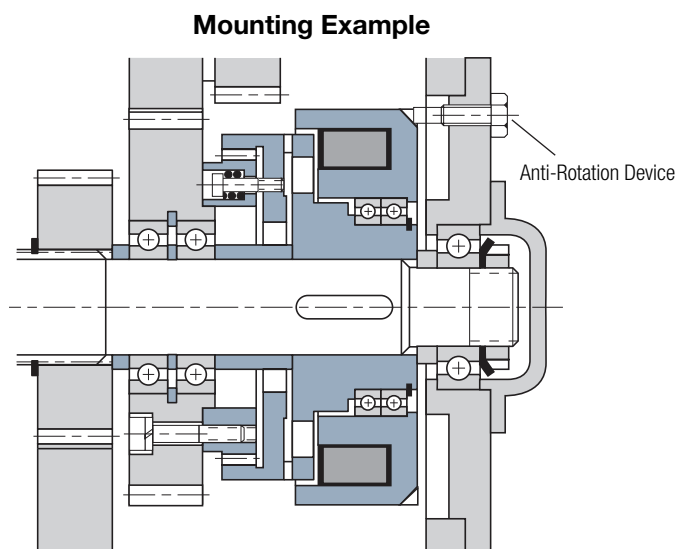

# E320 VAR 00 / VAR 10 | E320 VAR 04 / VAR 14

## Electro-Magnetic Toothed Clutch

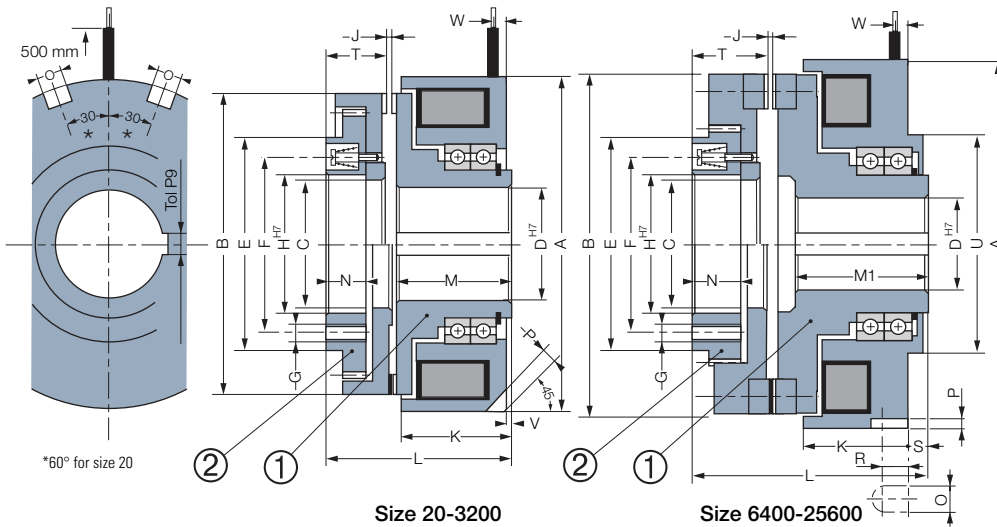

Bearings	Random	Synchronised 1 Rounded
Open	<b>VAR 00</b>	<b>VAR 10</b>
Sealed	<b>VAR 04</b>	<b>VAR 14</b>

**Indirect  
Drives**

Sizes		20	50	100	200	400	800	1600	3200	6400	12800	25600	
<b>Nom. Torque</b>	[Nm]	20	50	100	200	400	800	1,600	3200	6400	12800	25600	
<b>Max. Speed</b>	VAR 00 / 10 [min <sup>-1</sup> ]	-	5000	4300	3600	3300	2,700	2,100	1800	1500	1500	1200	
	VAR 04 / 14 [min <sup>-1</sup> ]	5000	3900	3500	2800	2600	2100	1500	1400	1000	-	-	
<b>Voltage</b>	[VDC]	24	24	24	24	24	24	24	24	24	103,5	103,5	
<b>Power</b>	P20 [W]	15	21	26	29	48	54	64	74,5	101	140	248	
	A	72	82	100	115	125	153	202	235	340	410	490	
	B	66	75	90	105	115	140	185	215	320	385	460	
	C	28	40	49,5	58	63	76	99	117	153	180	220	
	D* min	10	20	20	25	30	30	50	50	80	90	110	
	D* max	22	30	32	42	46	55	80	85	110	125	150	
	E	-	65,5	75,5	85,5	100,5	115,5	155,5	180,5	215,5	275,5	340,5	
	F	45	55	64	75	85	100	135	155	190	250	300	
	G	3xM4	4xM5	4xM5	4xM6	6xM6	6xM8	6xM10	6xM10	12xM12	12xM16	16xM46	
	H	32	45	53	65	70	85	115	130	153	190	235	
	J	0,3	0,4	0,5	0,5	0,5	0,6	0,7	0,8	1	1	1	
	K	33	28,5	32	37	38	45,5	60,5	72	79	91	106	
	L	47	44	50	57,5	60	74	97	120	174	211	295	
	M	34	29	32,3	37,3	38,3	46	61	72,3	-	-	-	
	M1	-	-	-	-	-	-	-	-	100	125	205	
	N	5,4	8	10	12	12,5	17	21	28	35	41	55	
	O	6	6	10	10	10	10	10	12	18	18	18	
	P	3,5	3	4	4	4	5	6	8	8	10	12	
	R	-	-	-	-	-	-	-	-	12	15	18	
	S	-	-	-	-	-	-	-	-	11	18	68,5	
	T	12,8	14	16,5	19	20	26	34	45	58,5	70	87,5	
	U	-	-	-	-	-	-	-	-	187	235	300	
	V	2	-	-	-	-	-	-	-	-	-	-	
	W	7	7	7	7	7	10	12	15	19	22	25	
<b>Inertia</b>	① [kgm <sup>2</sup> ]	0,00008	0,0001	0,0003	0,0008	0,0011	0,0032	0,015	0,0339	0,319	0,775	2,000	
<b>Inertia</b>	② [kgm <sup>2</sup> ]	0,00015	0,0002	0,0006	0,001	0,002	0,007	0,030	0,0629	0,406	1,08	2,660	
<b>Weight</b>	[kg]	1	1,2	2	3	4	7	14	29,5	82	145	254	
<b>Connection</b>		<b>Leads</b>						<b>Cable</b>					

Keyways according to ISO R773 / BS 4235 / DIN 6885-1 / NF E 22-175, tolerance P9  
 \* Mandatory delivered with finished bores

**Connector Options**  
 (Delivered without cable)  
 2 poles, capacity :  
 0,5/2,5mm<sup>2</sup>

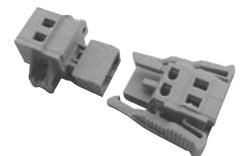

# E320 VAR 504

## Electro-Magnetic Toothed Clutch

### Characteristics

- Electrically operated 24 or 103,5 VDC depending size
- Toothed clutch
- Activated by power on

### Utilisation

- Coupling of a pulley or a hub
- Engagement has to be made at standstill or at very low speed, in case of doubt consult the factory
- For wet operation use models VAR n0  
For dry operation use models VAR n4 (sealed bearings)

### Particularities

- Positive coupling for drive without slipping
- Standard available for random or synchronised operation (one or more position(s)/rev).  
Multiposition/rev as option (VAR n0 or VAR n4, "n" indicates number of positions)
- Fixed inductor mounted on ball bearings
- Non sealed bearings for use oil environment
- Sealed bearings for dry operation

### Adjustments

- Verify position of tooth "J" prior to installation
- No wear adjustment required

### Maintenance Manual

- SM 309

### Mounting Precautions

- The anti-rotation device of the electromagnet shall be inserted in anti rotation slot, with a side play of 0,5 mm and a 1 mm play to the bottom. This avoids a normal stress on the ball bearings.
- It is forbidden to use in case of vibrations
- Device intended for horizontal use; for vertical use, please consult the factory

### Power Supply

- For sizes until 3200  
CBC 400-24 , CBC 450-24,  
CBC 140-5 + CBC 140-T
- For sizes 6400 to 25600  
CBC 140-5

### Mounting Example

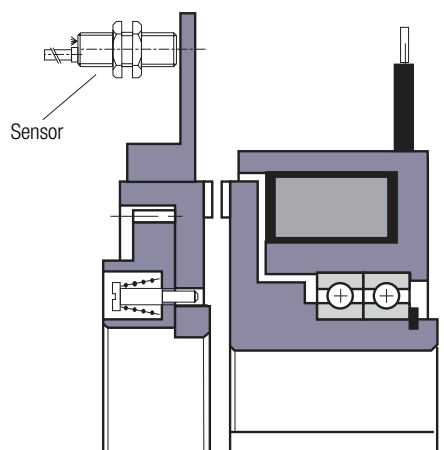

### Connector Options

(Delivered without cable)

2 poles, capacity : 0,5/2,5mm<sup>2</sup>

## Electro-Magnetic Toothed Clutch

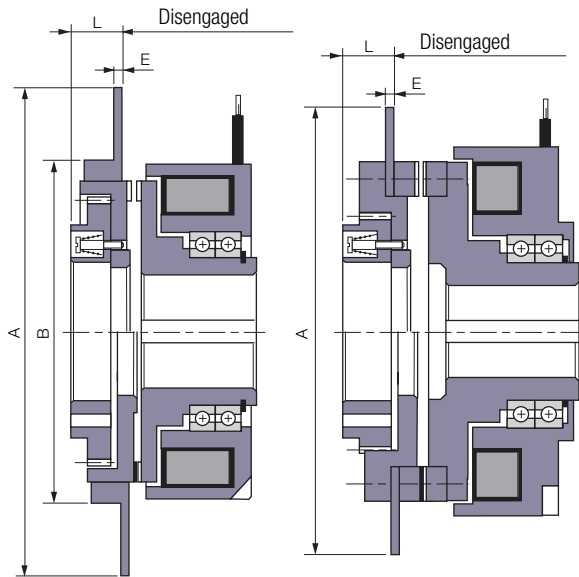

Size 50 - 1600

Size 3200 - 25600

Other dimensions, see page 39

### Inductive Proximity Sensor

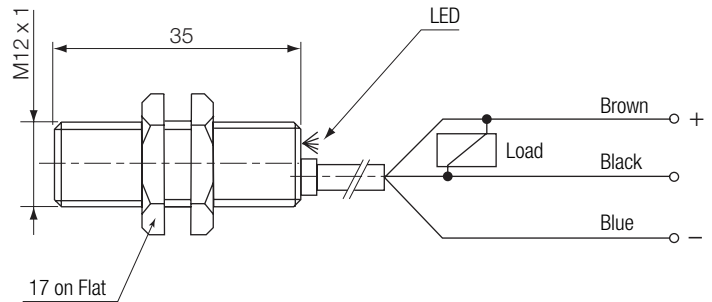

Part number BT768000124

Sizes	50	100	200	400	800	1600	3200	6400	12800	25600
<b>A</b>	135	152	168	178	205	250	288	400	465	540
<b>B</b>	88	104	120	132	158	205	235	—	—	—
<b>E</b>	3	3	3	3	3	3	3	5	5	5
<b>L</b>	12	14	15,5	16	20,5	28	40	37,5	42	59,5
<b>Inertia*</b>	[kgm <sup>2</sup> ]	0,0003	0,0005	0,0007	0,0010	0,0020	0,0043	0,017	0,081	0,242

\* Value to be added to Inertia (2), see page 39.

### INDUCTIVE PROXIMITY SENSOR with built-in electronic board

#### Characteristics

Rate operating distance (steel target)	2 mm
Monting	shilded
Switching element function	Normally open
Cable	NPN, 3 x 0,34 mm <sup>2</sup> , 2 m
Usable supply voltage	18 V... 30 VDC
Ripple voltage	10 %
No load supply voltage	10 mA
Rated operational current	120 mA
Voltage drop	1,5 V
Off-state current	10 µA
Short circuit protection	yes
Overload protection	yes
Reverse battery protection	yes
Wire break resistance	yes
EMC	Group A
Operating frequency	2000 Hz
Hysteresis	15 %
Temperature drift	10 %
Repeat accuracy	10 %
Housing	Nickel-plated brass
Front cap	PBTP
Degree of protection (EN 60529)	IP 67
Ambiant air temperature	-25°C... +70°C
Part number	BT768 000 124

# E320 VAR 05 / VAR 15

---

## Electro-Magnetic Toothed Clutch

### Characteristics

- Electrically operated 24 VDC
- Toothed clutch
- Activated by power on

### Utilisation

- Coupling of two shafts in line
- Engagement has to be made at standstill or at very low speed, in case of doubt consult the factory

### Particularities

- Positive coupling for drive without slipping
- Standard available for random or synchronised operation (one or more position(s)/rev). Multiposition/rev as option (VAR n5, "n" indicates number of positions)
- Option : detection disc allows the coupling position to be validated, see E320 VAR504 page 41
- Fixed inductor mounted on ball bearings
- Sealed bearings
- Equipped with an elastic coupling

### Adjustments

- No wear adjustment required

### Maintenance Manual

- SM 309

### Mounting Precautions

- The anti-rotation device of the electromagnet shall be inserted in anti rotation slot, with a side play of 0,5 mm and a 1 mm play to the bottom. This avoids a normal stress on the ball-bearings.
- It is forbidden to use in case of vibrations
- Device intended for horizontal use; for vertical use, please consult the factory

### Power Supply

- For sizes until 3200  
CBC 400-24 - CBC 450-24,  
CBC 140-5 + CBC 140-T
- For size 6400 to 25600  
CBC 140-5

## Electro-Magnetic Toothed Clutch

**Direct Drive  
with Flexible  
Coupling**

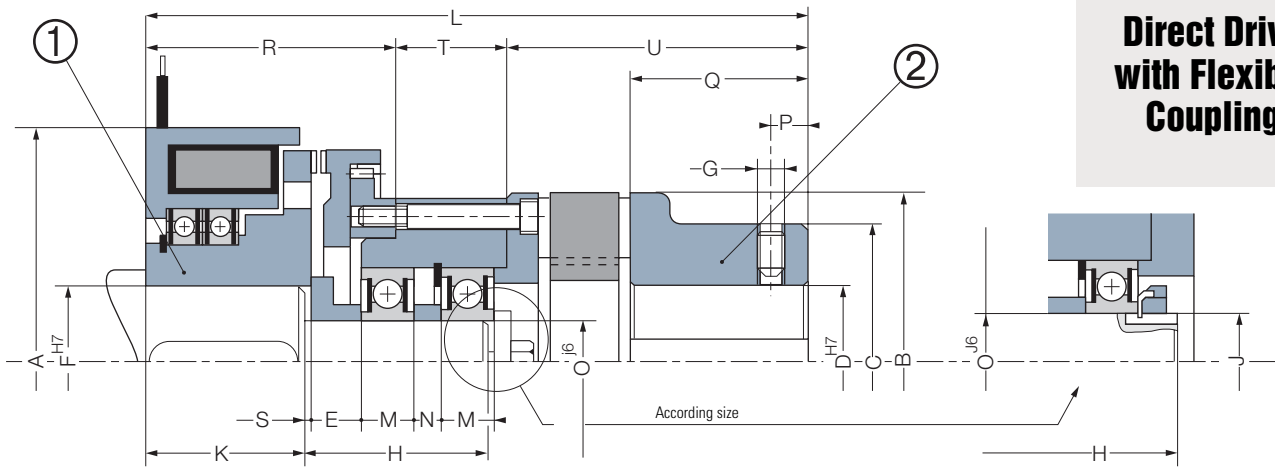

Sizes		50	100	200	400	800	1600	3200	6400	12800	25600	
<b>Nom. Torque</b>	[Nm]	50	100	200	400	800	1600	3200	6400	12800	25600	
<b>Coupling</b>		28/38	38	42	48	55	75	90	125	160	180	
<b>Max. Speed</b>	[min.]	3900	3500	2800	2600	2100	1500	1400	1000	1500	1200	
<b>Voltage</b>	[VDC]	24	24	24	24	24	24	24	24	103,5	103,5	
<b>Power</b>	P20 [W]	21	26	29	48	54	64	74,5	101	160	248	
	A	82	100	115	125	153	202	235	340	410	490	
	B	65	80	95	105	120	160	200	290	335	460	
	C	65	66	75	85	98	135	160	230	180	220	
	D* min	10	12	14	15	20	30	40	60	80	85	
	D* max	40	38	42	48	55	75	90	145	160	180	
	E	17	10,7	13,7	21,7	28	19	20,7	45	48	37	
	F* min	20	20	25	30	30	50	55	80	90	110	
	F* max	30	32	42	46	55	80	85	110	125	150	
	G	M8	M8	M8	M8	M10	M10	M12	M12	M16	M16	
	H	41	41,7	44,7	47,7	54	68	107	160	173	179	
	J	-	-	-	-	-	-	M55X2	M65X2	M80X2	M90X2	
	K	28	31,3	36,3	37,3	45	60	70,3	98	123	203	
	L	135	154	171	184	211	273	332	432	528	690	
	M	12	12	12	13	13	16	21	23	26	30	
	N	-	7	7	-	-	17	28	52	53	62	
	O	20	20	25	30	30	50	55	65	80	90	
	P	10	10	10	10	20	20	30	30	40	40	
	Q	35	45	50	56	65	85	100	140	175	195	
	R	44	50	57,5	60	74	97	120	174	211	295	
	S	1	1	1	1	1	1	2	2	2	2	
	T	①	29	27	27,5	29	29	35	48	30	32	76
	U	62	77	86	95	108	141	164	228	285	319	
<b>Inertia</b>	① [kgm <sup>2</sup> ]	0,0001	0,0003	0,0008	0,0011	0,0032	0,015	0,0353	0,324	0,775	2,000	
<b>Inertia</b>	② [kgm <sup>2</sup> ]	0,0009	0,0027	0,0057	0,0088	0,0219	0,0864	0,229	1,197	TBD	TBD	
<b>Weight</b>	[kg]	2,5	4,5	6,8	8,3	15,5	31	61	161	TBD	TBD	
<b>Connection</b>		<b>Leads</b>				<b>Cable</b>						

Keyways according to  
ISO R773 / BS 4235 / DIN 6885-1 / NF E 22-175, tolerance P9  
\* Mandatory delivered with finished bores

**Connector Options**  
(Delivered without cable)  
2 poles, capacity :  
0,5/2,5mm<sup>2</sup>

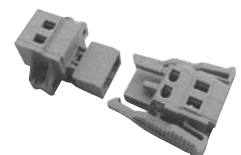

# E330 VAR 04 / VAR 14

## Electro-Magnetic Toothed Clutch

### Characteristics

- Electrically operated 103,5/48 or 207/103,5 VDC depending size
- Toothed clutch
- Activated by spring pressure

### Utilisation

- Coupling of a pulley or a hub
- Engagement has to be made at standstill or at very low speed, in case of doubt consult the factory
- Destined to remain coupled over long periods

### Particularities

- This device works with two voltages: one for disengagement, one for position maintain
- Positive coupling for drive without slipping
- Standard available for random or synchronised operation (one or more position(s)/rev). Multiposition/rev as option (VAR n4, "n" indicates number of positions)
- Option : detection disc allows the coupling position to be validated, see E330 VAR504
- Fixed inductor mounted on ball bearings
- Sealed bearings

### Adjustments

- Verify position of tooth "Q" prior to installation
- No wear adjustment required

### Maintenance Manual

- SM 310

### Mounting Precautions

- The anti-rotation device of the electromagnet shall be inserted in anti rotation slot, with a side play of 0,5 mm and a 1 mm play to the bottom. This avoids a normal stress on the ball-bearings.
- It is forbidden to use in case of vibrations
- Device intended for horizontal use; for vertical use, please consult the factory
- The customers mounting method must take into account the axial thrust

### Power Supply CBC 140-5

- Overexcitation delay: 0,5 s (size 50) to 2 s (size 12800)

### Mounting Example

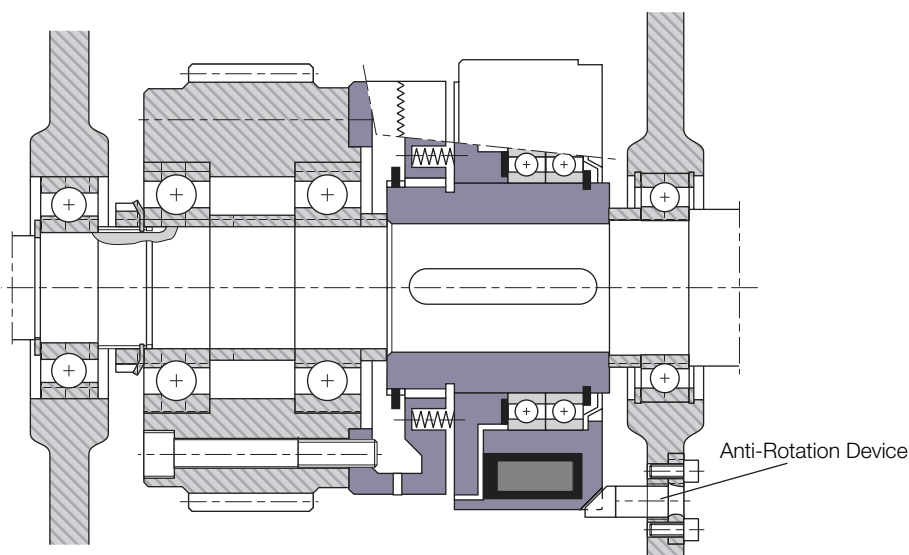



## Electro-Magnetic Toothed Clutch

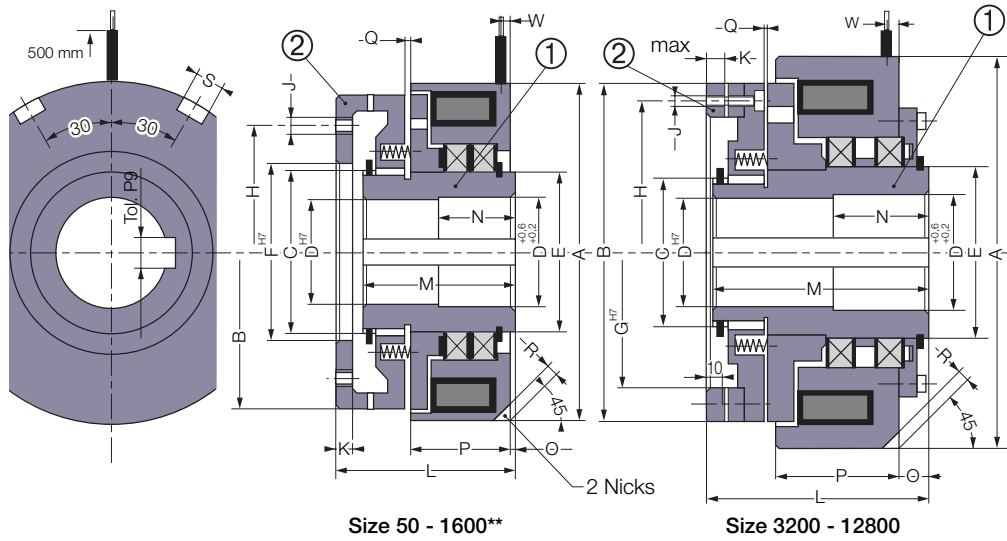

Sealed Bearings	Random	Synchronised 1 Rounded
	VAR 04	VAR 14

**Indirect Drive**

Size 50 - 1600\*\*

Size 3200 - 12800

Sizes		50	100	200	400	800	1600	3200	6400	12800	
Nom. Torque	[Nm]	50	100	200	400	800	1600	3200	6400	12800	
Max. Speed	[min <sup>-1</sup> ]	4300	3600	3300	2600	2000	1800	1450	1200	1000	
U pull in / holding	[VCD]	103,5/48	103,5/48	103,5/48	103,5/48	103,5/48	103,5/48	207/103,5	207/103,5	207/103,5	
Power pull in	P20 [W]	108	170	182	311	330	373	640	920	1224	
Holding	P20 [W]	20,5	32,4	34,6	59	63	71	160	230	306	
	A	100	115	125	153	202	245	290	350	425	
	B	90	105	115	140	185	225	265	320	385	
	C	45	55	60	75	100	105	125	145	175	
	D* min	19	24	28	28	38	48	65	80	100	
	D* max	30	38	42	55	75	80	95	110	130	
	E	45	55	60	75	105	110	130	150	180	
	F min	40	45	50	65	105	110	-	-	-	
	F max	58	70	80	100	130	155	-	-	-	
	G	-	-	-	-	-	-	215	260	315	
	H**	68	82	92	110	148	175	240	290	355	
	J**	4xM6	4xM6	6xM6	6xM8	6xM10	6xM12	12xM12	12xM14	12xM16	
	K	5	6	6	7	8	12	15	18	24	
	L	58	63	65	80	100	145	165	200	245	
	M	51	55	57	71	90	130	160	198	240	
	N	20	21	23	25	30	48	55	65	78	
	O	1,7	1,7	0,5	0,7	0,5	15	15	22	23	
	P	32	37	38	45,5	60,5	75	90	107	133,5	
	Q	1	1,1	1,2	1,3	1,3	2	2,3	2,7	3,2	
	R	4	4	4	5	6	7	8	10	12	
	S	10	10	10	10	10	12	16	18	20	
	W	7	7	7	7	10	12	15	19	22	
Axial load on drive cup 2	[daN]	30	45	65	115	180	330	900	1500	2200	
Inertia	① [kgm <sup>2</sup> ]	0,00100	0,00160	0,0027	0,0087	0,0330	0,0845	0,2150	0,554	1,370	
Inertia	② [kgm <sup>2</sup> ]	0,00034	0,00073	0,0010	0,0025	0,0095	0,022	0,0418	0,104	0,290	
Weight	[kg]	2,4	3,4	4,2	8	18	33,5	55,5	98	178	
Connection		Leads					Cable				

Keyways according to ISO R773 / BS 4235 / DIN 6885-1 / NF E 22-175, tolerance P9

\* Mandatory delivered with finished bores

\*\* Drive cup sizes 50 to 1600 supplied non drilled. Fixing holes are shown for information only

### Connector Options

(Delivered without cable)

2 poles, capacity :  
0,5/2,5mm<sup>2</sup>

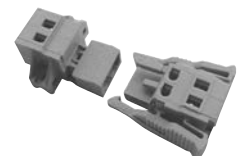

# E330 VAR 504

## Electro-Magnetic Toothed Clutch

### Characteristics

- Electrically operated 103,5/48 or 207/103,5 VDC depending size
- Toothed clutch
- Activated by spring pressure

### Utilisation

- Coupling of a pulley or a hub
- Engagement has to be made at standstill or at very low speed, in case of doubt consult the factory
- Destined to remain coupled over long periods

### Particularities

- This device works with two voltages: one for disengagement, one for position maintain
  - Positive coupling for drive without slipping
  - Standard available for random or synchronised operation (one or more position(s)/rev). Multiposition/rev as option (VAR n4, "n" indicates number of positions)
- Fixed inductor mounted on ball bearings  
Sealed bearings

### Adjustments

- Verify position of tooth "Q" prior to installation
- No wear adjustment required

### Maintenance Manual

- SM 310

### Mounting Precautions

- The anti-rotation device of the electromagnet shall be inserted in anti rotation slot, with a side play of 0,5 mm and a 1 mm play to the bottom. This avoids a normal stress on the ball-bearings.
- It is forbidden to use in case of vibrations
- Device intended for horizontal use; for vertical use, please consult the factory
- The customers mounting method must take into account the axial thrust

### Power Supply CBC 140-5

- Overexcitation delay: 0,5 s (size 50) to 2 s (size 12800)

### Mounting Example

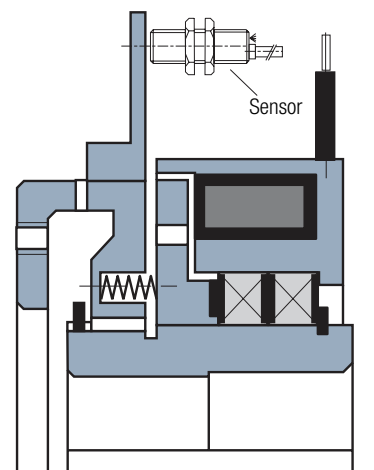

### Connector Options

(Delivered without cable)

2 poles, capacity : 0,5/2,5mm<sup>2</sup>

## Electro-Magnetic Toothed Clutch

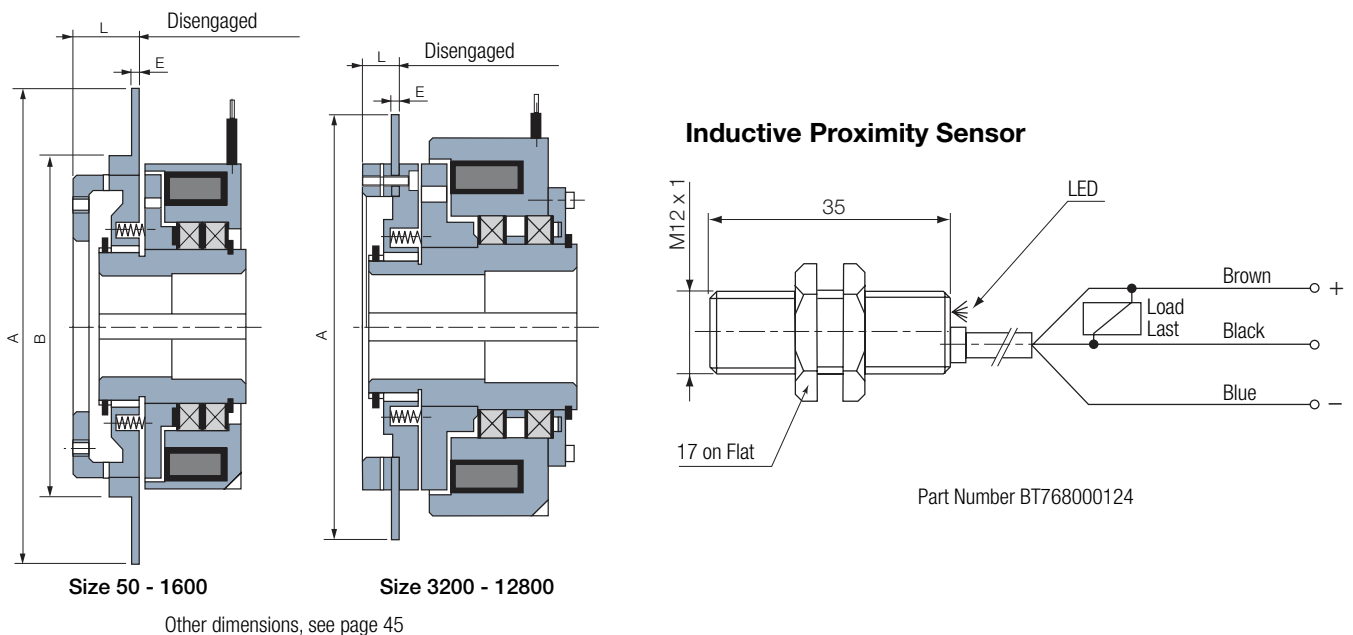

Sizes	50	100	200	400	800	1600	3200	6400	12800
<b>A</b>	152	168	178	205	250	300	344	400	465
<b>B</b>	104	120	132	158	205	245	-	-	-
<b>E</b>	3	3	3	3	3	3	4	5	5
<b>L</b>	23	23	24,5	32	37	53	42,5	48	62
<b>Inertia*</b>	[kgm <sup>2</sup> ]	0,0003	0,0005	0,0007	0,0010	0,0020	0,0043	0,017	0,142

\* Value to be added to Inertia (2), see page 45.

### INDUCTIVE PROXIMITY SENSOR with built-in electronic board

#### Characteristics

Rate operating distance (steel target)	2 mm
Mounting	shilded
Switching element function	Normally open
Cable	NPN, 3 x 0,34 mm <sup>2</sup> , 2 m
Usable supply voltage	18 V... 30 VDC
Ripple voltage	10 %
No load supply voltage	10 mA
Rated operational current	120 mA
Voltage drop	1,5 V
Off-state current	10 μA
Short circuit protection	yes
Overload protection	yes
Reverse battery protection	yes
Wire break resistance	yes
EMC	Group A
Operating frequency	2000 Hz
Hysteresis	15 %
Temperature drift	10 %
Repeat accuracy	10 %
Housing	Nickel-plated brass
Front cap	PBTP
Degree of protection (EN 60529)	IP 67
Ambient air temperature	-25°C... +70°C
Part number	BT768000124

# E330 VAR 05 / VAR 15

---

## Electro-Magnetic Toothed Clutch

### Characteristics

- Electrically operated 103,5/48 or 207/103,5 VDC depending size
- Toothed clutch
- Activated by spring pressure

### Utilisation

- Coupling of two shafts in line
- Coupling has to be made at standstill or at very low speed, in case of doubt consult the factory
- Destined for remain connected long periods

### Particularities

- This device works with two voltages: one for disengagement, one for position maintain
- Positive coupling for drive without slipping
- Option : detection disc allows the coupling position to be validated, see E330 VAR504 page 47
- Fixed inductor mounted on ball bearings
- Sealed bearings
- Equipped with an elastic coupling

### Adjustments

- No wear adjustment required

### Maintenance Manual

- SM 310

### Mounting Precautions

- The anti-rotation device of the electromagnet shall be inserted in anti rotation slot, with a side play of 0,5 mm and a 1 mm play to the bottom. This avoids a normal stress on the ball-bearings.
- It is forbidden to use in case of vibrations
- Device intended for horizontal use; for vertical use, please consult the factory

### Power Supply CBC 140-5

- Overexcitation delay: 0,5 s (size 50) to 2 s (size 6400)

## Electro-Magnetic Toothed Clutch

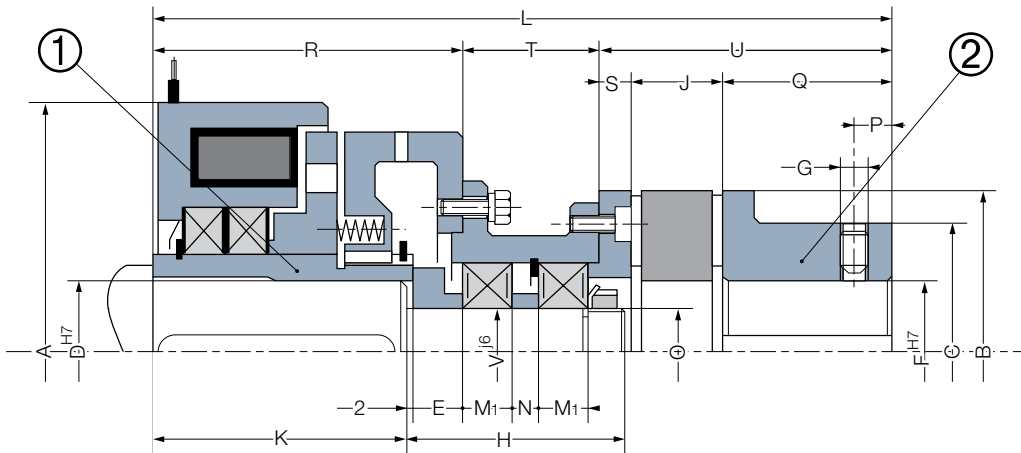

Sizes		50*	100	200	400	800	1600	3200	6400
Nom. Torque	[Nm]	50	100	200	400	800	1600	3200	6400
Coupling		28/38	38	42	55	75	90	110	140
Max. Speed	[min. <sup>-1</sup> ]	4300	3600	3300	2600	2000	1800	1450	1200
U pull in / holding	[VDC]	103,5/48	103,5/48	103,5/48	103,5/48	103,5/48	103,5/48	207/103,5	207/103,5
Power pull in	P20 [W]	108	170	182	311	330	373	640	920
Holding	P20 [W]	20,5	32,4	34,6	59	63	71	160	230
	A	100	115	125	153	202	245	290	350
	B	65	80	95	120	160	200	255	320
	C	65	66	75	98	135	160	200	255
	D** min	20	20	25	35	40	48	70	85
	D** max	30	38	42	55	70	80	95	110
	E	9	8	8	7	10	11	21	21
	F min	10	12	14	20	30	40	60	60
	F max	40	38	42	55	75	90	125	160
	G	M8	M8	M8	M10	M10	M12	M12	M12
	H	34	54	57	66	82	100	109	118
	J	20	24	26	30	40	45	55	65
	K	49	53	55	69	88	128	158	196
	L	149	181	191	235	302	384	460	555
	M1	12	14	15	17	23	25	63,5	68,3
	N	-	7	7	12	12	24	-	-
	O	-	M20X1	M25X1,5	M35X1,5	M40X1,5	M45X1,5	M70X2	M80X2
	P	10	10	10	20	20	30	30	30
	Q	35	45	50	65	85	100	120	155
	R	58	63	65	80	100	145	165	200
	S	7	8	10	13	16	19	24	31
	T	29	41	40	47	61	75	96	104
	U	62	77	86	108	141	164	199	251
	V	20	20	25	35	40	45	70	80
Inertia	① [kgm <sup>2</sup> ]	0,00100	0,0016	0,0027	0,0087	0,033	0,0845	0,2212	0,565
Inertia	② [kgm <sup>2</sup> ]	0,00107	0,00293	0,0055	0,0196	0,150	0,162	0,522	1,220
Weight	[kg]	3,6	6	8	17,2	35	61,5	108,3	170
Connection		Leads				Cable			

**Direct Drive  
with Flexible  
Coupling**

Keyways according to ISO R773 / BS 4235 / DIN 6885-1 / NF E 22-175, tolerance P9  
 \* For size 50, bearings are located axially by washer and screw (instead of threaded nut)  
 \*\* Mandatory delivered with finished bores

**Connector Options**  
 (Delivered without cable)  
 2 poles, capacity :  
 0,5/2,5mm<sup>2</sup>

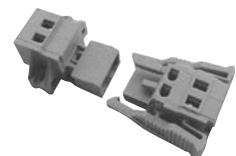

# P130 VAR 00 / VAR 02

## Pneumatic Multi Disc Clutch

### Characteristics

- Pneumatically operated
- Multi disc
- Function under pressure

### Utilisation

- Coupling of a pulley or a hub
- Device destined for industrial applications
- VAR 02 designed for use on diesel engines. Friction discs are of solid construction

### Particularities

- For dry use
- Low residual torque
- Shaft driven
- Good graduality

### Adjustments

- None required, automatic wear compensation by piston movement

### Maintenance Manual

- SM 302

### Mounting Precautions

- Provide shaft seals in order to avoid loss of pressure (see ST 0119-01)
- Device intended for horizontal use, for vertical use please consult the factory

### Power Supply

- Oiled compressed air. For dry air please consult factory
- Can be operated with hydraulic oil, in that case please consult the factory

Mounting Example

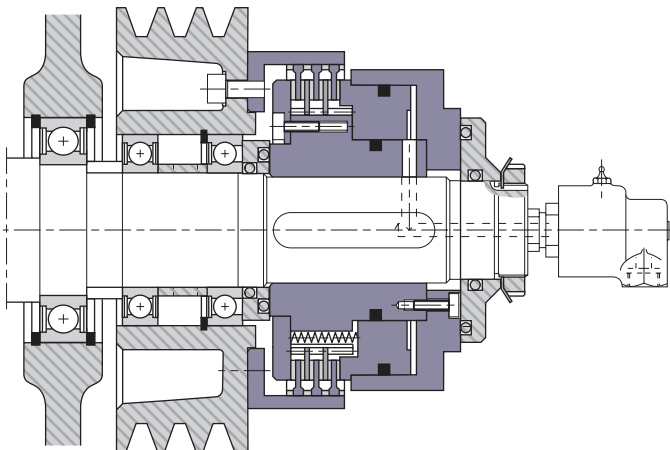

Heat Dissipation

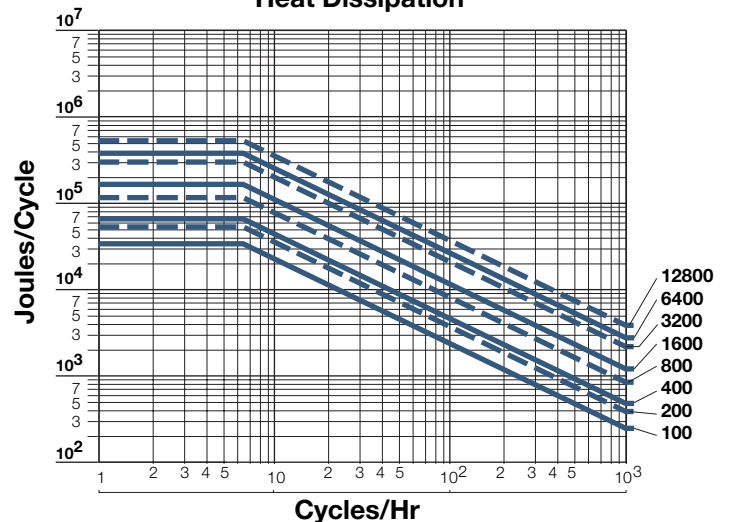

# P130 VAR 00 / VAR 02

## Pneumatic Multi Disc Clutch

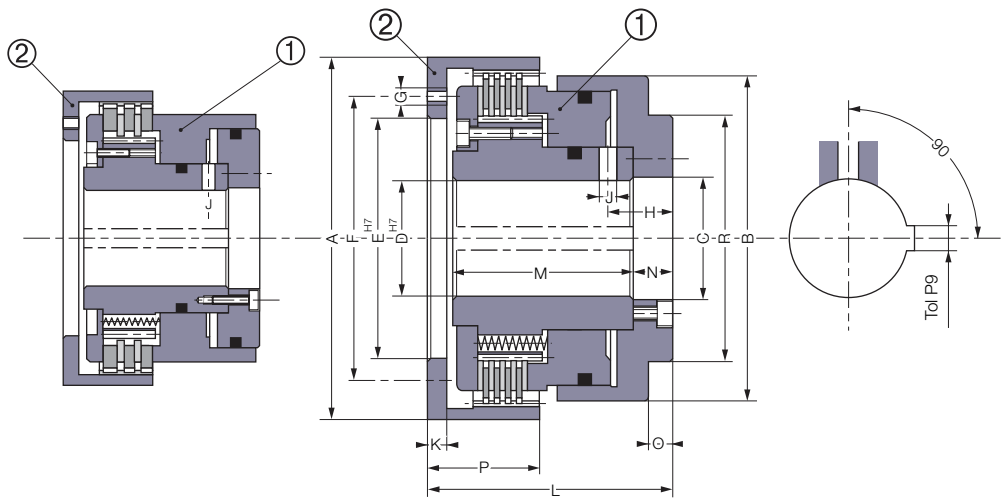

Size 100 - 1600

Size 3200 - 12800

**VAR 00 =  
STANDARD  
VAR 02 for  
Diesel Engines  
VAR 02**

**Indirect Drive**

Sizes		100	200	400	800	1600	3200	6400	12800
<b>Nom. Torque</b>	[Nm]	100	200	400	800	1600	3200	6400	12800
<b>Max. Speed</b>	[min <sup>-1</sup> ]	4800	3900	3500	2700	2400	2000	1500	1,200
<b>Operating Pressure</b>	[bar]	5	5	5	5	5	5	5	5
A		132	162	180	222	255	290	335	390
B		110	135	150	189	220	262	315	380
C		41	51	59	86	101	106	111	132
D* min		24	34	34	39	39	50	60	70
D* max		40	50	58	85	100	105	110	130
E min		50	64	69	85	101	120	130	180
E max		85	105	115	150	175	220	260	280
F*		100	122	135	170	200	250	290	320
G*		6xM6	6xM8	6xM8	6xM10	6xM12	6xM16	8xM16	12xM16
H		19	23	23	26	30,5	60	31	39
J		5	6	6	6	8	8	10	12
K		6	9	8	11	10	14	16	18
L		81	89	96	118	135	155	170	190
M		63,5	68	75	92	105	120	130	145
N		9,5	11	11	13	16	18	21	23
O		-	-	-	-	-	8	8	-
P		39	41	46	58	70	82	95	108
R		-	-	-	-	-	200	220	-
<b>Stroke Volume</b>	new [cm <sup>3</sup> ]	5,2	12	20	22	32	80	207	958
<b>Stroke Volume</b>	max [cm <sup>3</sup> ]	22	43,8	59	81	150	320	650	1760
<b>Inertia</b>	① [kgm <sup>2</sup> ]	0,0061	0,0122	0,0253	0,0835	0,1818	0,3900	0,7700	1,47
<b>Inertia</b>	VAR 00 [kgm <sup>2</sup> ]	0,0046	0,0126	0,0219	0,0598	0,1090	0,1828	0,3557	0,93
<b>Inertia</b>	VAR 02 [kgm <sup>2</sup> ]	0,0046	0,0133	0,0215	0,0598	0,1090	-	-	-
<b>Weight</b>	[kg]	6	9,5	13	25	39	55	87	125
<b>Connection</b>		<b>Via Shaft</b>							

Keyways according to  
ISO R773 / BS 4235 / DIN 6885-1 / NF E 22-175, tolerance P9

\*Drive sup is supplied undrilled. Fixing holes are shown for information only

# P140 VAR 00 / VAR 02

## Pneumatic Multi Disc Clutch

### Characteristics

- Pneumatically operated
- Multi disc
- Function under pressure

### Utilisation

- Coupling of a pulley or a hub
- Device destined for industrial applications
- VAR 02 designed for use on diesel engines. Friction discs are of solid construction

### Particularities

- For dry use
- Low residual torque
- Stationary compressed air distribution included
- Good graduality

### Adjustments

- None required, automatic wear compensation by piston movement

### Maintenance Manual

- SM 303

### Mounting Precautions

- The ball bearing life is a function of the speed and pressure, refer to curve shown on page 56
- The anti-rotation device of the cylinder shall be inserted in anti rotation slot, with a side play of 0,5 mm and a 1 mm play to the bottom. This avoids a normal stress on the ball-bearings.
- We strongly recommend to mount a damping elastic slot in the anti-rotation device in case of vibrations
- Device intended for horizontal use, for vertical use please consult the factory

### Power Supply

- Oiled compressed air. For dry air please consult factory
- Can be operated with hydraulic oil. In that case, please consult the factory

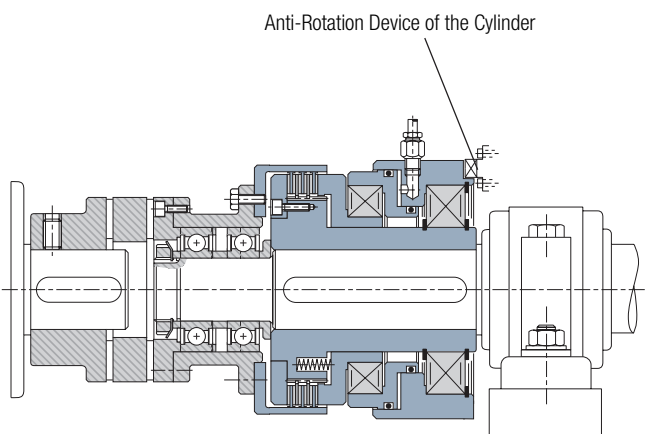

Ball Bearing Life for Nominal Pressure

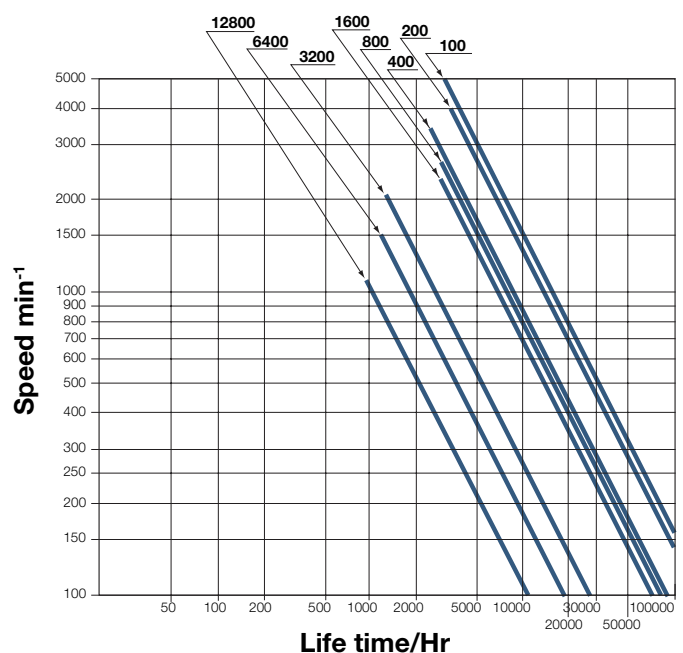



# P140 VAR 00 / VAR 02

## Pneumatic Multi Disc Clutch

**VAR 00 =  
STANDARD  
VAR 02 for  
Diesel Engines  
VAR 02**

**Indirect Drive**

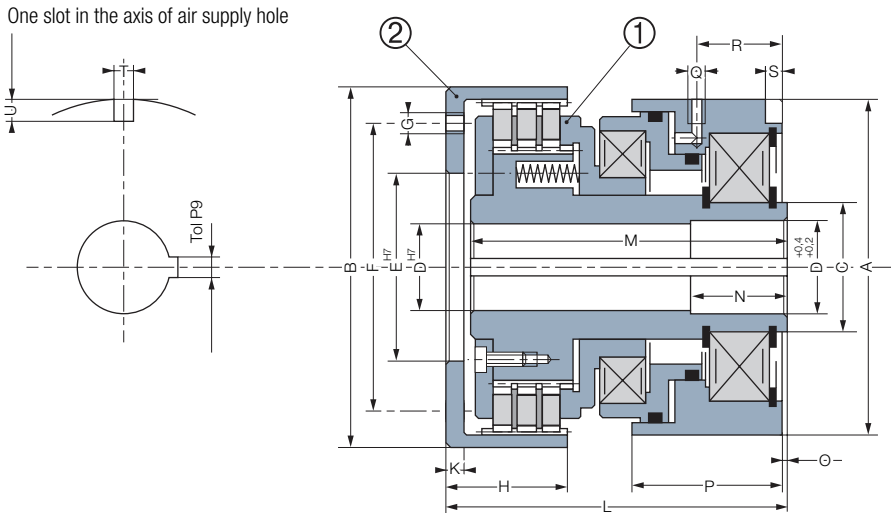

Sizes		100	200	400	800	1600	3200	6400	12800	
<b>Nom. Torque</b>	[Nm]	100	200	400	800	1600	3200	6400	12800	
<b>Max. Speed</b>	[min <sup>-1</sup> ]	4800	3900	3500	2700	2400	2000	1500	1200	
<b>Operating Pressure</b>	[bar]	4,5	5	5	5	5	5	5	5	
A		132	149	166	198	234	270	324	398	
B		132	162	180	222	255	290	335	390	
C		55	65	80	95	110	130	150	180	
D* min		24	35	35	40	40	50	65	80	
D* max		40	50	60	75	90	105	120	140	
E min		50	64	69	85	101	120	130	180	
E max		85	105	115	150	175	220	260	280	
F**		100	122	135	170	200	250	290	320	
G**		6xM6	6xM8	6xM8	6xM10	6xM12	6xM16	8xM161	2xM16	
H		39	41	46	58	70	82	95	108	
K		6	9	8	11	10	14	16	18	
L		125	134	148	185	215	260	290	335	
M		117	124	138	172	202	243	271	313	
N		30	35	38	52	62	80	80	92	
O		-	-	0,5	3	5	5	5	10	
P		62	64	69,5	86	104	118	129	144	
Q		Rp1/8	Rp1/8	Rp1/4	Rp1/4	Rp1/4	Rp3/8	Rp3/8	Rp3/8	
R		35	37	41	52	63	70	77	83	
S		5,5	4,5	6	7,5	8,5	8,5	9	12	
T		8	8	10	12	12	16	16	20	
U		12	12,5	11	11	14	17	23	22	
<b>Stroke Volume</b>	new	[cm <sup>3</sup> ]	7,5	10,5	20	26	34	85	210	260
<b>Stroke Volume</b>	max	[cm <sup>3</sup> ]	37	40	60	115	170	360	690	1080
<b>Inertia</b>	①	[kgm <sup>2</sup> ]	0,0048	0,0116	0,0204	0,0564	0,1248	0,2697	0,516	1,166
<b>Inertia</b>	VAR 00	[kgm <sup>2</sup> ]	0,0046	0,0126	0,0219	0,0598	0,1165	0,2263	0,4320	0,950
<b>Inertia</b>	VAR 02	[kgm <sup>2</sup> ]	0,0046	0,0133	0,0215	0,0598	0,1165	0,2263	0,4320	0,950
<b>Weight</b>		[kg]	9	14	19,5	34,8	57	95	140	240
<b>Connection</b>			<b>Radial</b>							

Keyways according to  
ISO R773 / BS 4235 / DIN 6885-1 / NF E 22-175, tolerance P9

\* Mandatory delivered with finished bores

\*\*Drive cup is supplied undrilled. Fixing holes are shown for information only.

# P310 VAR 00 / VAR 10

## Pneumatic Toothed Clutch

### Characteristics

- Pneumatically operated
- Toothed clutch
- Functioning under pressure

### Utilisation

- Coupling of a pulley or a hub
- Engagement has to be made at standstill or at very low speed, in case of doubt consult the factory

### Particularities

- Positive coupling for drive without slipping
- Standard available for random or synchronised operation (one or more position(s)/rev) Multiposition/rev as option (VAR n0, "n" indicates number of positions)
- Option : detection disc allows the coupling position to be validated
- Stationary compressed air distribution included
- Sealed bearings

### Adjustments

- Verify position of tooth prior to installation
- No wear adjustment required

### Maintenance Manual

- SM 319

### Mounting Precautions

- The ball bearing life is a function of the speed and pressure, refer to curve shown (see diagramm)
- The anti-rotation device of the cylinder shall be inserted in anti rotation slot, with a side play of 0,5 mm and a 1 mm play to the bottom. This avoids a normal stress on the ball-bearings.
- It is forbidden to use in case of vibrations
- The customers mounting method must take into account the axial thrust
- Device intended for horizontal use, for vertical use please consult the factory

### Power Supply

- Oiled compressed air. For dry air please consult factory
- Can be operated with hydraulic oil. In that case, please consult the factory

Mounting Example

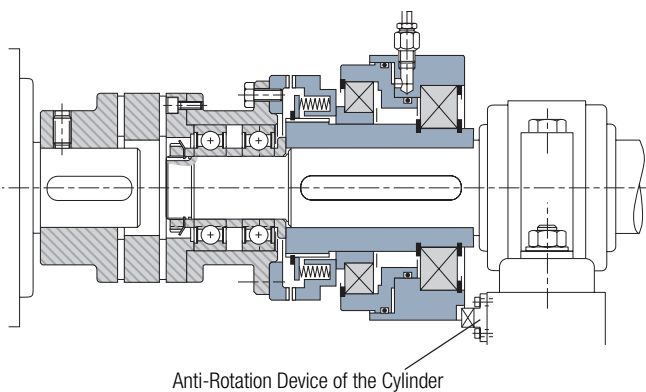

Ball Bearing Life for Nominal Pressure

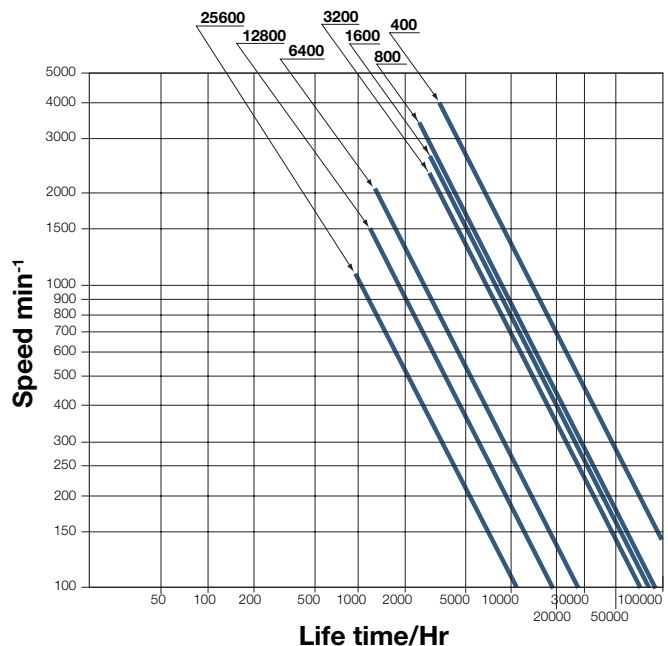

## Pneumatic Toothed Clutch

Size 100 - 3200\*

One slot in the axis of air supply hole

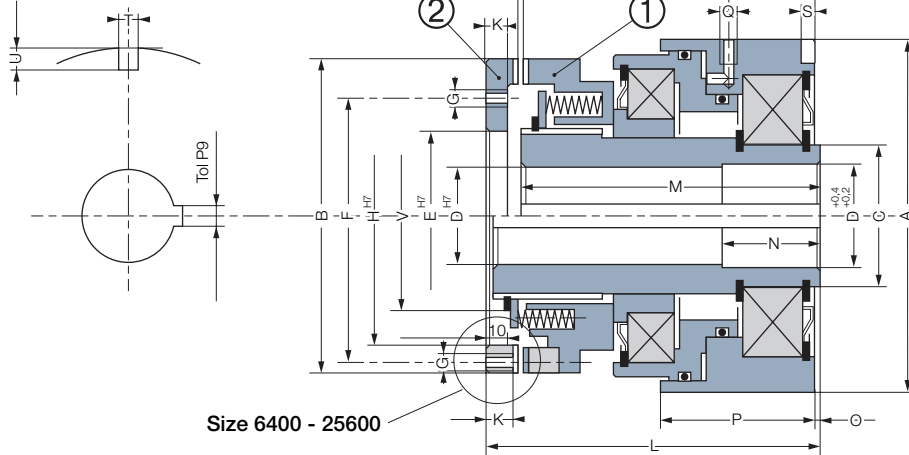

**Indirect  
Drive**

Sizes		100	200	400	800	1600	3200	6400	12800	25600
<b>Nom. Torque</b>	[Nm]	100	200	400	800	1600	3200	6400	12800	25600
<b>Max. Speed</b>	[min. <sup>-1</sup> ]	4300	3600	3300	2700	2100	1800	1450	1200	1000
<b>Operating Pressure</b>	[bar]	5	5	5	5	5	5	5	5	5
	A	118	132	149	166	198	234	270	324	398
	B	105	115	115	140	185	215	265	320	385
	C	50	55	65	80	95	110	130	150	180
	D* min	25	25	35	35	40	40	50	65	80
	D* max	35	40	50	60	75	90	105	120	140
	E min	45	50	50	65	105	110	-	-	-
	E max	70	80	80	95	130	155	-	-	-
	F**	82	92	92	110	148	175	240	290	355
	G**	4xM6	4xM6	8xM6	8xM8	8xM10	8xM12	12xM12	12xM14	12xM16
	H	0,5	0,6	0,6	0,6	0,6	0,8	0,8	0,8	0,9
	J	6	6	6	7	8	12	15	18	24
	K	98	110	114	128	158	195	215	255	315
	L	89,5	101	105	118	147	180	210	250	310
	M	89,5	101	105	118	147	180	210	250	310
	N	30	30	35	38	52	62	80	80	92
	O	-	-	-	0,5	3	5	5	5	10
	P	52	62	64	69,5	86	104	118	129	144
	Q	Rp1/8	Rp1/8	Rp1/8	Rp1/4	Rp1/4	Rp1/4	Rp3/8	Rp3/8	Rp3/8
	R	30	35	37	41	52	63	70	77	83
	S	5,5	5,5	4,5	6	7,5	8,5	8,5	9	12
	T	8	8	8	10	12	12	16	16	20
	U	12	12	12,5	11	11	14	17	23	22
	V	-	-	-	-	-	-	172	192	224
<b>Axial Load on Drive Cup 2</b>	[daN]	152	204	250	380	585	760	1270	2000	3100
<b>Stroke Volume</b>	max [cm <sup>3</sup> ]	7	11	12,5	19	27	48	90	155	280
<b>Inertia</b>	① [kgm <sup>2</sup> ]	0,0019	0,0032	0,0047	0,0114	0,0309	0,0770	0,1741	0,511	1,304
<b>Inertia</b>	② [kgm <sup>2</sup> ]	0,00073	0,0010	0,0010	0,0025	0,0095	0,0220	0,0364	0,091	0,252
<b>Weight</b>	[kg]	5,3	8	9,7	14	24	43	70	118	215
<b>Connection</b>		<b>Radial</b>								

Keyways according to ISO R773 / BS 4235 / DIN 6885-1 / NF E 22-175, tolerance P9

\* Mandatory delivered with finished bores

\*\* Drive cup is supplied undrilled for sizes 100 to 3200. Fixing holes are shown for information only

# H110 VAR 00

## Hydraulic Multi Disc Clutch

### Characteristics

- Hydraulically operated
- Multi disc
- Function under pressure

### Utilisation

- Coupling of a pulley or a hub

### Particularities

- For wet use
- Low residual torque
- Shaft driven
- Good graduality

### Adjustments

- None required, automatic wear compensation by piston movement

### Maintenance Manual

- SM 301

### Mounting Precautions

- Provide shaft seals in order to avoid loss of pressure (see ST 0119-01)
- Device intended for horizontal use; for vertical use, please consult the factory

### Power Supply

- Filtered oil

Mounting Example

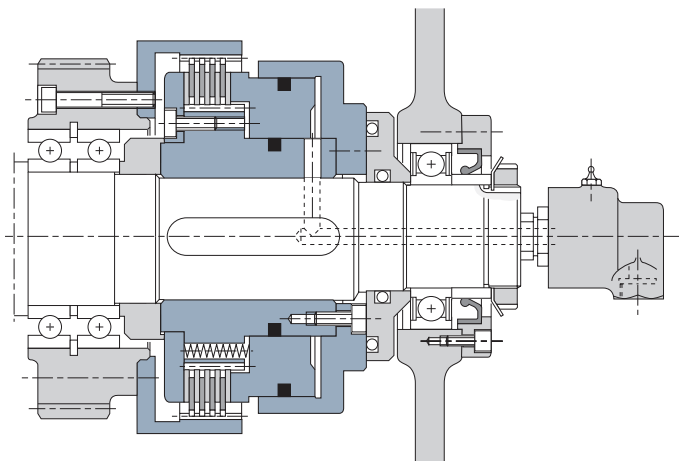

Heat Dissipation

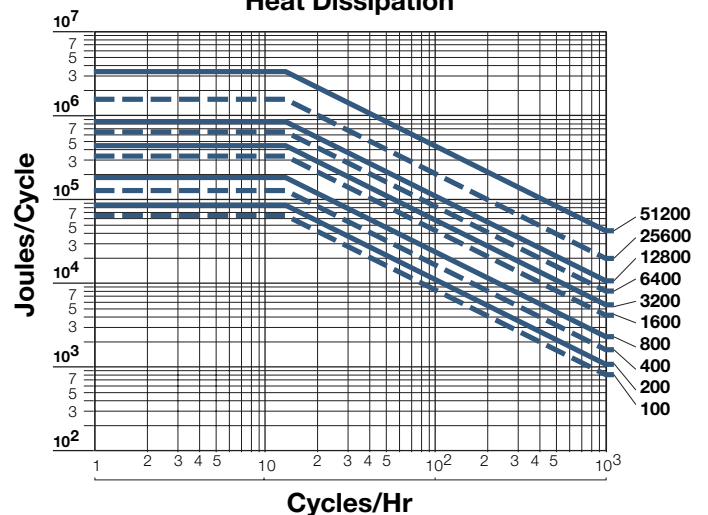

## Hydraulic Multi Disc Clutch

**Indirect Drive**

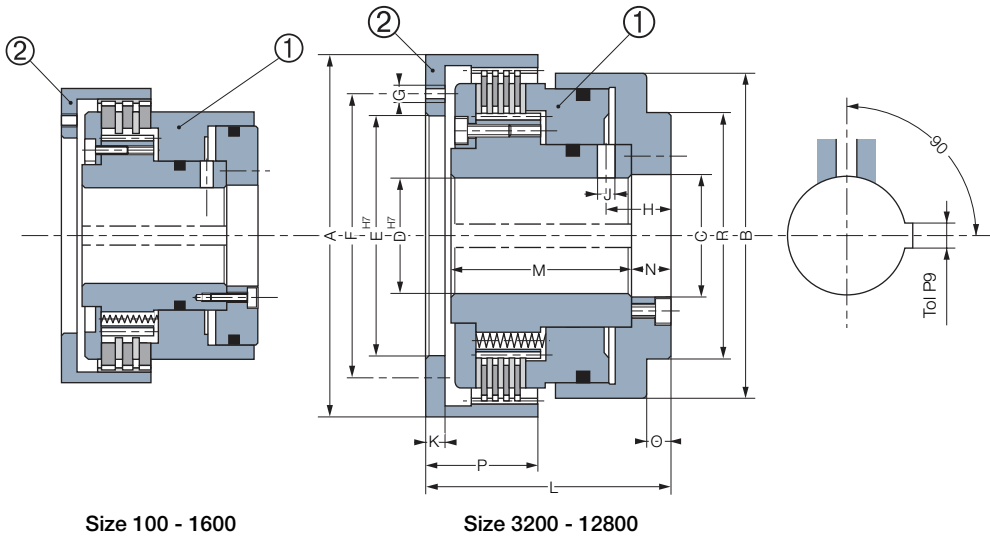

Size 100 - 1600

Size 3200 - 12800

Sizes		100	200	400	800	1600	3200	6400	12800	25600	51200
<b>Nom. Dynamic Torque</b>	[Nm]	100	200	400	800	1600	3200	6400	12800	25600	51200
<b>Nom. Static Torque</b>	[Nm]	150	300	600	1200	2500	5100	10200	20400	40900	81900
<b>Max. Speed</b>	[min <sup>-1</sup> ]	3600	2900	2700	2000	1800	1500	1300	1,200	1,000	900
<b>Operating Pressure</b>	[bar]	10	8	8	10	10	10	10	16	16	16
A		132	162	180	222	255	290	335	390	510	640
B		110	135	150	189	220	262	315	340	440	525
C		41	51	59	86	101	106	111	132	203	223
D* min		24	34	34	39	39	50	60	70	80	100
D* max		40	50	58	85	100	105	110	130	200	220
E min		50	64	69	86	101	120	130	180	240	330
E max		85	105	115	150	175	220	260	280	380	500
F**		100	122	135	170	200	250	290	320	420	540
G**		6xM6	6xM8	6xM8	6xM10	6xM12	6xM16	8xM16	12xM16	16xM16	16xM20
H		19	23	23	26	30,5	60	31	39	45	50
J		5	6	6	6	8	8	10	12	12	15
K		6	9	8	11	10	14	16	18	20	25
L		81	89	96	118	135	155	170	190	235	290
M		63,5	68	75	92	105	120	130	145	185	230
N		9,5	11	11	13	16	18	21	23	26	30
O		-	-	-	-	-	8	8	-	-	-
P		39	41	46	58	70	82	95	108	140	170
R		-	-	-	-	-	200	220	-	-	-
<b>Stroke Volume</b>	new [cm <sup>3</sup> ]	11,4	20	28	43	57	153	159	267	400	786
<b>Stroke Volume</b>	max [cm <sup>3</sup> ]	22	43	60	91	150	320	650	690	1170	2300
<b>Inertia</b>	① [kgm <sup>2</sup> ]	0,0061	0,0122	0,0253	0,0835	0,1818	0,3900	0,7700	1,37	5,14	14,67
	② [kgm <sup>2</sup> ]	0,0046	0,0126	0,0219	0,0598	0,1090	0,1828	0,3557	0,93	3,16	10,83
<b>Weight</b>	[kg]	5,3	8,5	11,5	22,2	35	55	87	124	262	510
<b>Connection</b>		Via Shaft									

Keyways according to ISO R773 / BS 4235 / DIN 6885-1 / NF E 22-175, tolerance P9

\* Mandatory delivered with finished bores.

\*\* Drive cup is supplied undrilled. Fixing holes are shown for information only.

# L310 VAR 02

## Mechanical Multi Disc Torque Limiter

### Characteristics

- Torque limiter
- Multi disc
- Activated by spring pressure

### Utilisation

- Periodic or transitory overload limitation

### Particularities

- VAR 02  
For use in lubricated environments

### Adjustments

- Adjustment of slip moment by screw settings
- To anticipate an adjustment in case of wear

### Maintenance Manual

- SM 313

### Mounting Precautions

- Define slipping time to meet heat dissipation capabilities
- Device intended for horizontal or vertical use

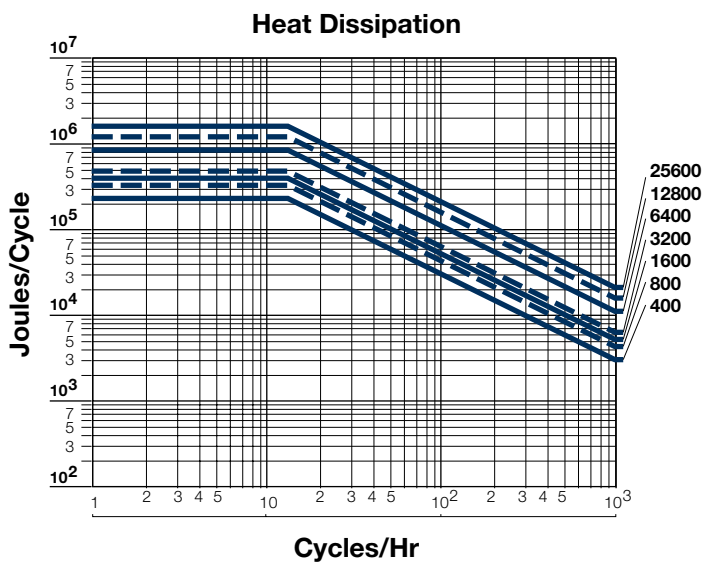

## Mechanical Multi Disc Torque Limiter

**Indirect  
Drive**

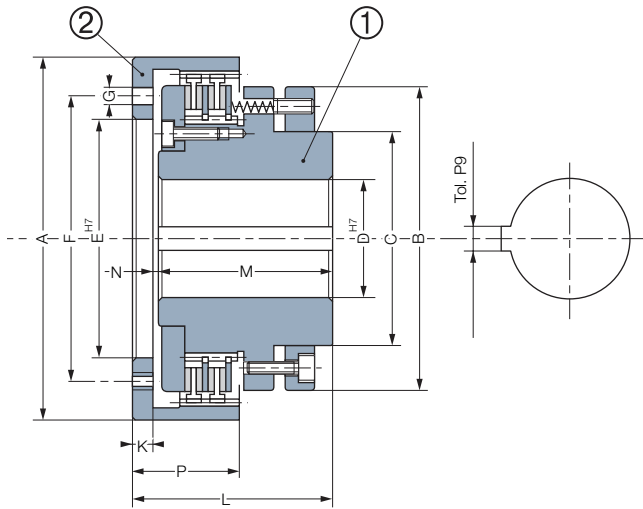

Sizes		400	800	1600	3200	6400	12800	25600
<b>Nom. Torque</b>	[Nm]	400	800	1600	3200	6400	12800	25600
<b>Max. Speed</b>	[min <sup>-1</sup> ]	2000	1700	1500	1300	1200	1000	900
	A	222	255	290	335	390	455	510
	B	190	222	252	293	338	398	452
	C	135	172	202	222	265	300	350
	D* min	30	40	40	80	100	120	150
	D* max	70	85	110	140	160	180	220
	E min	86	101	120	130	180	200	240
	E max	150	175	210	260	280	320	380
	F**	170	200	235	290	320	360	420
	G**	6xM10	6xM12	6xM12	6xM16	8xM16	12xM16	16xM16
	K	11	10	14	16	18	18	20
	L	112	118	127	150	170	200	230
	M	97	102	103	130	148	178	206
	N	4	6	10	4	4	4	4
	P	58	70	82	95	108	130	140
<b>Inertia</b>	① [kgm <sup>2</sup> ]	0,066	0,130	0,250	0,508	1,05	2,34	4,48
<b>Inertia</b>	② [kgm <sup>2</sup> ]	0,021	0,063	0,106	0,482	0,95	2,20	3,28
<b>Weight</b>	[kg]	19	28,5	40	69	105	172	237

Keyways according to  
ISO R773 / BS 4235 / DIN 6885-1 / NF E 22-175, tolerance P9

\* Mandatory delivered with finished bores.

\*\* Drive cup is supplied undrilled. Fixing holes are shown for information only.

# L331 VAR 00

## Mechanical Multi Disc Torque Limiter

### Characteristics

- Monobloc torque limiter
- Multi disc
- Activated by spring pressure

### Utilisation

- Periodic or transitory overload limitation

### Particularities

- Encapsulated device, discs operate in oil

### Adjustments

- Adjustment of slip moment by screw settings
- To anticipate an adjustment in case of wear

### Maintenance Manual

- SM 314

### Mounting Precautions

- Define slipping time to meet heat dissipation capabilities
- Device intended for horizontal or vertical use

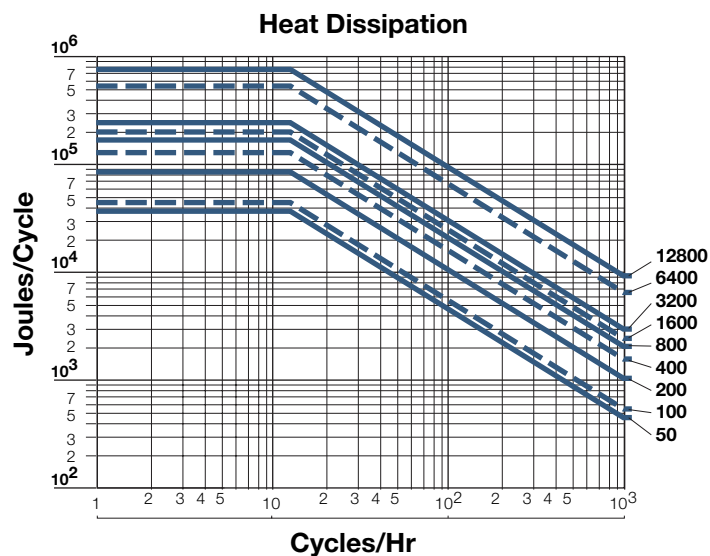



## Mechanical Multi Disc Torque Limiter

**Indirect  
Drive**

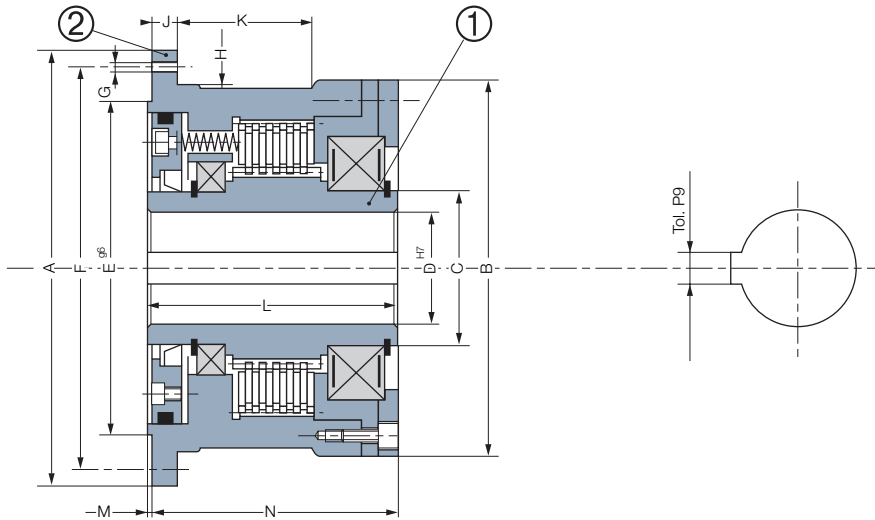

Sizes		50	100	200	400	800	1500	3200	6400	12800
<b>Nom. Torque</b>	[Nm]	50	100	200	400	800	1600	3200	6400	12800
<b>Max. Speed</b>	[min <sup>-1</sup> ]	4800	3800	3200	2700	2200	1900	1600	1300	1000
A		130	165	165	180	206	250	250	318	450
B		115	125	135	150	180	200	232	295	375
C		40	50	60	70	85	100	120	150	180
D* min		18	20	25	30	30	45	50	80	100
D* max		30	36	48	55	65	80	95	120	140
E		95	120	120	135	160	200	200	255	370
F		115	145	145	160	185	225	225	290	410
G For Screws		6xM8	8xM10	8xM10	10xM10	10xM12	12xM12	12xM12	12xM16	16xM20
H		101,5	127,5	127,5	142,5	165,5	205,5	205,5	265,5	379
J		5	9	9	9	20	17	17	19	35
K		31	-	41	48	54	-	75	100	-
L		65	70	80	95	110	135	160	195	230
M		1	1	1	1	1,5	1,5	1,5	2	2,5
N		64	69	79	94	108,5	133,5	158,5	193	227,5
<b>Inertia</b>	① [kgm <sup>2</sup> ]	0,0005	0,0010	0,0021	0,0034	0,0103	0,0215	0,043	0,140	0,442
<b>Inertia</b>	② [kgm <sup>2</sup> ]	0,0064	0,013	0,0173	0,0284	0,0632	0,1589	0,228	0,740	3,026
<b>Weight</b>	[kg]	4,2	5,8	7,3	10,1	16,2	28,4	37,4	75	162

Keyways according to  
ISO R773 / BS 4235 / DIN 6885-1 / NF E 22-175, tolerance P9  
\* Mandatory delivered with finished bores

# L331 VAR 05

## Mechanical Multi Disc Torque Limiter

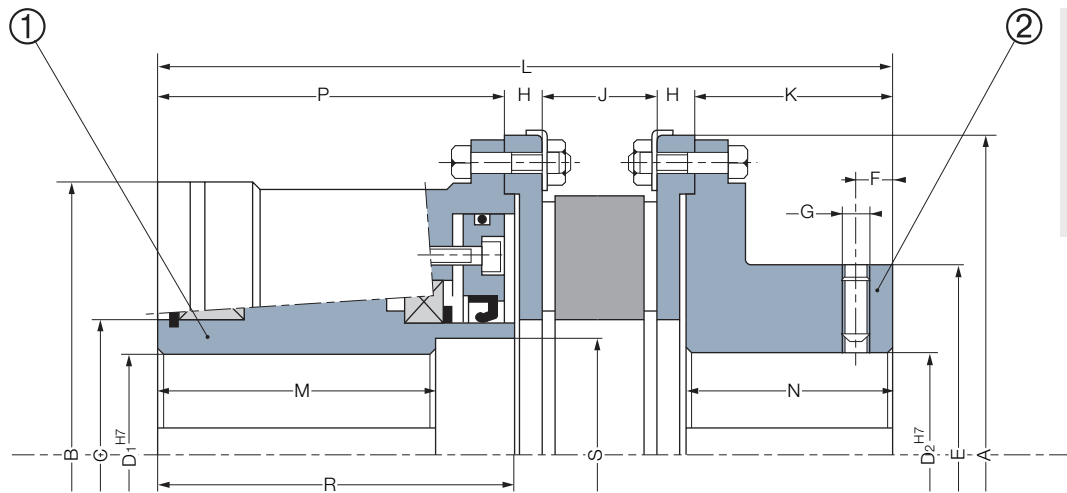

**Direct Drive  
with Elastic  
Coupling**

Sizes		50	100	200	400	800	1500	3200	6400	12800	
<b>Rotex Coupling</b>		42	55	55	65	75	90	90	110	160	
	A	140	175	175	190	215	260	260	330	460	
	B	115	125	135	150	180	200	232	295	375	
	C	40	50	60	70	85	100	120	150	180	
	D1* min	18	20	25	30	30	45	50	80	100	
	D1* max	30	36	48	55	65	80	95	120	140	
	D2* min	18	20	25	30	30	45	50	60	80	
	D2* max	42	55	55	65	75	90	90	125	185	
	E	75	98	98	115	135	160	160	200	290	
	F	10	20	20	20	20	30	30	30	40	
	G	M8	M10	M10	M10	M10	M12	M12	M12	M16	
	H	12	16	16	16	19	20	20	26	38	
	J	26	30	30	35	40	45	45	55	75	
	K	50	65	65	75	85,5	99,5	99,5	120	174,5	
	L	164	196	206	236	272	318	343	420	553	
	M	55	55	60	72	85	107	132	167	200	
	N	51	66	66	76	87	101	101	122	177	
	P	64	69	79	94	108,5	133,5	158,5	193	227,5	
	R	65	70	80	95	110	135	160	195	230	
	S	33	41	53	60	71	86	101	126	150	
<b>Inertia</b>		[kgm <sup>2</sup> ]	0,0005	0,0010	0,0021	0,0034	0,0103	0,0215	0,043	0,140	0,442
<b>Inertia</b>	①	[kgm <sup>2</sup> ]	0,0178	0,0472	0,0523	0,0837	0,1596	0,3832	0,463	1,521	6,632
<b>Weight</b>	②	[kg]	9,62	16,3	18,1	24,4	36,8	61,4	71,4	142	344

### Maintenance Manual

- SM 314

Keyways according to  
ISO R773 / BS 4235 / DIN 6885-1 / NF E 22-175, tolerance P9

\* Mandatory delivered with finished bores



# PBM VAR 00

## Electro-Magnetic Single Disc Brake

### Characteristics

- Electrically operated 12, 24, 103,5 VDC
- Single friction face
- Activated by power on

### Utilisation

- Braking or maintaining a pulley or a hub

### Particularities

- No backlash
- For dry use
- No residual torque in disengaged position

### Adjustments

- Airgap "P" should be adjusted at installation
- Requires wear compensation

### Maintenance Manual

- SM 304

### Mounting Precautions

- Centre the inductor
- Device intended for horizontal or vertical use

### Power Supply

- For 24 volts versions only :  
CBC 400-24, CBC 450-24  
CBC 500-24, CBC 550-24  
CBC 700 (overexcitation)  
CBC 140-5 + CBC 140-T (24V)  
CBC 140-5 (103,5V)

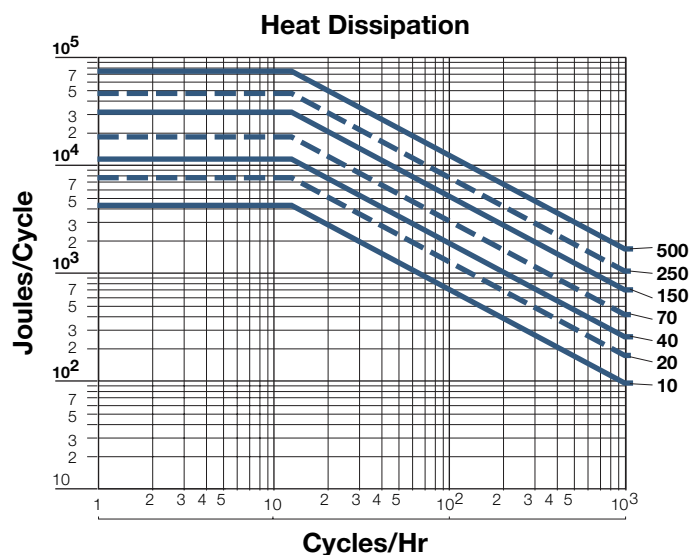

## Electro-Magnetic Single Disc Brake

**EUROstandard  
Indirect Drive**

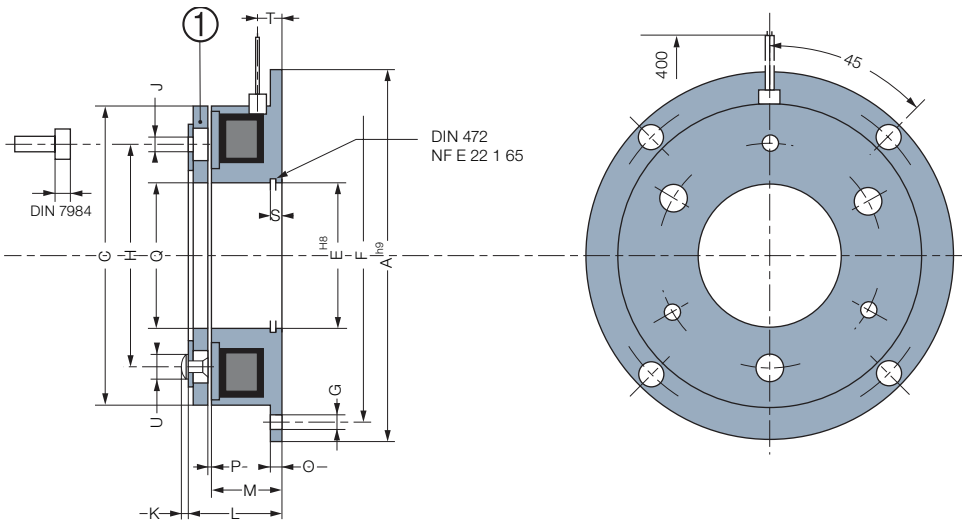

Sizes		10	20	40	70	150	250	500
<b>Nom. Torque</b>	[Nm]	7	15	30	60	120	250	500
<b>Max. Speed</b>	[min.⁻¹]	8000	6000	5000	4000	3000	2500	2000
<b>Power</b>	P20 [12/24/103,5V] [W]	9	16,5	21	24	30	43	58
	A	80	100	125	150	190	230	290
	C	63	81	100	125	160	200	250
	E	35	41	52	62	80	100	125
	F	72	90	112	137	175	215	270
	G For Screw	4xM4	4xM5	4xM6	4xM6	4xM8	4xM8	4xM10
	H	46	60	76	95	120	158	210
	J For Screw	3xM3	3xM4	3xM5	3xM6	3xM8	3xM10	4xM12
	K	1	1,5	2	2,5	3	3	5
	L	22	24,5	28	31	35	41,5	48,3
	M	18	20	22	24	26	30	35
	O	2	2,5	3	3,5	4	5	6
	P	0,2	0,2	0,3	0,3	0,3	0,5	0,5
	Q	35	42	52	62	80	100	125
	S	3,5	4,3	5	5,5	6	7	8
	T	6	6,5	9	9,5	10,5	12	12
	U	6	6	10	12	12	17	20
<b>Inertia</b>	[kgm²]	0,00004	0,00012	0,0005	0,0013	0,0049	0,0140	0,0360
<b>Weight</b>	[kg]	0,3	0,5	0,95	1,7	3,3	5,9	11,5
<b>Connection</b>		<b>Leads</b>			<b>Cable</b>			

### Connector Options

(Delivered without cable)

2 poles, capacity : 0,5/2,5mm²

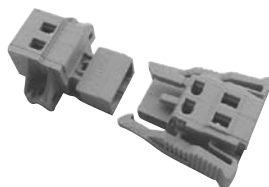

(1)- Fixing "J" on mobile armature by mean of screws DIN 7984 (not provided)

# PBM VAR 01

## Electro-Magnetic Single Disc Brake

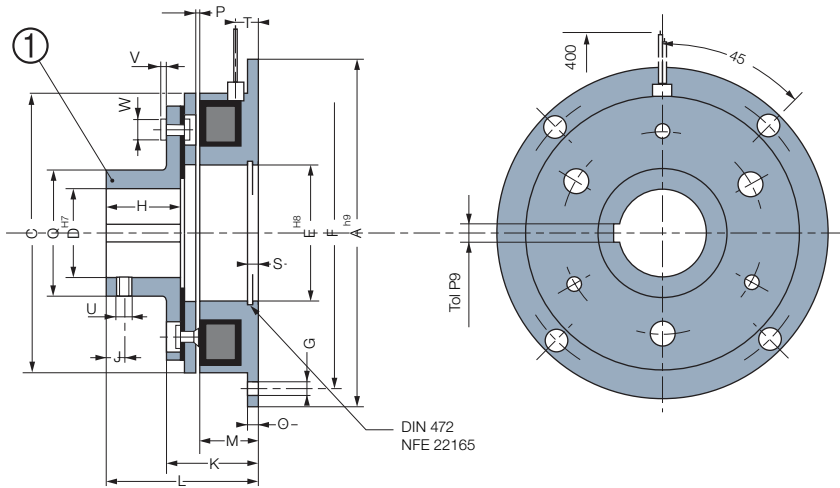

**EUROstandard  
Direct Drive**

Sizes		10	20	40	70	150	250	500	
Nom. Torque	[Nm]	7	15	30	60	120	250	500	
Max. Speed	[min.]	8,000	6,000	5000	4000	3000	2500	2000	
Power	P20 [12/24/103,5V]	[W]	9	16,5	21	24	30	43	58
	A		80	100	125	150	190	230	290
	C		63	81	100	125	160	200	250
	D min		10H8	10H8	14H8	14H7	20H7	25H7	25H7
	D std		10/15/17	10/17/20	20/25/30	25/30/35	30/40/45	40/50/60	50/60/80
	D max		17H8	20H8	30H8	35H7	45H7	60H7	80H7
	E		35	42	52	62	80	100	125
	F		72	90	112	137	175	215	270
	G For Screw		4xM4	4xM5	4xM6	4xM6	4xM8	4xM8	4xM10
	H		15	20	25	30	38	48	55
	J		5	6	6	10	10	15	20
	K		25,5	28,5	33	37	42	52,3	62,3
	L		37	44,5	53	61	73	89,5	103,5
	M		18	20	22	24	26	30	35
	O		2	2,5	3	3,5	4	5	6
	P		0,2	0,2	0,3	0,3	0,3	0,5	0,5
	Q		27	32	42	49	65	83	105
	S		3,5	4,3	5	5,5	6	7	8
	T		6	6,5	9	9,5	10,5	12	12
	U		M4	M4	M4	M6	M8	M10	M10
	V		1,5	2	2,5	3	4	1,5	2,5
	W		6	8	10	12	16	20	24
Inertia	① [kgm <sup>2</sup> ]		0,00006	0,00021	0,00079	0,0020	0,0077	0,0242	0,0705
Weight	[kg]		0,4	0,7	1,32	2,32	4,8	9	17,6
Connection			Leads			Cable			

### Connector Options

(Delivered without cable)

2 poles, capacity : 0,5/2,5mm<sup>2</sup>

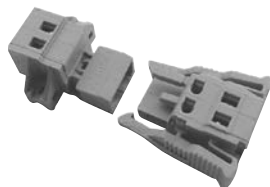

Keyways according to  
ISO/R 773 / BS 4235 / DIN 6885-1 / NF E 22-175, tolerance P9

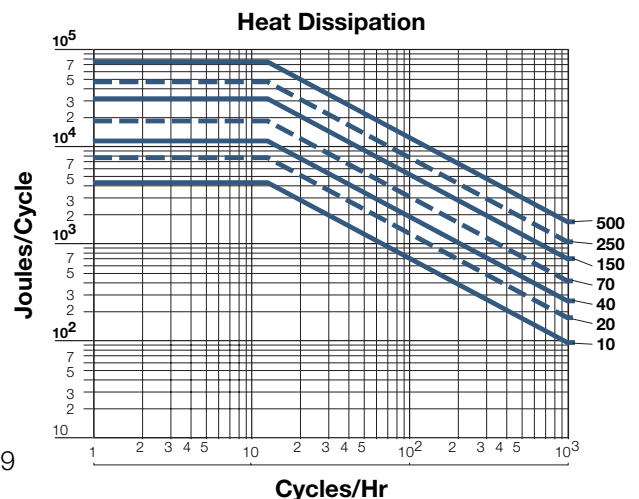



# E510 VAR 00

## Electro-Magnetic Single Disc Brake

### Characteristics

- Electrically operated 24 or 103,5 VDC depending size
- Single friction face
- Activated by power on

### Utilisation

- Braking or holding of a shaft

### Particularities

- No Backlash
- For dry use
- No residual torque in disengaged position

### Adjustments

- Airgap "P" should be adjusted at installation
- Does not require wear compensation

### Maintenance Manual

- SM 315

### Mounting Precautions

- Device intended for horizontal or vertical use

### Power Supply

- For sizes until 1600 :  
CBC 400-24, CBC 450-24  
CBC 500-24, CBC 550-24  
CBC 140-5 + CBC 140-T (24V)
- For size 3200 :  
CBC 140-5 (103,5V)

Mounting Example

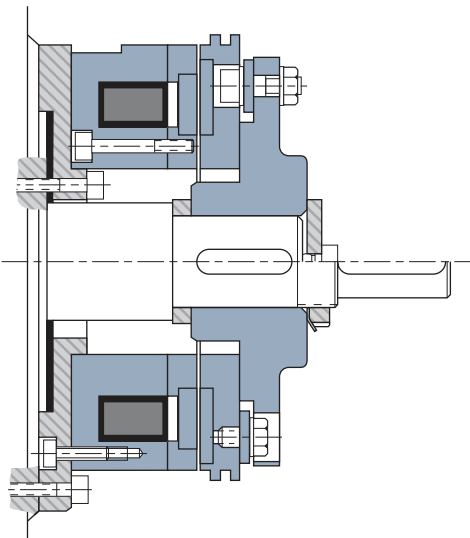

Heat Dissipation

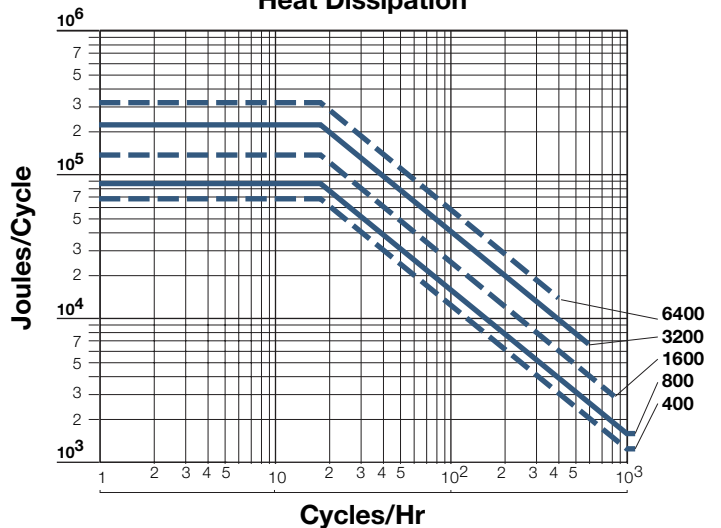



## Electro-Magnetic Single Disc Brake

**Direct Drive**

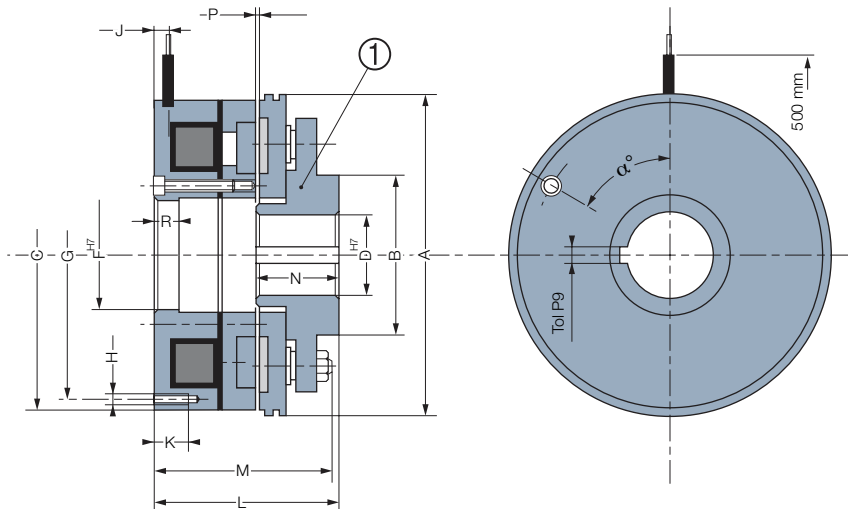

Sizes			400	800	1600	3200	6400
<b>Nom. Torque</b>		[Nm]	400	800	1600	3200	6400
<b>Max. Speed</b>		[min.]	2000	1700	1500	1500	1500
<b>Voltage</b>		[VDC]	24	24	24	103,5	103,5
<b>Power</b>	P20	[W]	29	36	59	89	121
	A		260	300	360	450	560
	B		100	120	140	175	230
	C		260	300	360	450	560
	D min		35	40	50	65	80
	D max		70	80	100	110	150
	E		-	-	-	-	-
	F		110	125	150	195	265
	G		225	265	320	400	500
	H		4xM8	4xM10	4xM12	6xM12	6xM16
	J		7	7	10	10	10
	K		20	20	25	25	30
	L		90	105	120	141	161
	M		95	110	128	146,5	166,5
	N		46	54	60	100	118
	P		0,5	0,6	0,8	0,8	1
	Q		-	-	-	-	-
	R		30	30	30	30	30
	α°		45°	45°	45°	30°	30°
<b>Inertia</b>	1	[kgm²]	0,0342	0,0736	0,2042	0,681	1,975
<b>Weight</b>		[kg]	18,1	30	51	105	190
<b>Connection</b>	<b>Cable</b>						

### Connector Options

(Delivered without cable)

2 poles, capacity : 0,5/2,5mm²

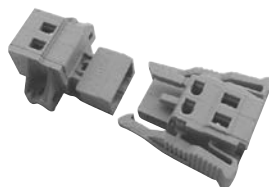

Keyways according to  
ISO/R 773 / BS 4235 / DIN 6885-1 / NF E 22-175, tolerance P9

# E520 VAR 00

## Electro-Magnetic Single Disc Brake

### Characteristics

- Electrically operated 24 or 103,5 VDC depending on size
- Single friction face
- Activated by power on

### Utilisation

- Braking or maintaining a pulley or a hub

### Particularities

- No backlash
- For dry use
- No residual torque in disengaged position

### Adjustments

- Airgap "P" should be adjusted at installation
- Does not require wear compensation

### Maintenance Manual

- SM 315

### Mounting Precautions

- Device intended for horizontal or vertical use

### Power Supply

- For sizes until 1600 :  
CBC 400-24, CBC 450-24  
CBC 500-24, CBC 550-24  
CBC 140-5 + CBC 140-T (24V)
- For size 3200 :  
CBC 140-5 (103,5V)

Mounting Example

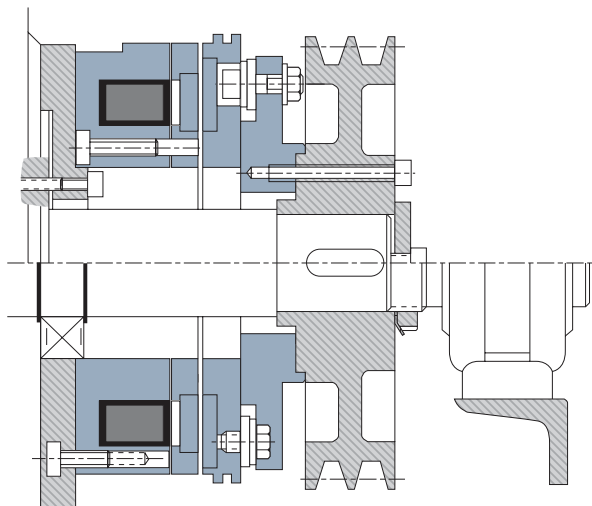

Heat Dissipation

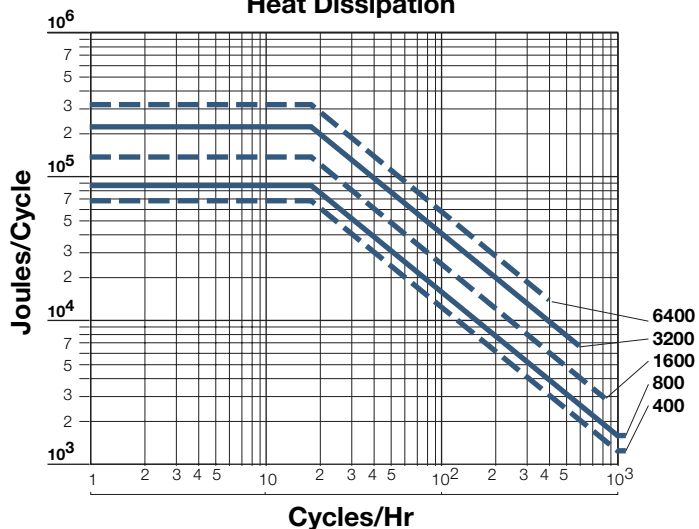

## Electro-Magnetic Single Disc Brake

**Indirect Drive**

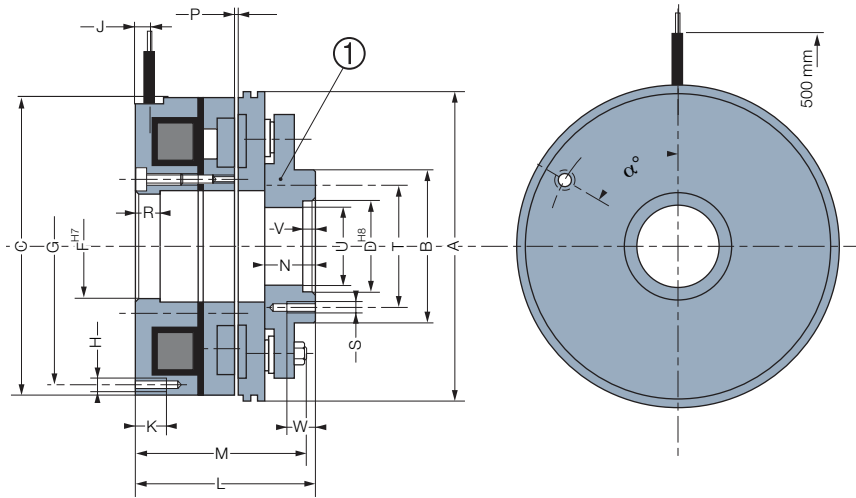

Sizes		400	800	1600	3200	6400
<b>Nom. Torque</b>	[Nm]	400	800	1600	3200	6400
<b>Max. Speed</b>	[min.]	2000	1700	1500	1500	1500
<b>Voltage</b>	[VDC]	24	24	24	103,5	103,5
<b>Power</b>	P20 [W]	29	36	59	89	121
	A	260	300	360	450	560
	B	140	155	180	220	295
	C	260	300	360	450	560
	D	100	115	140	150	180
	E	-	-	-	-	-
	F	110	125	150	195	265
	G	225	265	320	400	500
	H	4xM8	4xM10	4xM12	6xM12	6xM16
	J	7	7	10	10	10
	K	20	20	25	25	30
	L	114	131	152	172	198
	M	95	110	128	146,5	166,5
	N	41	49	55	60,4	71,2
	P	0,5	0,6	0,8	0,8	1
	Q	-	-	-	-	-
	R	30	30	30	30	30
	S	6xM8	6xM10	8xM12	8xM12	8xM16
	T	120	135	160	195	260
	U	90	106	126	135	160
	V	5	5	6	7	8
	W	14	15	18	20	25
	$\alpha^\circ$	45°	45°	45°	30°	30°
<b>Inertia</b>	<b>1</b> [kgm <sup>2</sup> ]	0,0342	0,0736	0,2042	0,681	1,975
<b>Weight</b>	[kg]	17,5	29	50	95	173
<b>Connection</b>	<b>Cable</b>					

### Connector Options

(Delivered without cable)

2 poles, capacity : 0,5/2,5mm<sup>2</sup>

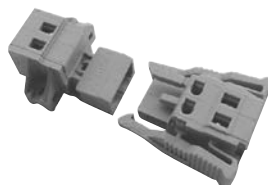

# ERD VAR 00 / VAR 02 005-300

## Electro-Magnetic Electro Release Brake

### Characteristics

- Electrically operated 24, 103,5 or 207 VDC
- Single disc
- Activated by spring pressure

### Utilisation

- Braking a shaft
- Holding a load

### Particularities

- For dry use
- No residual torque in disengaged position

### Adjustments

- Factory set, no adjustment required
- With wear adjustment for dynamic use

### Maintenance Manual

- SM 321A for sizes 005 to 035
- SM 321 for sizes 060 to 300

### Mounting Precautions

- For horizontal or vertical use for standard versions
- Horizontal use for high torque versions
- Release shipping screws after mounting

### Power Supply

- CBC 140-5 + CBC 140-T (24V)
- CBC 140-5 (103,5V - 207V)

### Response Times

Response times are average values for switching on the DC side. Pull-in = release time for 10 % torque left. Drop-out = time to obtain 90 % torque. DC side operated, AC side operated t x 6 (typ)

Switch time on the DC side

Sizes		005	010	020	035	060	100	170	300
Pull-in	[ms]	36	54	45	104	188	195	297	354
Drop-out	[ms]	18	26	29	45	47	74	99	160

### Mounting Example



### Heat Dissipation

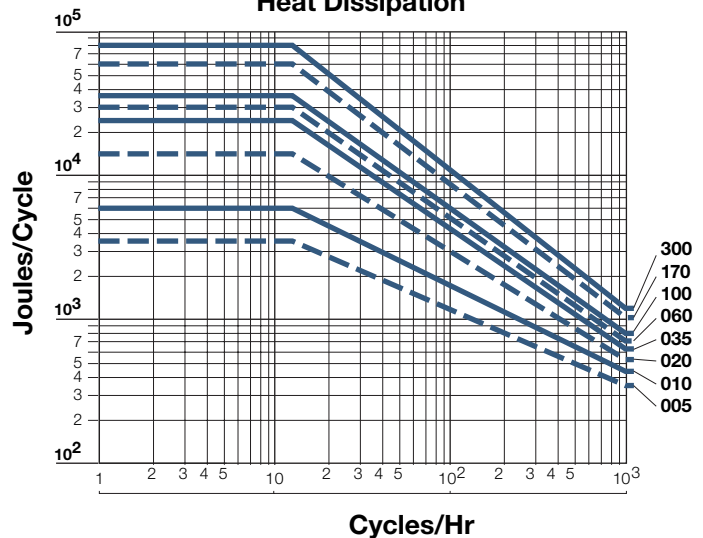

## Electro-Magnetic Electro Release Brake

### VAR 00

### VAR 02

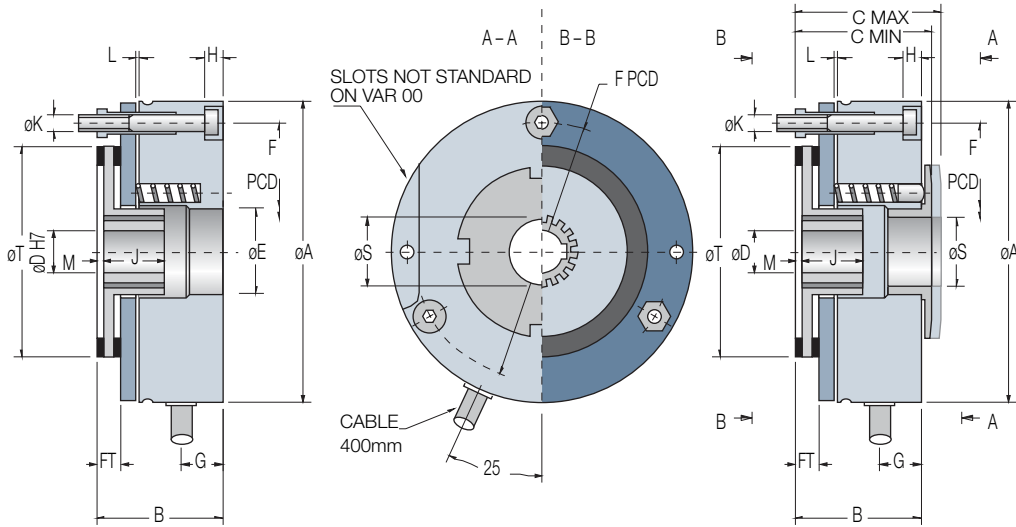

### Microswitch Option

- Kit for sizes 060 to 300 only.

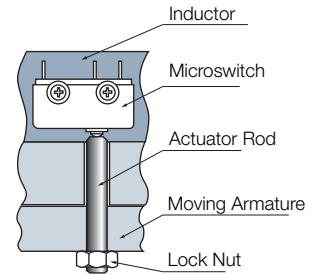

Sizes		005	010	020	035	060	100	170	300	
<b>STANDARD</b>										
Nom. Torque	[Nm]	5	10	20	35	60	100	170	300	
Max. Speed	[min. <sup>-1</sup> ]	3600	3600	3600	3600	3600	3600	3600	3600	
<b>HI-TORK</b>										
Nom. Torque	[Nm]	–	–	–	–	80	130	220	400	
Max. Speed	[min. <sup>-1</sup> ]	–	–	–	–	2600	2300	1900	1600	
Power	P24 VCD	20	25	30	39	47	57	66	99	
	P20 103,5 VCD	23	27	33	43	55	66	76	128	
	207 VCD	23	27	33	43	62	86	84	135	
	A	84	102	127	147	162	188	215	252	
	B	35	41	47,5	54,5	64	71	83	97	
	C min	38,5	44,5	52	61	70	77	89	107	
	C max	40	46,5	55,5	65	74,5	81,5	96	115	
	D pre-bore	8	10	10	14	14	15	20	25	
	D standard H7	10/11	10/14/15*	15/20/22/24*	20/24/25	25/30	25/30/35	35/40/45	35/40/45	
	D max*	12*	15*	24*	28*	32*	40*	50*	54*	
	E	23,5	28,5	40,5	48,5	58,5	63,5	73,5	88,5	
	F	72	90	112	132	145	170	196	230	
	FT	6,5	8,2	9,8	11	12	12	14,7	15,7	
	G	11,7	14,6	15,5	19,7	19	22	27	34	
	H	5,1	6,4	5,8	7,3	8,7	11	13	18	
	J	0/+0,2	18	20	20	25	30	35	40	
	K	3xM4	3xM5	3xM6	3xM6	3xM8	3xM8	6xM8	6xM10	
	L nom	0,2	0,2	0,2	0,3	0,3	0,3	0,3	0,3	
	M synth	1,5	2,5	–	–	–	–	–	–	
	M metal	2	3	4	3	3	3	4,5	5	
	S	19	24	35	40	48	52	60	73	
	T	60	77	96	116	125	150	174	204	
Inertia	Synthetic	[kgcm <sup>2</sup> ]	0,12	0,5	–	–	–	–	–	
	STD Metal	[kgcm <sup>2</sup> ]	0,271	0,70	2,30	7,465	6,3	14,4	29	61
Inertia	HT	[kgcm <sup>2</sup> ]	–	–	–	–	8,5	20,5	47	92
Weight	[kg]	0,9	1,7	3	4,6	6,4	9,9	15,6	25,9	
Connection		<b>Cable</b>								

The HT torque outlined is a static torque: for dynamic applications, please contact our technical department.

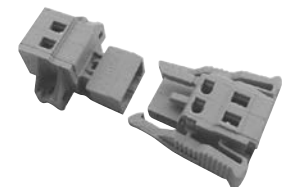

### Connector Options

(Delivered without cable)  
2 poles, capacity :  
0,5/2,5mm<sup>2</sup>

Keyways according to  
ISO/R 773 / BS 4235 / DIN 6885-1 / NF E 22-175, tolerance P9  
\*Keyways according to DIN 6885-1/3

# ERD VAR 00 / VAR 02 005-300

## Electro-Magnetic Single Disc Electro Release Brake

### Hand Release

Designed to be retrofitted, except VAR 00.

Automatically returns to “neutral position” when released, thereby restoring holding torque to the brake.

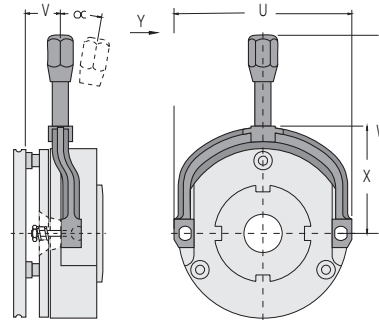

Sizes	005	010	020	035	060	100	170	300
U	88	106	132	152	166	187	223	262,5
V	17	18	25	22	40	44	53	61
W	98	107	129	139	189	205	240	313
X	53	62	76	86	104	120	140	162
Y [N]	30	53	62	107	150	200	250	450
α [°]	10	9	8	8	15	15	15	20

### Friction Flanges for Brake Mounting

Sizes	ERD005	ERD010	ERD020	ERD035	ERD060	ERD100	ERD170	ERD300
AA	87	107	132,5	152,5	—	—	—	—
BB	42	54	60	70	—	—	—	—
CC (min)	3,2	3,2	3,6	4,6	—	—	—	—
DD	83	100	125	145	160	185	212	250
EE	6	7	9	9	11	11	11	11
F	K 3 x M4 HH 3 x 4,5	3 x M5 3 x 5,5	3 x M6 3 x 6,5	3 x M6 3 x 6,5	3 x M8 3 x 8,3	3 x M8 3 x 8,3	6 x M8 6 x 8,3	6 x M10 6 x 10,3
FF	20	30	40	45	55	65	75	90
GG	30	45	56	62	74	84	100	120
KK	8	10	11	11	14	14	14	17
LL	2	2	3	3	3	3	3	3
MM	35	40	50	55	63	68	77	87,5
NN	40	45	55	60	—	—	—	—

### Intermediate Flange

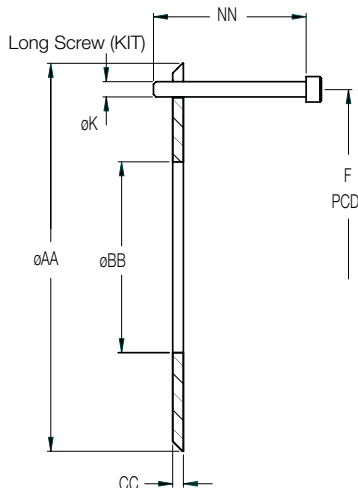

### Thick Flange

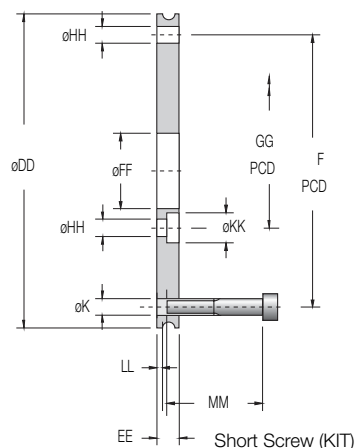

### Dust Cover Option

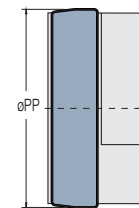

Sizes	005	010	020	035
PP [mm]	88	106	132	152



Sizes	060	100	170	300
PP [mm]	166	192	219	256

# ERD VAR 00 / VAR 02 005-300

## Electro-Magnetic Single Disc Electro Release Brake

### Classification Key



\* Microswitch Only for VAR02

Nominal Torque $M_d$ [Nm]	300	 <b>M</b>	 <b>S</b>	 <b>HT</b>	**Special 207 VDC 103,5 VDC VDC	See page 73 00 Pre-bored [mm]	None <b>0</b> With <b>1</b>
	170						
	100						
	060						
	035						
	020						
	010						
	<b>005</b>						

  

Model	Size	Design	OPTION	Voltage VDC	Bore H7	
<b>E R D</b>	<b>0 0 5</b>	<b>2 0</b>	<b>M 1 2</b>	<b>0 2 4</b>	<b>1 1</b>	<b>0</b>

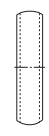
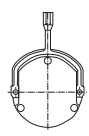

Cable <b>0</b> Cable + Connector 1 (Unmounted)	0 None 1 Dust Cover 2 Hand Release 3 1 + 2	  	
---	---	---	---

VAR 00		$M_d$ No Adjustment
VAR <b>02</b>		$M_d$ Central Adjustment

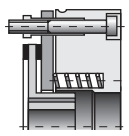
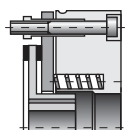
No Friction Flange		<b>0</b>
Intermediate Friction Flange (size 005-035 only)		<b>3</b>
Thick Friction Flange		<b>2</b>

\* Only for sizes 060 to 300

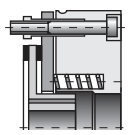
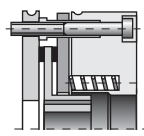
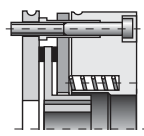
\*\* Min. 50 pieces

# ERD VAR 00 500-3200

## Electro-Magnetic Single Disc Electro Release Brake

### Characteristics

- Electrically operated 103,5 VDC
- Single disc
- Activated by spring pressure

### Utilisation

- Braking a shaft
- Holding a load

### Particularities

- For dry use
- No residual torque in disengaged position

### Adjustments

- Airgap should be adjusted at installation
- Requires wear compensation for dynamic applications

### Maintenance Manual

- SM 300

### Mounting Precautions

- Sizes 500 / 800 / 1600 :
- For horizontal or vertical use for standard versions
- Horizontal use for high torque versions (H)  
For other sizes horizontal use only
- Release shipping screws after mounting

### Power Supply

- CBC 140-5

### Response Times

Response times are average values for switching on the DC side. Pull-in = release time for 10 % torque left. Drop-out = time to obtain 90 % torque. DC side operated, AC side operated  $t \times 6$  (typ)

Switch time on the DC side

Sizes		500	800	1600	3200
Pull-in	[ms]	400	550	650	1200
Drop-out	[ms]	200	320	380	420

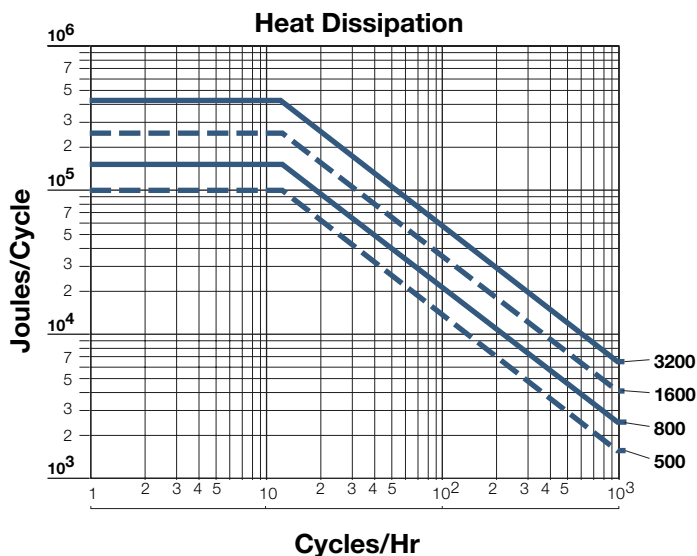



## Electro-Magnetic Single Disc Electro Release Brake

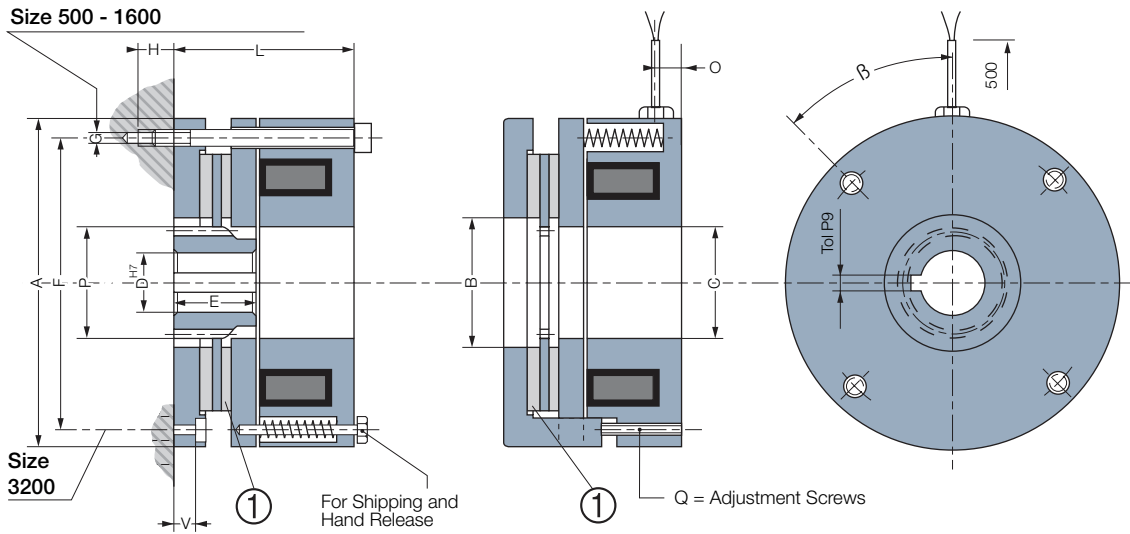

Sizes			500	800	1600	3200
<b>Nom. Torque</b>		[Nm]	500	800	1600	3200
<b>Max. Speed</b>		[min.]	3600	3000	2300	1800
<b>High Torque Version (HT)</b>		[Nm]	800	1100	2250	-
<b>Max. Speed at High Torque</b>		[min.]	650	500	400	-
<b>Voltage</b>		[VDC]	103,5	103,5	103,5	103,5
<b>Power</b>	P20	[W]	150	165	327	408
	A		265	320	395	500
	B		120	155	210	260
	C		98	124	168	210
	D min		30	35	50	60
	D max		65	80	110	125
	E		60	70	100	125
	F		240	294	360	455
	G		4xM12	4xM12	4xM16	8xM20
	H min		25	27	30	-
	L		122	136	165	205
	O		20	27	27	36
	Q		4xM12	4xM16	4xM16	4xM20
	V		-	-	-	40
	B		50°	45°	60°	22°30'
<b>Hub</b>	Pressure Angle	$\alpha^\circ$	20°	20°	20°	20°
	Number of Teeth	[Z]	37	39	53	63
	Module	[m]	2,5	3	3	3
	Diametrical Pitch	[Dp]	92,5	117	159	189
	Outside Diameter	[P]	95	120	162	195
	Dimension on K tooth		34,38	41,34	50,786	60,06
	K Tooth	[K]	5	5	6	7
<b>Inertia</b>	STD	[kgm <sup>2</sup> ]	0,0100	0,0282	0,0997	0,513
	HT		0,0156	0,0418	0,1379	-
<b>Weight</b>		[kg]	35	64	120	229
<b>Connection</b>			<b>Cable</b>			

The HT torque outlined is a static torque: for dynamic applications, please contact our technical department.

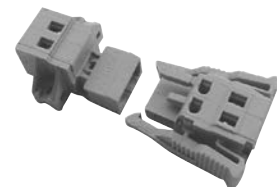

### Connector Options

(Delivered without cable)

2 poles, capacity : 0,5/2,5mm<sup>2</sup>

Keyways according to ISO/R 773 / BS 4235 / DIN 6885-1 / NF E 22-175, tolerance P9

# ERD VAR 03 500-12800

## Electro-Magnetic Single Disc Electro Release Brake

### Characteristics

- Electrically operated 103,5 VDC
- Single disc
- Activated by spring pressure

### Utilisation

- Braking a shaft
- Holding a load

### Particularities

- For dry use
- No residual torque in disengaged position
- For Tacho mounting
- Torque adjustment with screw cap until size 3000
- Option: detection kit and dust cover

### Adjustments

- Airgap should be adjusted at installation
- Requires wear compensation for dynamic applications

### Maintenance Manual

- SM 300

### Mounting Precautions

- Sizes 500 / 800 / 1600 :
- For horizontal or vertical use for standard versions
- Horizontal use for high torque versions (H)  
For other sizes horizontal use only
- Release shipping screws after mounting

### Power Supply

- CBC140-5 for sizes until 3200

### Response Times

Response times are average values for switching on the DC side.

Pull-in = release time for 10 % torque left.

Drop-out = time to obtain 90 % torque.

DC side operated, AC side operated  $t \times 6$  (typ)

Switch time  
on the DC side

Sizes		500	800	1600	3200	6400	12800
Pull-in	[ms]	400	550	650	1200	1800	2000
Drop-out	[ms]	200	320	380	420	950	1300

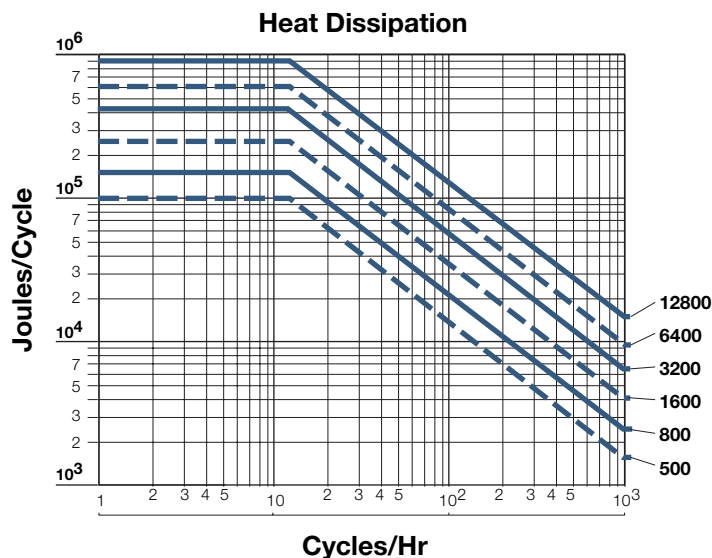

## Electro-Magnetic Single Disc Electro Release Brake

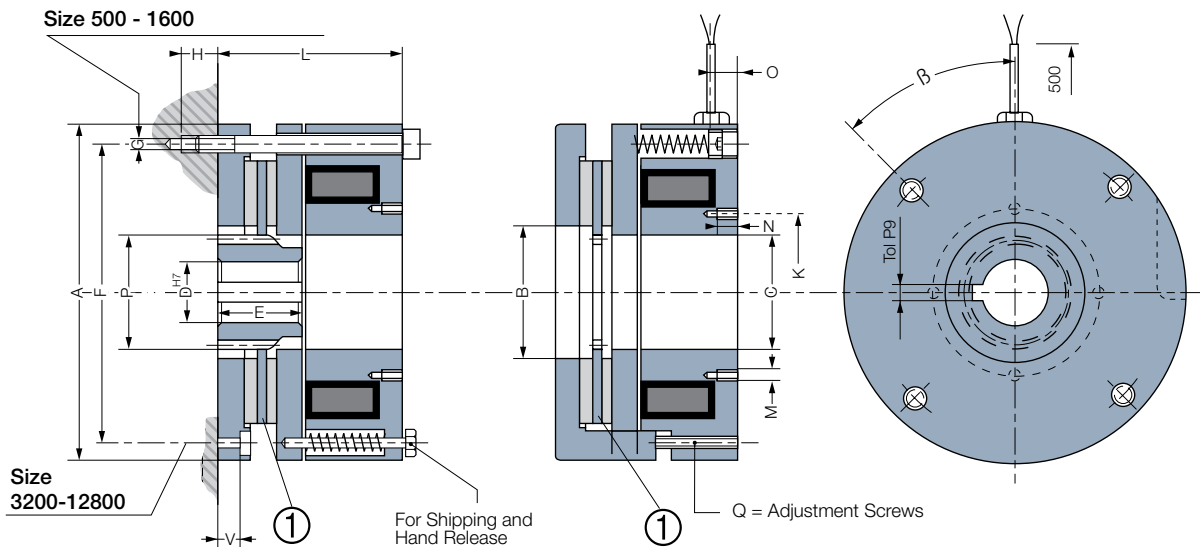

Sizes		500	800	1600	3200	6400*	12800*	
Nom. Torque	[Nm]	500	800	1600	3200	6400	12800	
Max. Speed	[min.]	3600	3000	2300	1800	1300	1200	
High Torque Version (HT)	[Nm]	800	1100	2200	-	-	-	
Max. Speed at High Torque	[min.]	650	500	400	-	-	-	
Voltage	[VDC]	103,5	103,5	103,5	103,5	103,5	103,5	
Power	P20 [W]	150	165	327	408	487	690	
	A	265	320	395	500	645	730	
	B	120	155	210	260	385	405	
	C	98	124	168	210	300	360	
	D min	30	35	50	60	75	100	
	D max	65	80	110	125	140	170	
	E	60	70	100	125	140	170	
	F	240	294	360	455	595	675	
	G	4xM12	4xM12	4xM16	8xM20	8xM24	8xM27	
	H min	25	27	30	-	-	-	
	K	126	150	216	250	358	430	
	L	122	136	165	205	245	290	
	M	4xM6	4xM6	4xM6	4xM6	4xM6	4xM6	
	N	12	12	12	15	15	15	
	O	20	27	27	36	40	50	
	Q	4xM12	4xM16	4xM16	4xM20	4xM24	4xM27	
	V	-	-	-	40	46	51	
	W	12	12	12	12	12	12	
	β	50°	45°	60°	22°30'	22°30'	22°30'	
Hub	Pressure Angle	α°	20°	20°	20°	20°	20°	
	Number of Teeth	[Z]	37	39	53	63	58	72
	Module	[m]	2,5	3	3	3	4	4
	Diametrical Pitch	[Dp]	92,5	117	159	189	232	288
	Outside Diameter	[P]	95	120	162	195	240	296
	Dimension on K tooth		34,38	41,34	50,786	60,06	79,80	92,39
	K Tooth	[K]	5	5	6	7	7	8
Inertia	STD	[kgm <sup>2</sup> ]	0,0100	0,0282	0,0997	0,513	1,664	2,96
	HT		0,0156	0,0418	0,1379	-	-	-
Weight		[kg]	35	64	120	229	426	671
Connection			Cable					

### Microswitch Option

- Indicate moving armature position

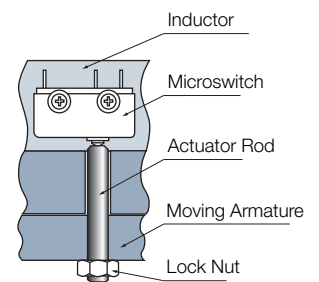

The HT torque outlined is a static torque: for dynamic applications, please contact our technical department.

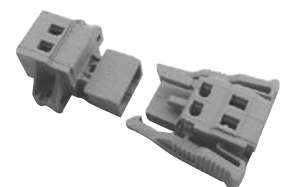

### Connector Options

(Delivered without cable)  
2 poles, capacity : 0,5/2,5mm<sup>2</sup>

Keyways according to ISO/R 773 / BS 4235 / DIN 6885-1 / NF E 22-175, tolerance P9  
\*Sizes 6400 and 12800, torque adjustment made by spring selection

# ERDD VAR 00 / VAR 02 120-6400

## Electro-Magnetic Dual Disc Electro Release Brake

### Characteristics

- Electrically operated 24 or 103,5 VDC, depending on size
- Dual disc
- Activated by spring pressure

### Utilisation

- Braking a shaft
- Holding a load

### Particularities

- For dry use
- No residual torque in disengaged position

### Adjustments

- Airgap should be adjusted at installation
- Requires wear compensation for dynamic applications

### Maintenance Manual

- SM 321 for sizes 120 to 600
- SM 300 for sizes 1000 to 6400

### Mounting Precautions

- For horizontal use only
- Release shipping screws after mounting

### Power Supply

- CBC 140-5

### Response Times

Response times are average values for switching on the DC side. Pull-in = release time for 10 % torque left. Drop-out = time to obtain 90 % torque.

DC side operated, AC side operated  $t \times 6$  (typ)

Switch time on the DC side

Sizes		120	200	340	600	1000	1600	3200	6400
Pull-in	[ms]	188	195	297	354	400	500	650	1200
Drop-out	[ms]	47	74	99	160	200	320	380	420

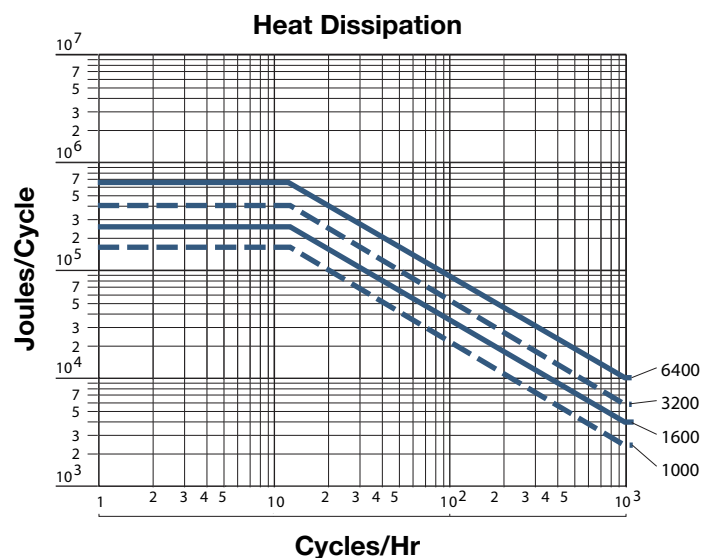
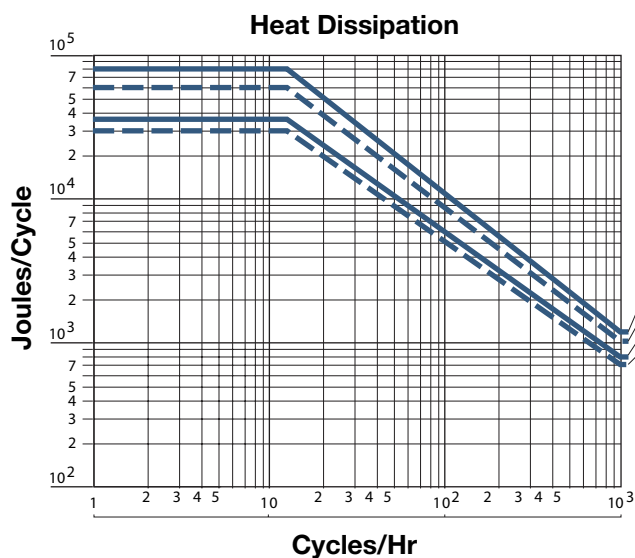

# ERDD VAR 00 / VAR 02 120-6400

## Electro-Magnetic Dual Disc Electro Release Brake

Size 120 - 600 VAR 02

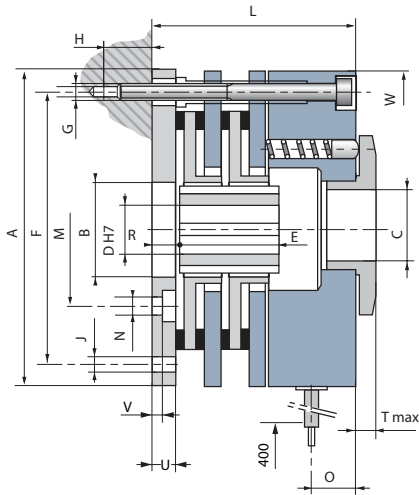

Size 1000 - 3200 VAR 00

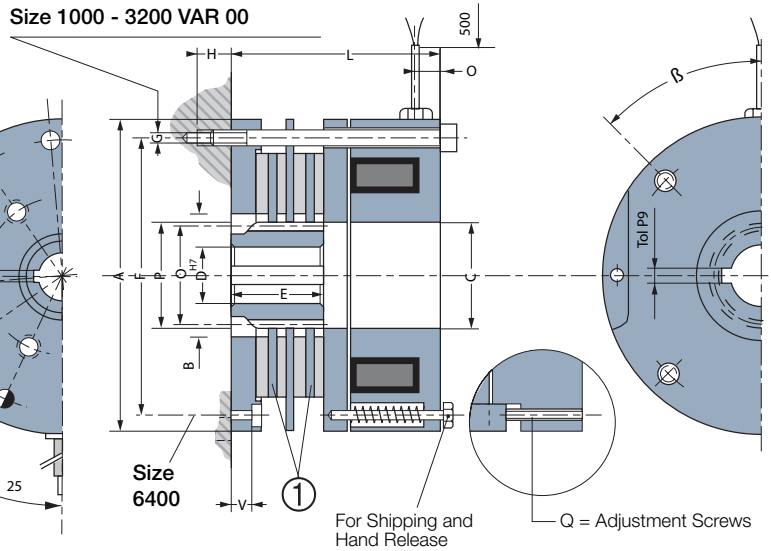

Sizes		120 VAR 02	200 VAR 02	340 VAR 02	600 VAR 02	1000 VAR 00	1600 VAR 00	3200 VAR 00	6400 VAR 00
Nom. Torque	[Nm]	-	-	-	600	1000	1600	3200	6400
Max. Speed	[min.-]	-	-	-	3600	3600	3000	2300	1800
High Torque Version (HT)	[Nm]	160	260	440	800	1600	2200	4500	-
Max. Speed at High Torque	[min.-]	2600	2300	1900	1600	650	500	400	-
Voltage	[VDC]	24	24	24	24	103,5	103,5	103,5	103,5
Power	P20 [W]	47	57	66	99	150	165	327	408
	A	160	185	212	250	265	320	395	500
	B	55	65	75	90	120	155	210	260
	C	48	52	60	73	98	124	168	210
	D pre-bored	14	15	20	25	30	35	50	60
	D min	25/30	25/30/35	35/40/45	35/40/45	-	-	-	-
	D max	32*	40*	50*	54*	65	80	110	125
	E	45	50	55	68	60	70	100	168
	F	145	170	196	230	240	294	360	455
	G	3xM8/120°	3xM8/120°	6xM8/60°	6xM10/60°	4xM12	4xM12	4xM16	8xM20
	H min	14	20	16	25	25	27	30	-
	J	8,3(3x120°)	8,3(3x120°)	8,3(6x60°)	10,3(6x60°)	-	-	-	-
	L	96	105	120	139	148	168	203	268
	M	74	84	100	120	-	-	-	-
	N	8,3(3x120°)	8,3(3x120°)	8,3(6x60°)	10,3(6x60°)	-	-	-	-
	O	19	22	27	34	20	27	27	36
	Q	-	-	-	-	4xM12	4xM16	4xM16	4xM20
	R	11	11	11	11	-	-	-	-
	Tmax	10,5	10,5	13	18	-	-	-	-
	U	11	11	11	11	-	-	-	-
	V	3	3	3	3	-	-	-	40
	W	162	188	215	252	-	-	-	-
	β	-	-	-	-	50°	45°	60°	22°30'
	[α°]	60°	60°	30°	30°	-	-	-	-
Hub	Pressure Angle	-	-	-	-	20°	20°	20°	20°
	Number of Teeth [Z]	-	-	-	-	37	39	53	63
	Module [m]	-	-	-	-	2,5	3	3	3
	Diametrical Pitch [Dp]	-	-	-	-	92,5	117	159	189
	Outside Diameter [P]	-	-	-	-	95	120	162	195
	Dimension on K tooth	-	-	-	-	5/34,38	5/41,34	6/50,786	7/60,06
Inertia	① STD	-	-	-	-	0,017	0,047	0,155	0,966
	HT	0,017	0,0040	0,0093	0,0181	0,0281	0,0742	0,1379	-
Weight	[kg]	8	12	20	30	38	72	133	292
Connection		Cable							

### Microswitch Option

- Indicate moving armature position. Not available for VAR 00

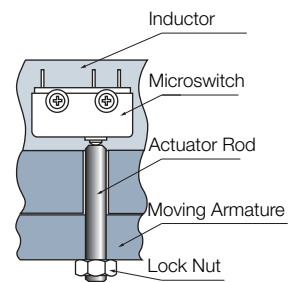

The HT torque outlined is a static torque: for dynamic applications, please contact our technical department.

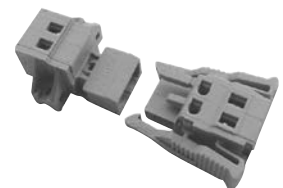

### Connector Options

(Delivered without cable)  
2 poles, capacity : 0,5/2,5mm<sup>2</sup>

Keyways according to ISO/R 773 / BS 4235 / DIN 6885-1 / NF E 22-175, tolerance P9

# ERDD VAR 03 1000-25600

## Electro-Magnetic Dual Disc Electro Release Brake

### Characteristics

- Electrically operated 103,5 VDC
- Dual disc
- Activated by spring pressure

### Utilisation

- Braking a shaft
- Holding a load

### Particularities

- For dry use
- No residual torque in disengaged position
- For Tacho mounting
- Torque adjustment with screw cap until size 6400
- Option: detection kit and dust cover

### Adjustments

- Airgap should be adjusted at installation
- Requires wear compensation for dynamic applications

### Maintenance Manual

- SM 300

### Mounting Precautions

- For horizontal use only
- Release shipping screws after mounting

### Power Supply

- CBC140-5 for sizes until 6400

### Response Times

Response times are average values for switching on the DC side. Pull-in = release time for 10 % torque left.

Drop-out = time to obtain 90 % torque.

DC side operated, AC side operated  $t \times 6$  (typ)

Switch time  
on the DC side

Sizes		1000	1600	3200	6400	12800	25600
Pull-in	[ms]	400	550	650	1200	1800	2000
Drop-out	[ms]	200	320	380	420	950	1300

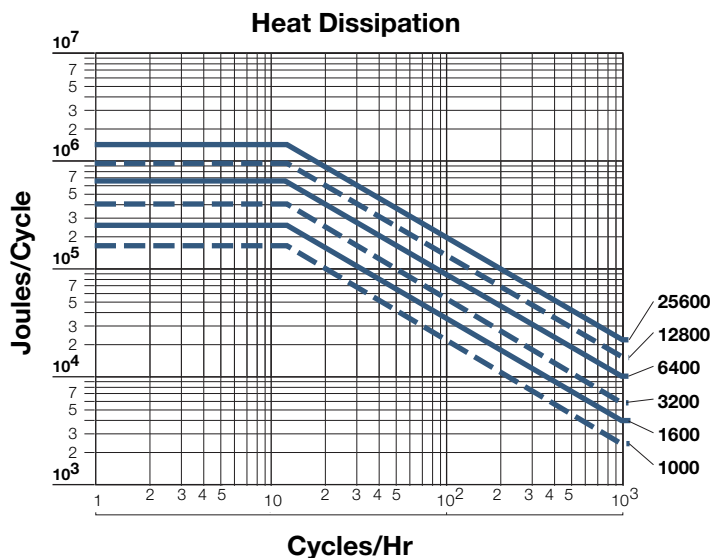

## Electro-Magnetic Dual Disc Electro Release Brake

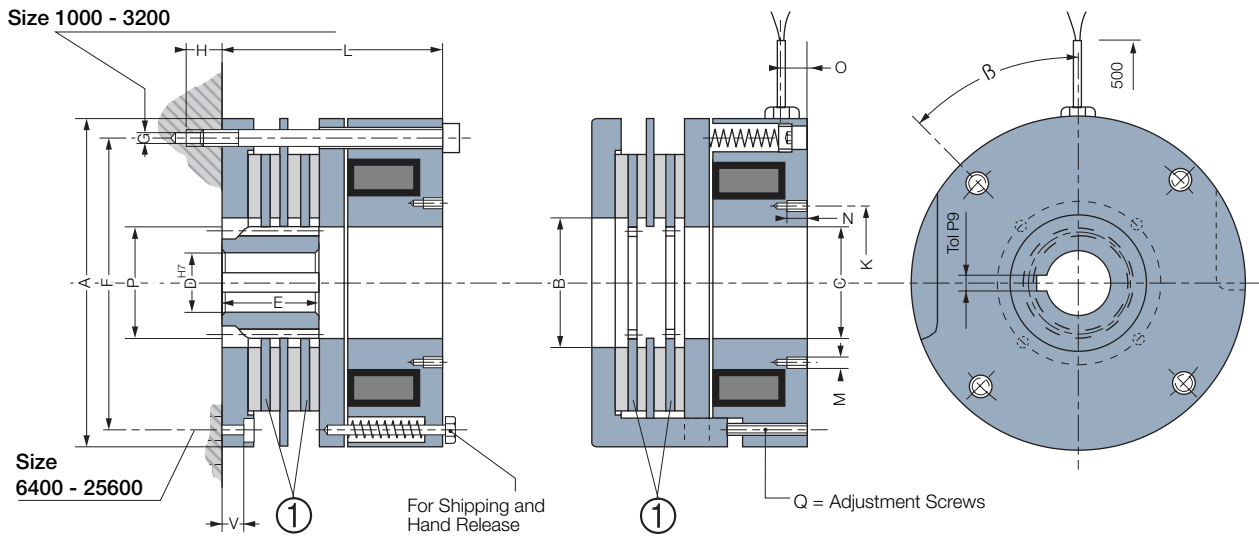

Sizes			1000	1600	3200	6400	12800*	25600*
Nom. Torque		[Nm]	1000	1600	3200	6400	12800	25600
Max. Speed		[min.-]	3600	3000	2300	1800	1300	1200
High Torque Version (HT)		[Nm]	1600	2200	4500	-	-	-
Max. Speed at High Torque		[min.-]	650	500	400	-	-	-
Voltage		[VDC]	103,5	103,5	103,5	103,5	103,5	103,5
Power	P20	[W]	150	165	327	408	487	690
	A		265	320	395	500	645	730
	B		120	155	210	260	385	405
	C		98	124	168	210	300	360
	D min		30	35	50	60	75	100
	D max		65	80	110	125	140	170
	E		60	70	100	125	140	170
	F		240	294	360	455	595	675
	G		4xM12	4xM12	4xM16	8xM20	8xM24	8xM27
	H min		25	27	30	-	-	-
	K		126	150	216	250	358	430
	L		148	168	203	268	310	365
	M		4xM6	4xM6	4xM6	4xM6	4xM6	4xM6
	N		12	12	12	15	15	15
	O		20	27	27	36	40	50
	Q		4xM12	4xM16	4xM16	4xM20	4xM24	4xM27
	V		-	-	-	40	46	51
	W		12	12	12	12	12	12
	$\beta$		50°	45°	60°	22°30'	22°30'	22°30'
Hub	Pressure Angle	$\alpha^\circ$	20°	20°	20°	20°	20°	20°
	Number of Teeth	[Z]	37	39	53	63	58	72
	Module	[m]	2,5	3	3	3	4	4
	Diametrical Pitch	[Dp]	92,5	117	159	189	232	288
	Outside Diameter	[P]	95	120	162	195	240	296
	Dimension on K tooth		34,38	41,34	50,786	60,06	79,80	92,39
	K Tooth	[K]	5	5	6	7	7	8
Inertia	①	[kgm <sup>2</sup> ]	0,013	0,038	0,125	0,954	2,87	5,27
Weight		[kg]	38	72	133	292	488	775
Connection			Cable					

### Microswitch Option

- Indicate moving armature position

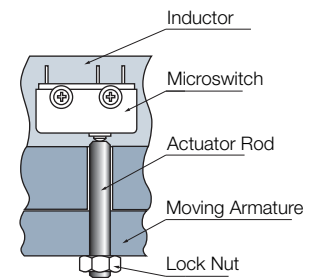

The HT torque outlined is a static torque: for dynamic applications, please contact our technical department.

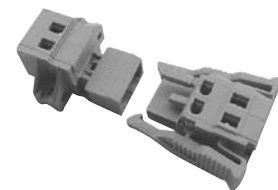

### Connector Options

(Delivered without cable)  
2 poles, capacity : 0,5/2,5mm<sup>2</sup>

Keyways according to  
ISO/R 773 / BS 4235 / DIN 6885-1 / NF E 22-175, tolerance P9  
\*Sizes 12800 and 25600, torque adjustment made by spring selection

# ERD-ERDD VAR 00 / VAR 03 120-25600

## Electro-Magnetic Dual Disc Electro Release Brake

### Options

#### Hand Release

Shipping screws may be used to release brake manually

**WARNING: see service manual**

Other solutions on request

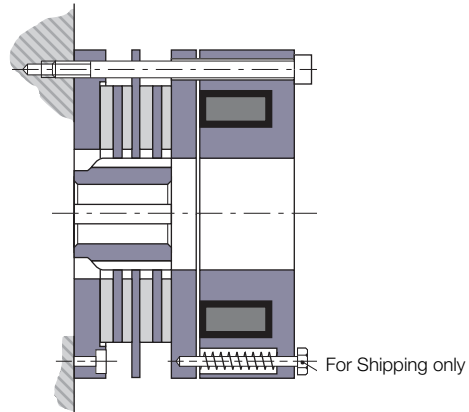

Sizes	ERD ERDD	500 1000	800 1600	1600 3200	3200 6400	6400 12800	12800 25600
Screws		2 x M10 x 80	4 x M12 x 90	3 x M16 x 110	8 x M20 x 120	8 x M20 x 140	8 x M20 x 180

#### Dustcover

Used to prevent entry of dust into the air gap or braking area. Also serves to limit the emission of dust from the same area.

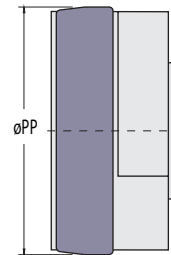

Sizes	ERD ERDD	500 1000	800 1600	1600 3200	3200 6400	6400 12800	12800 25600
ø PP (mm)		249	300	370	464	598	734

#### Silent Brakes

Available on request



# ERD-ERDD VAR 00 / VAR 03 120-25600

## Electro-Magnetic Single Disc Electro Release Brake

### How to Order

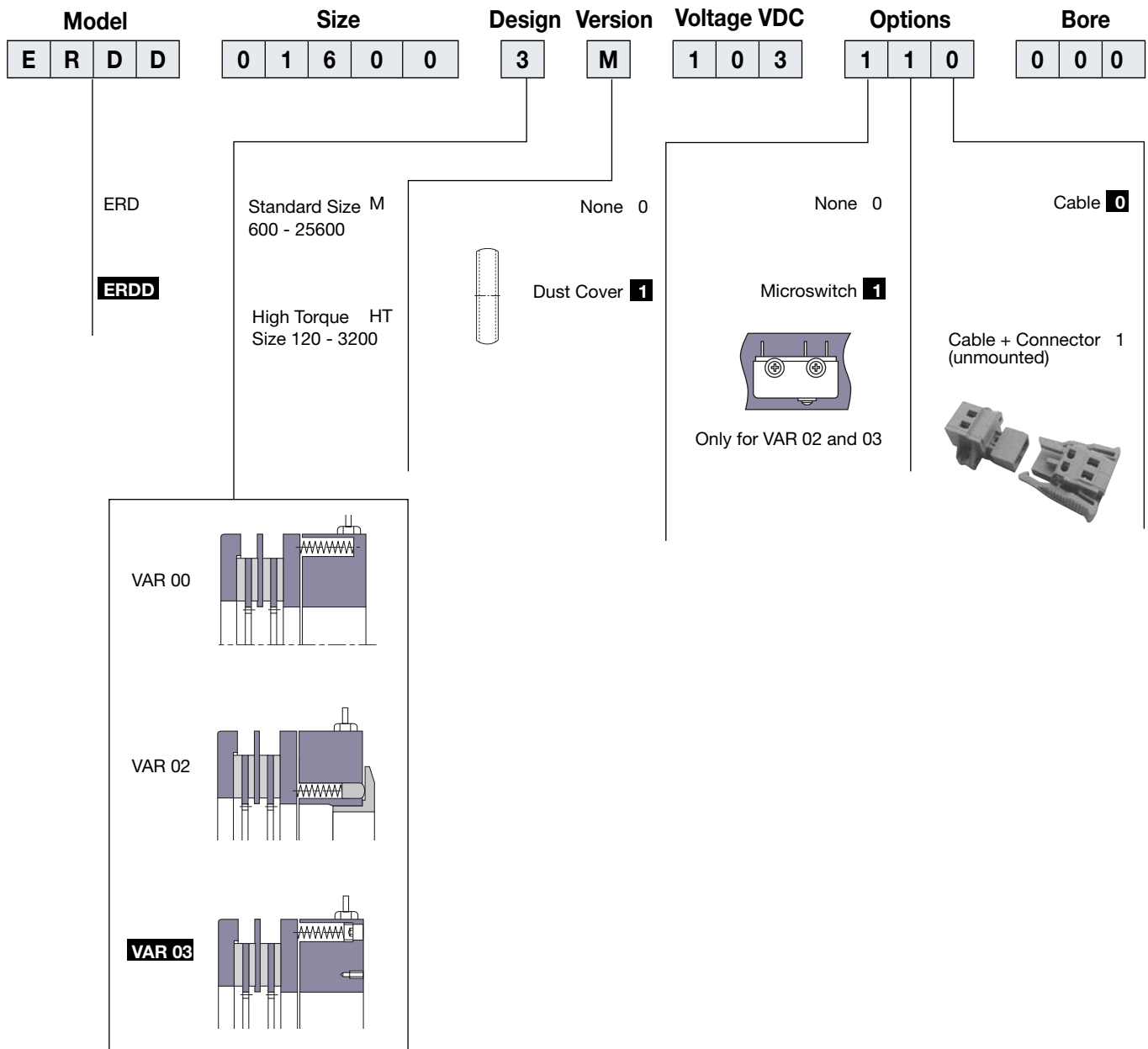
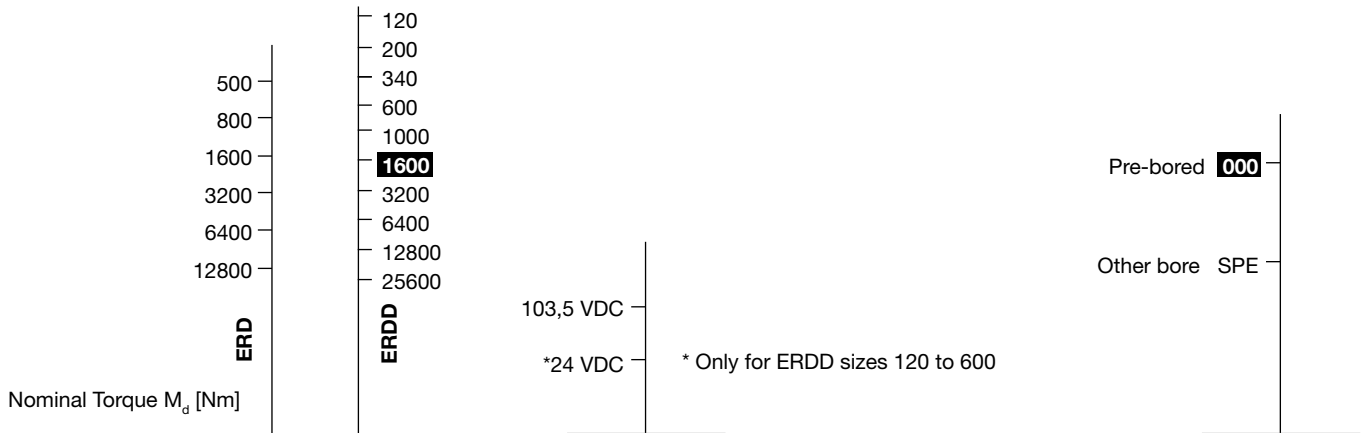

No VAR 00 for  
ERD 6400 / 12800  
ERDD 12800 / 25600

No VAR 02 for  
ERD 500 / 12800  
ERDD 1000 / 25600

# E710 VAR 00

## Electro-Magnetic Toothed Brake

### Characteristics

- Electrically operated 24 or 103,5 VDC, depending on size
- Toothed operated brake
- Activated by power on

### Utilisation

- Braking of a pulley or a hub in position
- Braking has to be made at standstill or at very low speed, in case of doubt consult the factory
- For wet or dry operation

### Particularities

- Positive braking for drive without slipping
- Standard available for random operation
- Option : detection disc allows the braking position to be validated, see dimensions page 47

### Adjustments

- Verify position of tooth "J" prior to installation
- No wear adjustment required

### Maintenance Manual

- SM 316

### Mounting Precautions

- Device intended for horizontal or vertical use

### Power Supply

- For sizes until 3200  
CBC 400-24, CBC 450-24,  
CBC 140 -5 + CBC 140-T (24V)
- For sizes 6400, and 12800  
CBC 140 -5 (103,5V)

### Mounting Example

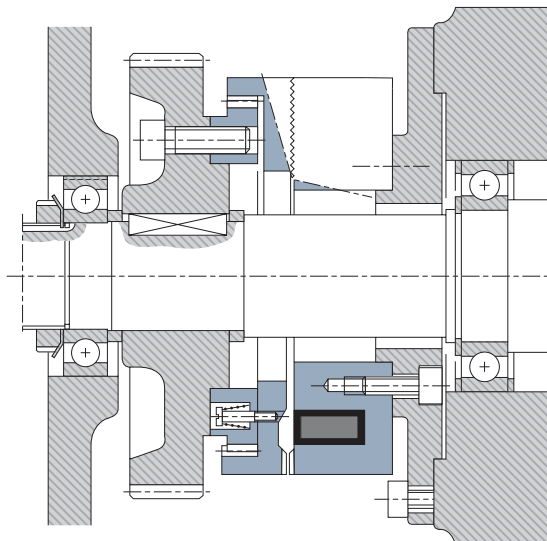

## Electro-Magnetic Toothed Brake

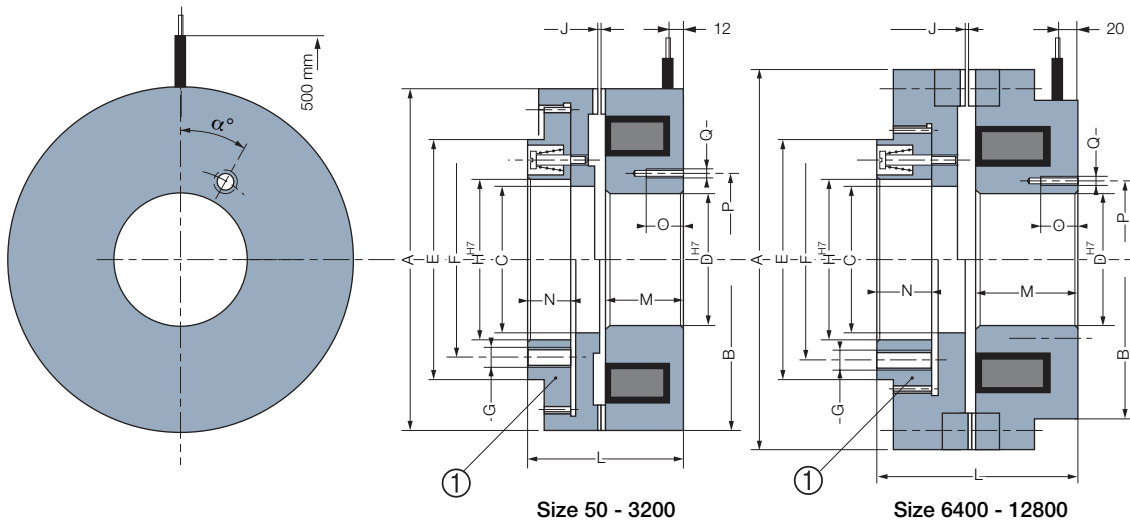

Sizes		50	100	200	400	800	1600	3200	6400	12800
<b>Nom. Torque</b>	[Nm]	50	100	200	400	800	1600	3200	6400	12800
<b>Max. Speed</b>	[min. <sup>-1</sup> ]	5000	4300	3600	3300	2700	2100	1800	1500	1500
<b>Voltage</b>	[VDC]	24	24	24	24	24	24	24	103,5	103,5
<b>Power</b>	P20 [W]	22	26	33	33	47	68	79	111	143
A		75	90	105	115	140	185	215	320	385
B		75	90	105	115	140	185	215	260	315
C		40	49,5	58	63	76	99	117	153	180
D		35	42	50	55	65	85	105	140	175
E		65,5	75,5	85,5	100,5	115,5	155,5	180,5	215,5	275,5
F		55	64	75	85	100	135	155	190	250
G		4xM5	4xM5	4xM6	6xM6	6xM8	6xM10	6xM10	12xM12	12xM116
H		45	53	65	70	85	115	130	153	190
J		0,4	0,5	0,5	0,5	0,6	0,7	0,9	1	1
L		38	40	44	48	65	80	100	143	165
M		23	22,3	23,7	26,2	36,9	44	52	82,3	92,6
N		8	10	12	12,5	17	21	28	35	41
O		9	9	10	13	17	19	20	26	30
P		45	50	65	70	80	110	135	170	210
Q		6xM5	6xM5	6xM6	6xM8	6xM10	6xM12	10xM12	10xM16	12xM18
α		30°	30°	30°	30°	30°	30°	18°	18°	15°
<b>Inertia</b>	① [kgm <sup>2</sup> ]	0,0002	0,0006	0,001	0,002	0,030	0,030	0,055	0,406	1,08
<b>Weight</b>	[kg]	0,8	1,25	1,8	2,5	5	11	22	54	90
<b>Connection</b>		<b>Leads</b>				<b>Cable</b>				

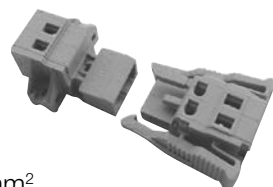

### Connector Options

(Delivered without cable)

2 poles, capacity : 0,5/2,5mm<sup>2</sup>

# E720 VAR 00

## Electro-Magnetic Toothed Brake

### Characteristics

- Electrically released - 103,5/48 VDC or 207/103,5 VDC, depending on size
- Toothed operated brake
- Activated by spring pressure

### Utilisation

- Braking of a pulley or a hub in position
- Braking has to be made at standstill or at very low speed, in case of doubt consult the factory
- For wet or dry operation

### Particularities

- This device works with two voltages: one for disengagement, one for position maintain
- Positive braking for drive without slipping
- Standard available for random operation
- Option : detection disc allows the braking position to be validated, see dimensions page 41

### Adjustments

- Verify position of tooth "Q" prior to installation
- No wear adjustment required

### Maintenance Manual

- SM 317

### Mounting Precautions

- Device intended for horizontal or vertical use
- The customers mounting method must take into account the axial thrust

### Power Supply CBC 140-5

- Overexcitation delay: 0,5 s (size 50) to 2 s (size 12800)

### Mounting Example

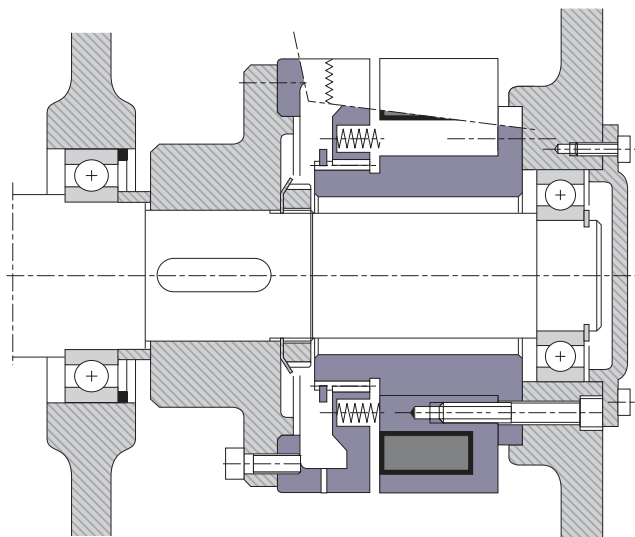

## Electro-Magnetic Toothed Brake

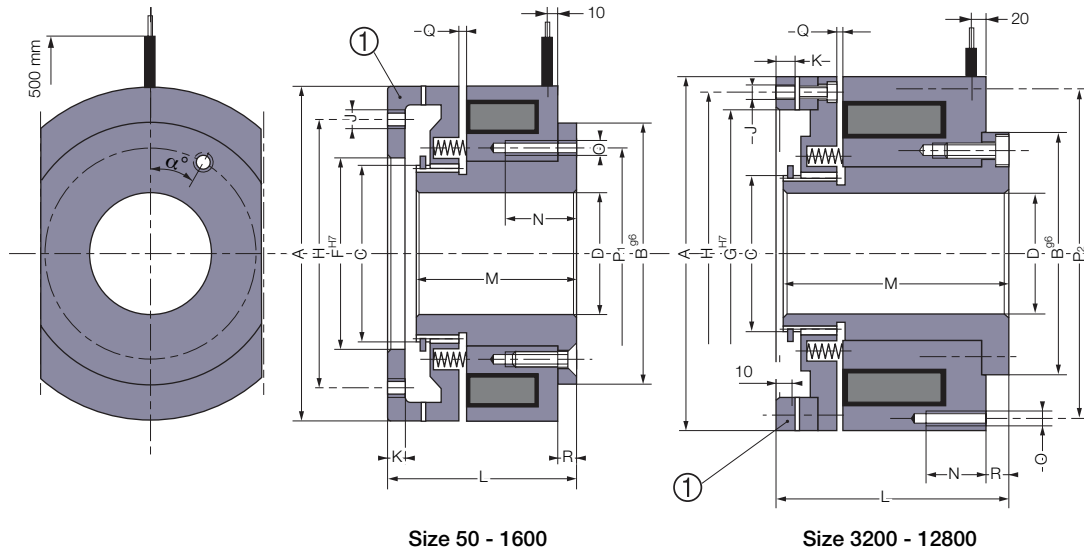

Sizes		50	100	200	400	800	1600	3200	6400	12800	
<b>Nom. Torque</b>	[Nm]	50	100	200	400	800	1600	3200	6400	12800	
<b>Max. Speed</b>	[min <sup>-1</sup> ]	5000	4300	3600	3300	2700	2100	1800	1500	1500	
<b>U Pull In / Holding</b>	[VDC]	103,5/48	103,5/48	103,5/48	103,5/48	103,5/48	103,5/48	207/103,5	207/103,5	207/103,5	
<b>Power Pull In</b>	P20 [W]	111	160,5	187	237	230	263	574	686	932	
<b>Power holding</b>	P20 [W]	21,1	30,6	35,5	45	43,3	50	143	172	233	
	A	90	105	115	140	185	225	265	320	385	
	B	70	80	85	110	150	155	170	204	245	
	C	45	55	60	75	100	108	125	145	175	
	D	32	40	44	57	77	82	97	112	132	
	F Min	40	45	50	65	105	110	-	-	-	
	F Max	58	70	80	95	130	155	-	-	-	
	G	-	-	-	-	-	-	215	260	315	
	H*	68	82	92	110	148	175	240	290	355	
	J*	4xM6	4xM6	6MX6	6xM8	6xM10	6xM12	12xM12	12xM14	12MX16	
	K	5	6	6	7	8	12	15	18	24	
	L	55	58	62	75	90	135	155	180	215	
	M	48	50	54	66	80	120	150	178	210	
	N	15	15	15	20	25	16	19	20	25	
	O	4xM5	4xM6	6xM6	6xM8	6xM10	8xM10	10xM12	12xM12	12xM16	
	P1	54	66	71	88	122	-	-	-	-	
	P2	-	-	-	-	-	210	245	290	355	
	Q	1	1,1	1,2	1,3	1,3	2	2,3	2,7	3,2	
	R	3,5	4,4	4,5	6	8	17	18	17,5	18	
	α	45°	45°	30°	30°	30°	22°30'	18°	15°	15°	
<b>Axial Load on Drive Cup</b>	① [daN]	30	45	65	115	180	330	900	1500	2200	
<b>Inertia</b>	① [kgm <sup>2</sup> ]	0,00034	0,00073	0,0010	0,0025	0,0095	0,022	0,0418	0,104	0,290	
<b>Weight</b>	[kg]	2	2,7	3,5	6,2	13	27	45	81	142	
<b>Connection</b>		<b>Leads</b>					<b>Cable</b>				

\*Drive cup ① is supplied undrilled. Fixing holes are shown for information only (on sizes 50 to 1600)

### Connector Options

(Delivered without cable)

2 poles, capacity : 0,5/2,5mm<sup>2</sup>

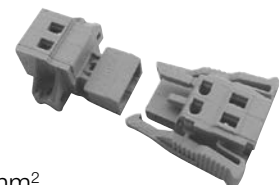

# P520 VAR 00

## Pneumatic Single Disc Brake

### Characteristics

- Pneumatically released
- Single disc
- Activated by spring pressure

### Utilisation

- Braking a shaft
- Holding a load

### Particularities

- For dry use
- No residual torque in disengaged position
- Fast response time

### Adjustments

- Airgap "T" should be adjusted at installation
- Requires wear compensation for dynamic applications

### Maintenance Manual

- SM 318

### Mounting Precautions

- Device intended for horizontal use. For vertical use, please consult the factory.

### Mounting Example

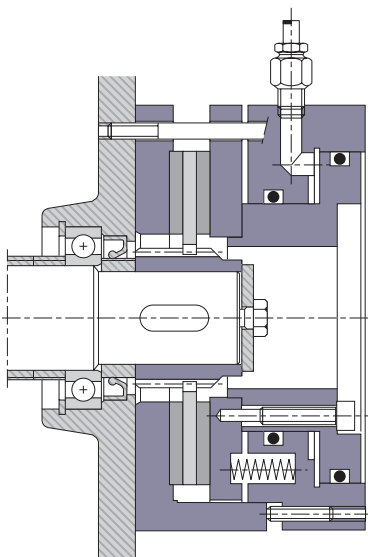

### Heat Dissipation

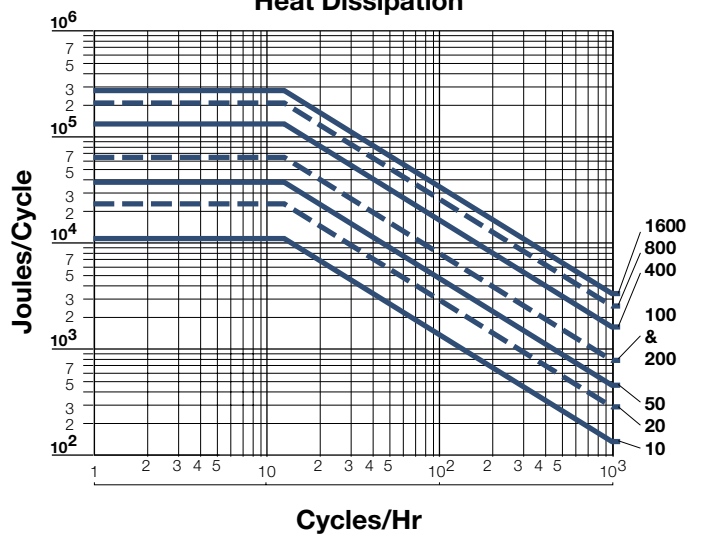

## Pneumatic Single Disc Brake

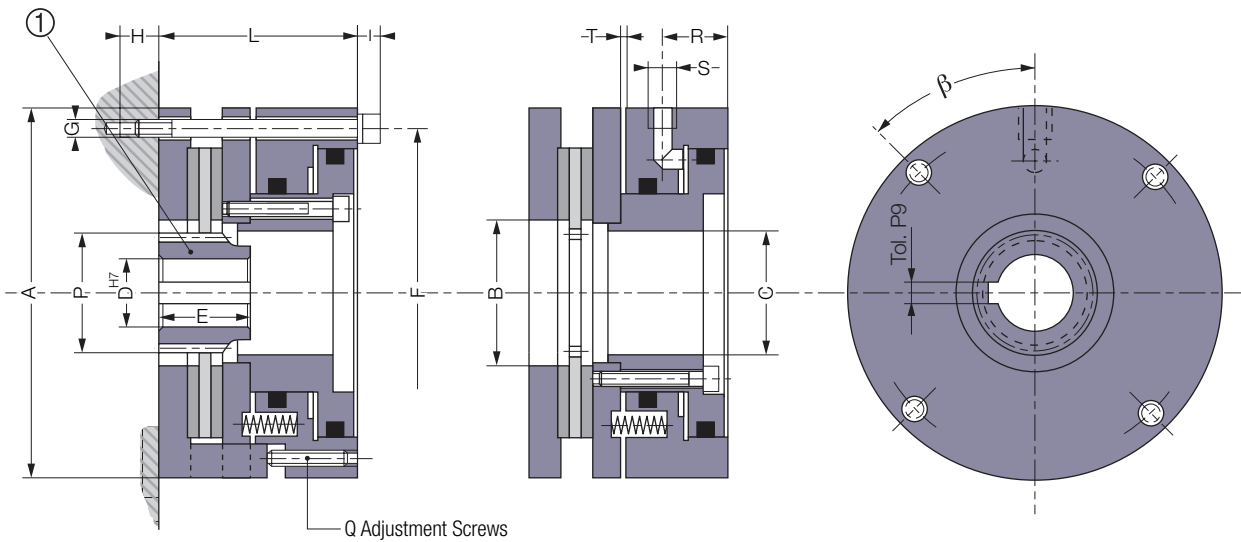

Sizes		10	20	50	100	200	400	800	1600
<b>Nom. Torque</b>	[Nm]	10	20	50	100	200	400	800	1600
<b>Max. Speed</b>	[min <sup>-1</sup> ]	6800	5000	4150	3200	2600	22000	1700	1500
<b>Operating Pressure</b>	[bar]	6	6	6	6	6	5	5	5
	A	90	120	150	190	220	265	320	395
	B	46	52	60	80	95	120	155	210
	C	32	40	54	70	82	98	124	168
	D min	10	14	18	22	28	30	35	50
	D max	22	25	35	40	55	65	80	110
	E	20	25	35	40	55	60	70	100
	F	80	105	130	165	200	240	294	360
	G	4xM6	4xM6	4xM8	4xM10	4xM10	4xM12	4xM12	4xM16
	H min	11	16	16	17	20	23	28	24
	I	8	8	10,5	13	13	15,5	15,5	20
	L	50	67	85	95	102	110	126	160
	Q	3xM6	4xM6	4xM8	4xM8	4xM10	4xM12	4xM16	4xM16
	R	18	24	29	28	35	37	42	50
	S	Rp 1/8"	Rp 1/8"	Rp 1/4"	Rp 1/4"	Rp 1/4"	Rp 3/8"	Rp 3/8"	Rp 3/8"
	β	45°	45°	45°	45°	80°	80°	80°	80°
<b>Airgap</b>	[T] min	0,2	0,2	0,3	0,3	0,3	0,4	0,4	0,5
<b>Pressure Angle</b>	[α]	20°	20°	20°	20°	20°	20°	20°	20°
<b>Number of Teeth</b>	[Z]	19	25	34	33	31	37	39	53
<b>Module</b>	[m]	1,667	1,5	1,5	2	2,5	2,5	3	3
<b>Pitch</b>	[Dp]	31,667	37,5	51	66	77,5	95,5	117	159
<b>Outside Diameter</b>	[P]	34,7	39	52,5	68	80	95	120	162
<b>Dimension on K teeth</b>		13,49	11,595	16,21	21,59	26,92	34,38	41,34	50,786
<b>K Teeth</b>	[K]	3	3	4	4	4	5	5	6
<b>Stroke Volume</b>	[cm <sup>3</sup> ]	8	13	19	31	59	91	143	266
<b>Inertia</b>	① [kgm <sup>2</sup> ]	0,0002	0,0003	0,0011	0,0033	0,0073	0,0165	0,0461	0,1255
<b>Weight</b>	[kg]	2,1	4,2	8,5	15,5	22,5	36	58	110
<b>Connection</b>		<b>Radiale</b>							

Keyways according to  
ISO/R 773 / BS 4235 / DIN 6885-1 / NF E 22-175, tolerance P9

# P620 VAR 00

## Pneumatic Multi Disc Brake

### Characteristics

- Pneumatically released
- Dual disc
- Activated by spring pressure

### Utilisation

- Braking a shaft
- Holding a load

### Particularities

- For dry use
- No residual torque in disengaged position
- Fast response time

### Adjustments

- Airgap "T" should be adjusted at installation
- Requires wear compensation for dynamic applications

### Maintenance Manual

- SM 318

### Mounting Precautions

- Device intended for horizontal use

Mounting Example

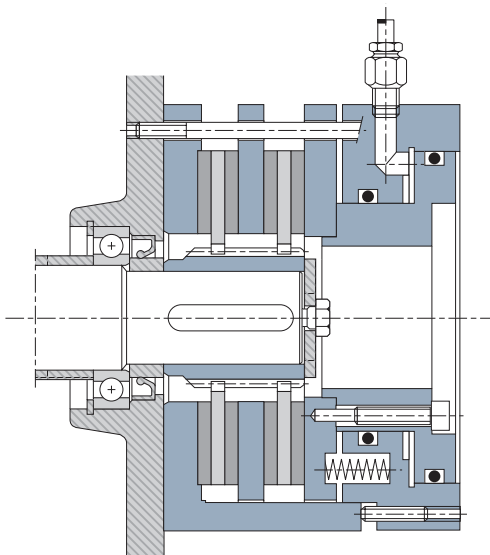

Heat Dissipation

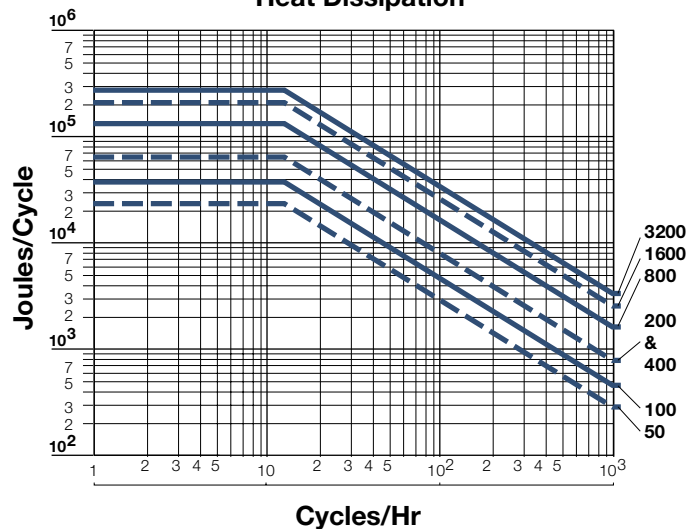



## Pneumatic Multi Disc Brake

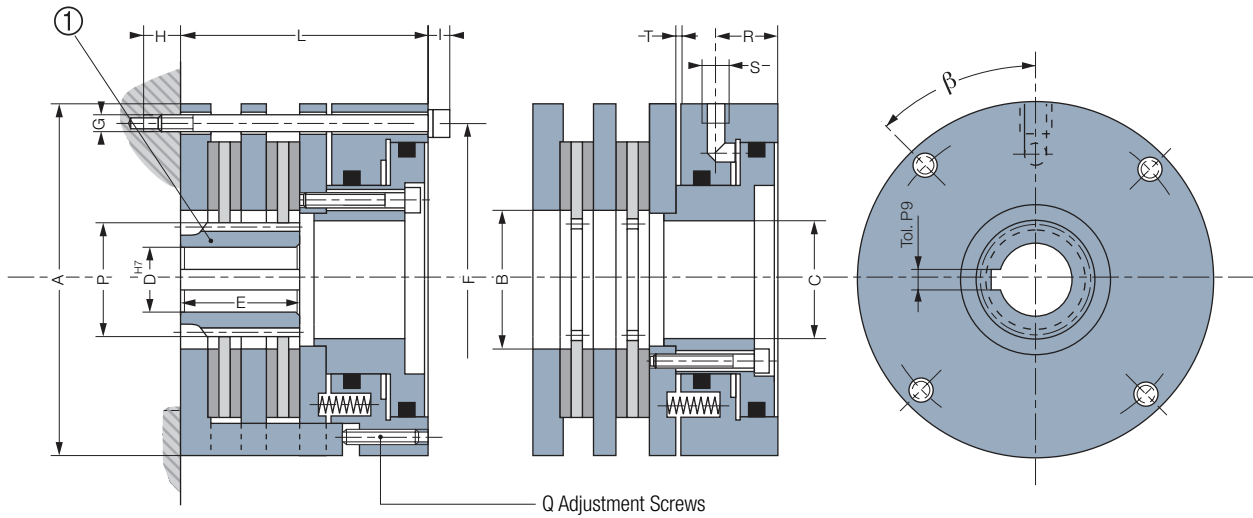

Sizes		50	100	200	400	800	1600	3200
<b>Nom. Torque</b>	[Nm]	50	100	200	400	800	1600	3200
<b>Max. Speed</b>	[min. <sup>-1</sup> ]	5000	4150	3200	2600	2200	1700	1500
<b>Operating Pressure</b>	[bar]	6	6	6	6	5	5	5
	A	120	150	190	220	265	320	395
	B	52	60	80	95	120	155	210
	C	40	54	70	82	98	124	168
	D min	14	18	22	28	30	35	50
	D max	25	35	40	55	65	80	110
	E	31	40	47	55	60	70	100
	F	105	130	165	200	240	294	360
	G	4xM6	4xM8	4xM10	4xM10	4xM12	4xM12	4xM16
	H min	13	21	29	24	33	33	35
	I	8	10,5	13	13	15,5	15,5	20
	L	80	103	117	124	136	158	198
	Q	4xM6	4xM8	4xM8	4xM10	4xM12	4xM16	4xM16
	R	24	29	28	35	37	42	50
	S	Rp 1/8"	Rp 1/4"	Rp 1/4"	Rp 1/4"	Rp 3/8"	Rp 3/8"	Rp 3/8"
	β	45°	45°	45°	80°	80°	80°	80°
<b>Airgap</b>	[T] min	0,3	0,4	0,4	0,4	0,5	0,5	0,6
<b>Pressure Angle</b>	[α]	20°	20°	20°	20°	20°	20°	20°
<b>Number of Teeth</b>	[Z]	25	34	33	31	37	39	53
<b>Module</b>	[m]	11,5	1,5	2	2,5	2,5	3	3
<b>Pitch</b>	[Dp]	37,5	51	66	77,5	92,5	117	159
<b>Outside Diameter</b>	[P]	39	52,5	68	80	95	120	162
<b>Dimension on K teeth</b>		11,595	16,21	21,59	26,92	34,38	41,34	50,786
<b>K Teeth</b>	[K]	3	4	4	4	5	5	5
<b>Stroke Volume</b>	[cm <sup>3</sup> ]	13	19	31	59	91	143	266
<b>Inertia</b>	① [kgm <sup>2</sup> ]	0,00053	0,0019	0,0060	0,0134	0,0296	0,0831	0,2313
<b>Weight</b>	[kg]	4,9	9,7	17,5	26	41	68	130
<b>Connection</b>		<b>Radial</b>						

Keyways according to  
ISO/R 773 / BS 4235 / DIN 6885-1 / NF E 22-175, tolerance P9

# FC-G - C410

## Centrifugal Brakes

### Characteristics

- Part (1) or core, mandatory driving, integral with two fly-weights (3) and return springs (4)
- Part (2), or drum connected to the driven part (clutch assembly) or to a fixed part (brake assembly)

### Particularities

- Without wear compensation adjustment
- Deferred action
- Dry application

### Utilisation

- The acceleration of the driving shaft and thus of the core (1) applies a stress to fly-weights (3). Up to a given speed shown on the table of characteristics, the return springs (4) compensate for the action of the centrifugal force. Beyond "nil torque" speed, the fly-weights (3) move apart from each other, then come into contact with drum (2). The transmitted torque is a function of the rotational speed.

### Adjustment

- No adjustment is required

### Maintenance Manual

- SM409

### Mounting Example

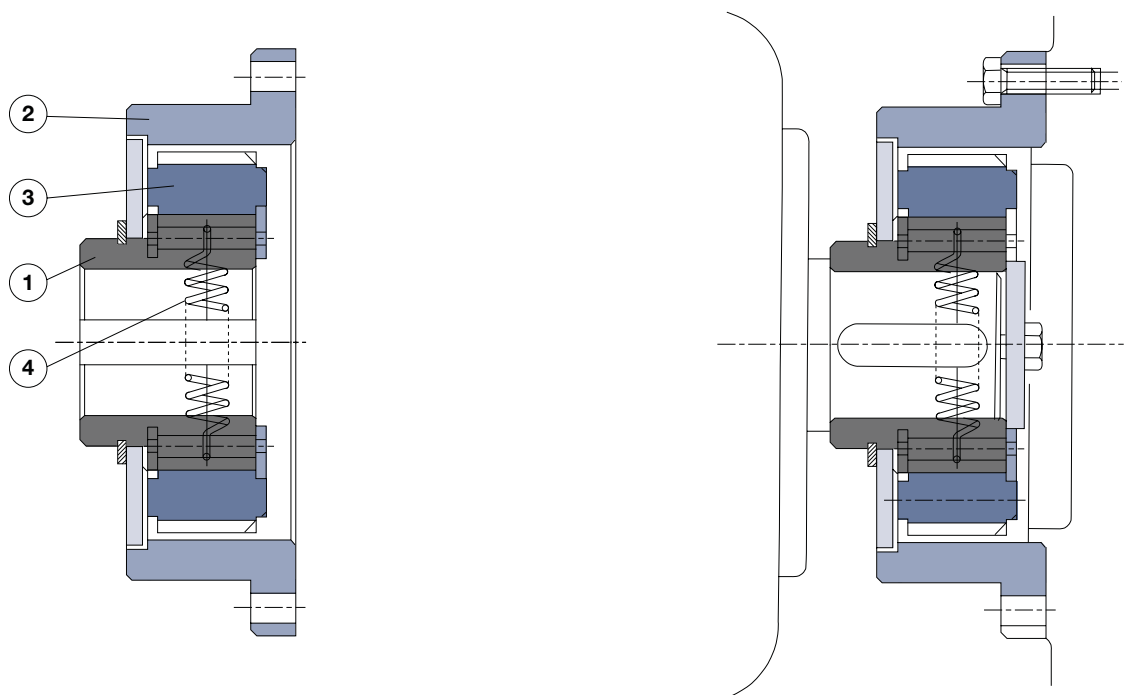

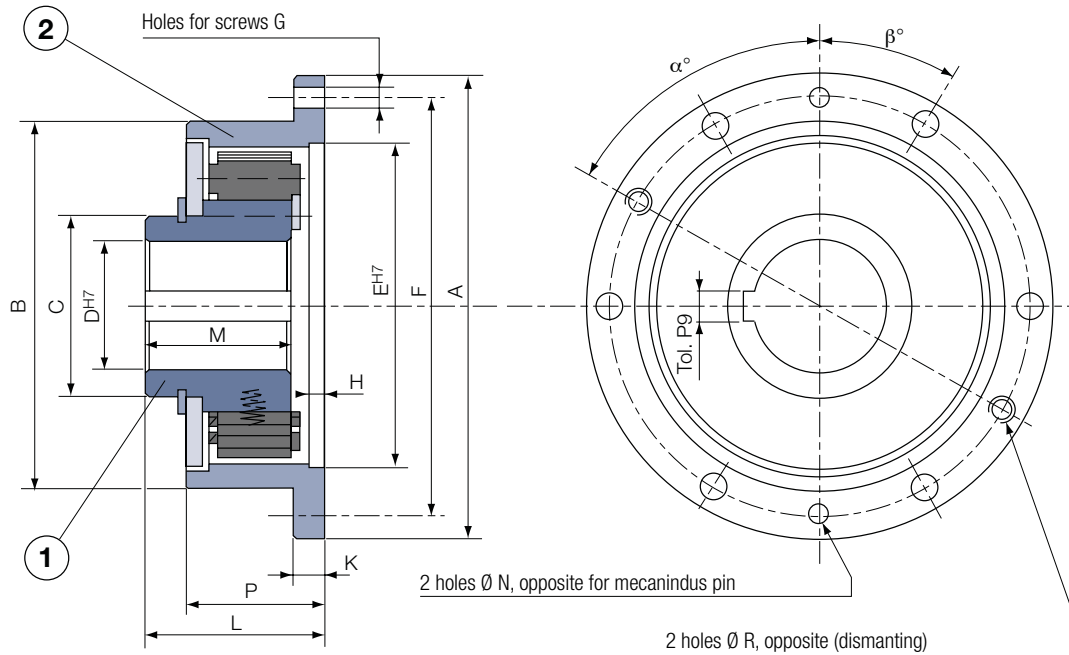

Speeds				
Nil torque	[RPM]	1300	1650	1850
Rated torque	[RPM]	2500	2700	2800

Sizes		5	10	20	40	80
Nom. Torque	[Nm]	50	100	200	400	800
Inertie ①	[kgm <sup>2</sup> ]	0,0054	0,0110	0,017	0,030	0,044
Inertie ②	[bar]	0,0393	0,0590	0,133	0,198	0,268
	A	220	220	280	280	280
	B	180	180	230	230	230
	C	80	80	110	110	110
	D min	16	16	20	20	20
	D max	55	55	70	70	70
	E	140	140	170	170	170
	F	200	200	255	255	255
	G	6xM8	6xM8	6xM12	6xM12	12xM12
	H	6	6	8	8	8
	K	15	15	20	20	20
	L	70	105	80	120	170
	M	57	92	64	104	150
	N	8	8	12	12	12
	P	55	97	63	110	161
	R	M8	M8	M10	M10	M10
	$\alpha^\circ$	120°	120°	120°	120°	90°
	$\beta^\circ$	30°	30°	30°	30°	15°
Weight	[kg]	8,5	15	18,5	30	43

Example of designation of a unit size 20, nil torque at 1650 RPM and rated torque at 2700 RPM :

FC 20 1650/2700 G

Keyways according to ISO/R 773 / BS 4235 / DIN 6885-1 / NF E 22-175, tolerance P9

# H420 VAR 00 VAR 01

## Hydraulic Multi Disc Brake

### Characteristics

- Hydraulically operated
- Multi disc
- Activated by spring pressure

### Utilisation

- Braking a shaft
- Holding a load

### Particularities

- Standard = VAR 00
- Hi-Tork = VAR 01
- For wet operation

### Adjustments

- No adjustment
- No wear adjustment required

### Maintenance Manual

- SM 320

### Mounting Precautions

- For horizontal use
- For vertical use, please consult the factory

### Mounting Example

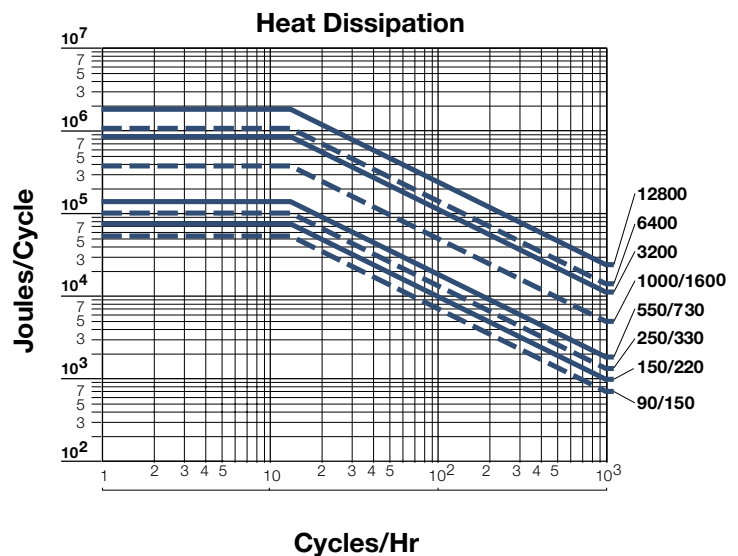
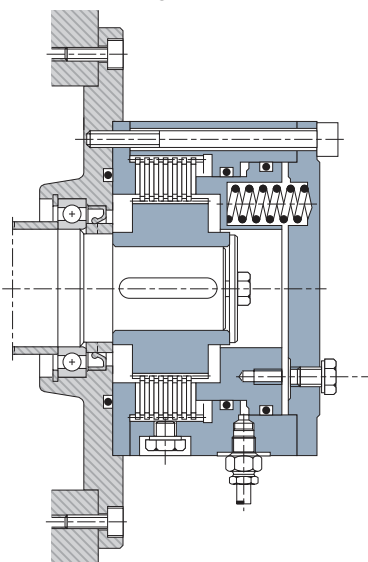

# H420 VAR 00 VAR 01

## Hydraulic Multi Disc Brake

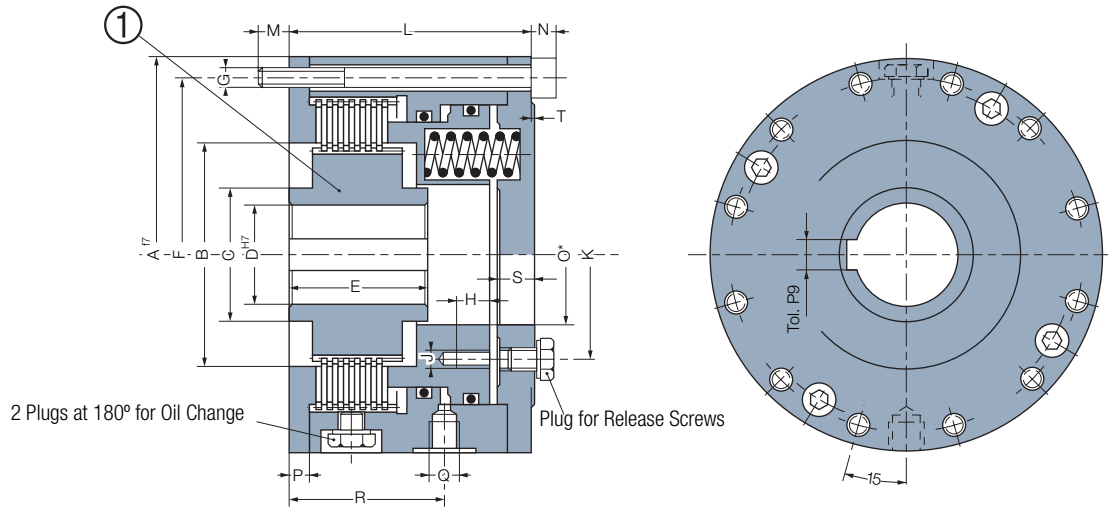

VAR 00	Sizes	Standard	90	150	250	550	1000	3200	6400	12800
	Wet	M dyn.	[Nm]	90	150	250	550	1000	3200	6400
	M stat.	[Nm]	150	240	400	850	1500	4800	9600	19000
	Open Pressure	[Nm]	29	24	21	23	22	22	35	35
VAR 01	Sizes	Hi-Tork	150	220	330	730	1600	-	-	-
	Wet	M dyn.	[Nm]	150	220	330	730	1600	-	-
	M stat.	[Nm]	240	350	520	1100	2400	-	-	-
	Open Pressure	[Nm]	48	36	28	31	36	-	-	-
	Max Speed	[min <sup>-1</sup> ]	5000	5000	4200	3500	2500	1700	1400	1100
	Admissible Pressure	[bar]	320	320	320	320	320	350	350	350
	A		127	142	160	195	252	375	445	545
	B		71	81	88	112	130	190	235	275
	C		43	56	70	100	116	153	185,5	225
	D min		15	15	25	30	40	60	75	100
	D max		32	35	45	60	90	125	140	170
	E		46	50	52	60	68	92	121	147
	F		114	128	144	176	232	348	413	507
	G		12xM8	12xM8	12xM8	12xM10	12xM12	12xM16	12xM20	12xM24
	H		10	10	15	15	15	20	26	32
	J		2xM6	3xM6	3xM6	3xM8	3xM8	3xM10	3xM16	6xM16
	K		70	84	86	118	144	210	212	260
	L		80	83	92	100	115	153	178	222
	M		10	17	18	20	25	27	32	38
	N		8	8	8	10	12	16	20	24
	O* max.		45	54	62	80	118	170	188	236
	P		7	7	8	9	11	15	20	22
	Q		Rp 1/8"	Rp 1/8"	Rp 1/4"	Rp 1/4"	Rp 1/4"	Rp 3/8"	Rp 1/2"	Rp 1/2"
	R		52	52	58	60,5	75,5	97	118	138
	S		12	12,5	13,5	15	17	-	-	-
	T		1	-	-	1,5	2	-	-	-
	Inertia	[kgm <sup>2</sup> ]	0,0008	0,0014	0,0021	0,0060	0,0236	0,1105	0,37	0,94
	Weight	[kg]	6	8,2	12	20	37,5	119	196	360
	Stroke Volume (new)	[cm <sup>3</sup> ]	3,8	4,9	8,2	12	18,5	74	121	210
	Stroke Volume (max)	[cm <sup>3</sup> ]	6,5	9	16	24	36,5	121	205	370
	Connection		Radial							

Keyways according to ISO/R 773 / BS 4235 / DIN 6885-1 / NF E 22-175, tolerance P9  
 \*The closing flange is delivered prebored (dimension O). For shaft passing throughout the brake, please consult us.

# Power Supply

## Controls

### CBC 400/450

- Standard power supply with one or two outputs
- CBC 450 model includes multi tap input transformer

### Maintenance Manual

- SM 322

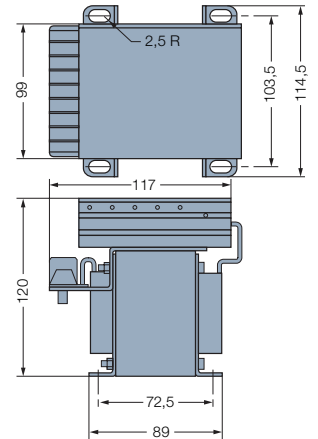
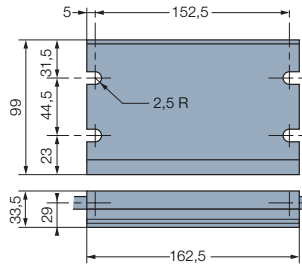

Model		CBC 400-24	CBC 400-90	CBC 450-90
	Part #	K6006-448-002	K6006-448-003	K6006-448-006
<b>Supply</b>	VAC	24 - 30	120	120/220/240/380/480
	Hz	50/60	50/60	50/60
	VA	250	250	250
<b>Output 1 &amp; 2</b>	VDC	24	90	90
	A min	5	1	1
	A max	5	2	1.2
<b>Input Signals</b>	VCD	10 - 30	10 - 30	10 - 30
	mA	3 - 9	3 - 9	3 - 9
	Logic 1	pos / neg	pos / neg	pos / neg
<b>Noise Suppression Range</b>	Hz	40 - 600	40 - 600	40 - 600
<b>Sensor Supply</b>	VCD	12	12	12
	mA	100	100	250
<b>Protection Fuse</b>	A	6.3	2.5	1.5
<b>Ambient Temperature</b>	°C	0 - 50	0 - 50	0 - 50
<b>IP65 Enclosed</b>	°C	-10 - +45	-10 - +45	-10 - +45
<b>Storage Temperature</b>	°C	-25 - +80	-25 - +80	-25 - +80

### CBC 500/550

- Power supply with torque adjustment capability with one or two adjustable outputs
- CBC 550 model includes multi tap input transformer

### Maintenance Manual : SM 323

- SM 323

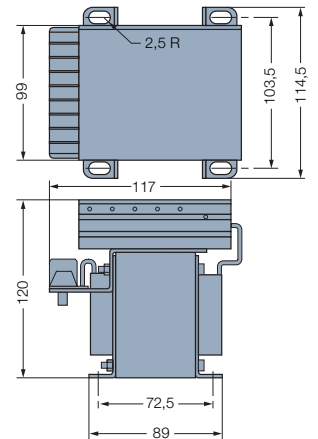
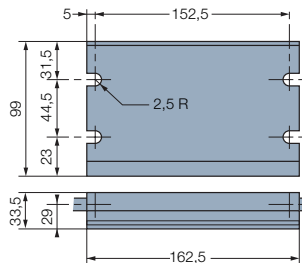

Model		CBC 500-24	CBC 500-90	CBC 550-24	CBC 550-90
	Part #	K6006-448-002	K6006-448-003	K6006-448-005	K6006-448-006
<b>Supply</b>	VAC	24 - 30	120	120/220/240/380/480	50/60
	Hz	50/60	50/60	50/60	50/60
	VA	250	250	250	250
<b>Output 1 &amp; 2</b>	VDC	24	90	24	90
	A min	5	1	4	1
	A max	5	2	4	1.2
<b>Input Signals</b>	VCD	10 - 30	10 - 30	10 - 30	10 - 30
	mA	3 - 9	3 - 9	3 - 9	3 - 9
	Logic 1	pos / neg	pos / neg	pos / neg	pos / neg
<b>Noise Suppression Range</b>	Hz	40 - 600	40 - 600	40 - 600	40 - 600
<b>Sensor Supply</b>	VCD	12	12	12	12
	mA	100	100	250	250
<b>Protection Fuse</b>	A	6.3	2.5	5	1.5
<b>Ambient Temperature</b>	°C	0 - 50	0 - 50	0 - 50	0 - 50
<b>IP65 Enclosed</b>	°C	-10 - +45	-10 - +45	-10 - +45	-10 - +45
<b>Storage Temperature</b>	°C	-25 - +80	-25 - +80	-25 - +80	-25 - +80

### CBC 700

- Power supply with overexcitation control with one or two outputs

#### Option:

- IP65 enclosed, Part# K6042-101-004

#### MAINTENANCE MANUAL : SM 324

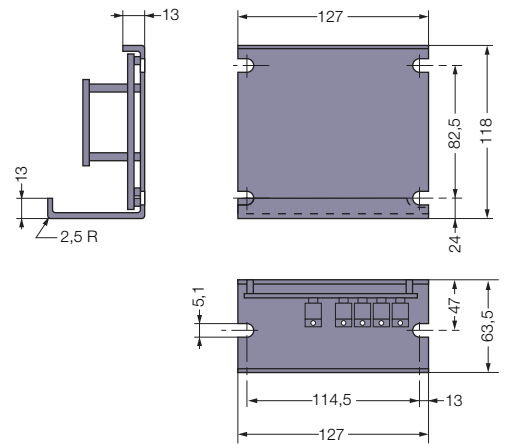

Model		CBC 700-24	CBC 700-90
	Part #	K6006-448-002	K6006-448-003
<b>Supply</b>	VAC	24 – 30	120
	Hz	50/60	50/60
	VA	150	100
<b>Output 1 &amp; 2</b>	VDC	24	90
	VDC exc	105	340
	A min	3.5	0,5
	A max	3.5	0,5
<b>Input Signals</b>	VCD	10 – 30	10 – 30
	mA	10 – 35	10 – 35
	Logic 1	pos / neg	pos / neg
<b>Noise Suppression Range</b>	Hz	40 – 600	40 – 600
<b>Sensor Supply</b>	VCD	12	12
	mA	250	250
<b>Protection Fuse</b>	A	5	2
<b>Ambient Temperature</b>	°C	-18 - +60	-18 - +60
<b>IP65 Enclosed</b>	°C	-18 - +45	-18 - +45
<b>Storage Temperature</b>	°C	-25 - +80	-25 - +80

# Power Supply

## Controls

### CBC 140-T

- Transformer

#### Maintenance Manual

- SM 326

	Part#	B905-9999
<b>Supply</b>	VAC	230/400
	Hz	50/60
	VA	150
<b>Output</b>	VAC	27 / 30
	A	6

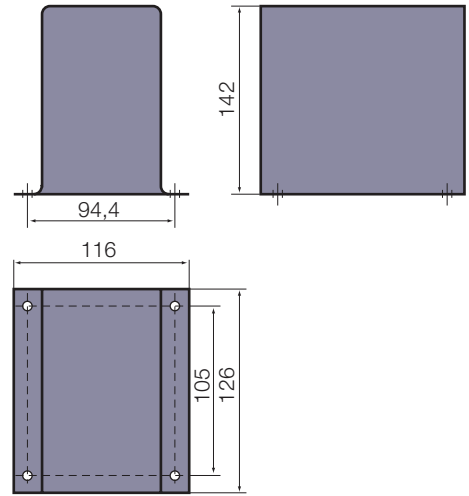

### CBC 140-1

- Half wave power supply

#### Maintenance Manual

- SM 326

	Part#	ACG830A1P1
<b>Supply</b>	VAC	230/400
	Hz	50/60
<b>Output</b>	VDC	103,5/180
	A	1

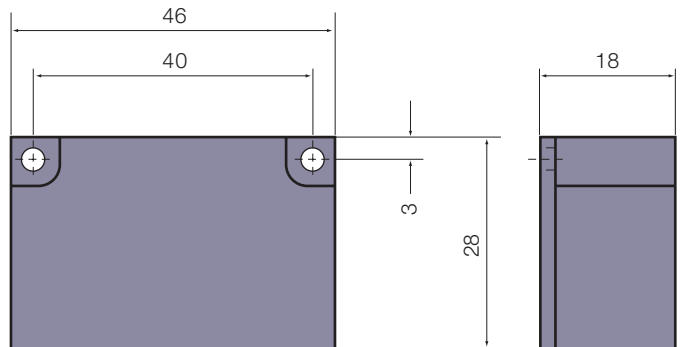

### CBC 140-2

- Full wave power supply

#### Maintenance Manual

- SM 326

	Part#	ACG830A1P2		
<b>Supply</b>	VAC	27	115	230
	Hz		50/60	
<b>Output</b>	VDC	24	103,5	207
	A		2	

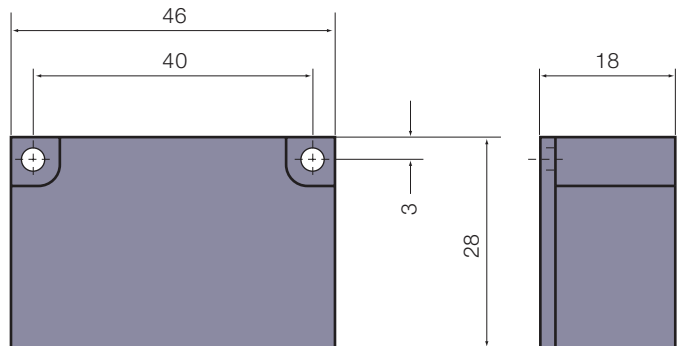



### CBC 140-5

- Single or dual wave power supply
- For DIN rail mounting EN 50022
- With over-excitation control
- **Suitable for use with clutches and brakes with a 4,5 A (24V/108W), 4 A (103,5 V/414W and 2 A (207 V/414W) nominal current rating**
- **Admissible power during an overexcitation of 2 s max. at 207 V : 931 W (4,5 A)**
- Holding voltage set 50% max of the unit voltage

### Maintenance Manual

- SM 326

Part# BT767000416							
<b>Supply</b>	VAC 50/60 Hz	230		115		30	
<b>Overexcitation</b>	VDC	207	103,5	103,5	51,7	24	12
<b>Holding voltage</b>	VDC	$U_i/2$		$U_i/2$		$U_i/2$	
<b>Holding current</b>	A	2	4	4	4	4,5	4,5
<b>Holding power</b>	W	414	414	414	207	108	54

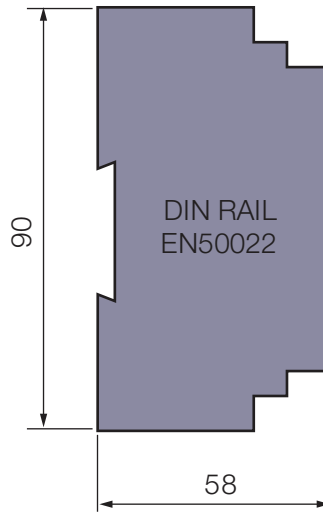
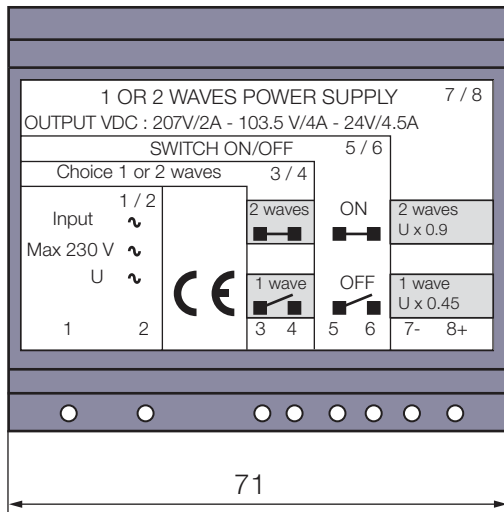

### Connector BT212095406

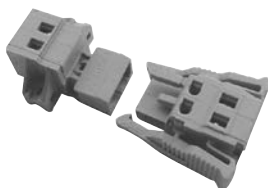

# Your Requirements

## Technical Data

Customer \_\_\_\_\_  
Name \_\_\_\_\_  
Dept \_\_\_\_\_  
Address \_\_\_\_\_  
Tel \_\_\_\_\_ Fax \_\_\_\_\_

Application \_\_\_\_\_  
Machine Type \_\_\_\_\_  
Main Function \_\_\_\_\_

### Principle

Clutch  Brake  Torque Limiter

### Energy

Hydr.  Pneum. \_\_\_\_\_ Bar  $\pm$  20%

 \_\_\_\_\_ N

AC  DC  BAT

Nom. Voltage \_\_\_\_\_  $\pm$  %

### Design Base

Tooth  Single Disc  Multidisques

### Engagement Mode

Power Activated  Powerless Activated

Rotating  At Static

### Mounting

     \_\_\_\_\_°

Residual Torque Allowed in Function OFF  Yes  No

### Input Transmission

Direct  Pulley

### Output Transmission

Direct  Pulley

### Environment

Dry  Oil  Mixed

Vibration min./max. \_\_\_\_\_/\_\_\_\_\_ Hz

Shock min./max. \_\_\_\_\_/\_\_\_\_\_ Hz

Temperature min./max. \_\_\_\_\_/\_\_\_\_\_ Hz

Humidity min./max. \_\_\_\_\_/\_\_\_\_\_ Hz

### Protection Class

Without  IP

### Torque to Transmit

Torque of Motor \_\_\_\_\_ Nm

P \_\_\_\_\_ kW Speed \_\_\_\_\_ min<sup>-1</sup>

Load Torque (See p. 9) \_\_\_\_\_ Nm

Torque from Inertia (See p. 9-10) \_\_\_\_\_ Nm

Inertia in Rotation (See p. 9-10) \_\_\_\_\_ kgm<sup>2</sup>

Inertia in Translation (See p. 9-10) \_\_\_\_\_ kgm<sup>2</sup>

Slip Torque (Torque Limiter)

Max. \_\_\_\_\_ Nm Min. \_\_\_\_\_ Nm

### Input Speed

Max. \_\_\_\_\_ min<sup>-1</sup> Min. \_\_\_\_\_ min<sup>-1</sup>

### Engage Speed

Max. \_\_\_\_\_ min<sup>-1</sup> Min. \_\_\_\_\_ min<sup>-1</sup>

### Disengage Speed

Max. \_\_\_\_\_ min<sup>-1</sup> Min. \_\_\_\_\_ min<sup>-1</sup>

### Response Time

Braking Time or Angle T= \_\_\_\_\_ s

°= \_\_\_\_\_ s

Indifferent

Coupling Time or Angle T= \_\_\_\_\_ s

°= \_\_\_\_\_ s

Indifferent

Disengage/No Brake Time T= \_\_\_\_\_ s

°= \_\_\_\_\_ s

Indifferent

### Duty Cycle

Permanent  Exceptional

Cycled Number of Cycle/Hour \_\_\_\_\_ cy/h

### Life Time

Expected Life Time \_\_\_\_\_ H

### Duty Cycle

Protection against Corrosion



## Warner Electric Facilities

### North America

#### USA

31 Industrial Park Road  
New Hartford, CT 06057 - USA  
860-379-1252

*Electromagnetic Clutches  
and Brakes*

449 Gardner Street  
South Beloit, IL 61080 - USA  
815-389-3771

4578 East Park 30 Drive  
Columbia City, IN 46725 - USA  
260-244-6183

*Precision Electric Coils and  
Electromagnetic Clutches and  
Brakes*

**Customer Service**  
1-800-825-6544

**Application Support**  
1-800-825-9050

### Europe

#### France

7, rue Champfleury, B.P. 20095  
St Barthelemy d'Anjou - France  
+33 (0)2 41 21 24 24

*Electromagnetic Clutches  
and Brakes*

**Customer Service**  
+33 (0)2 41 21 24 76

**Application Support**  
+33 (0) 2 41 21 24 24

### Asia Pacific

#### Australia

+61 2 9894 0133

#### China

+86 21 5169-9255

#### Hong Kong

+852 2615 9313

#### Singapore

+65 6487 4464

#### Taiwan

+886 2 2577 8156

#### Thailand

+66 2322 5527

## The Brands of Altra Motion

### Couplings

**Ameridrives**  
[www.ameridrives.com](http://www.ameridrives.com)

**Bibby Turboflex**  
[www.bibbyturboflex.com](http://www.bibbyturboflex.com)

**Guardian Couplings**  
[www.guardiancouplings.com](http://www.guardiancouplings.com)

**Huco**  
[www.huco.com](http://www.huco.com)

**Lamiflex Couplings**  
[www.lamiflexcouplings.com](http://www.lamiflexcouplings.com)

**Stromag**  
[www.stromag.com](http://www.stromag.com)

**TB Wood's**  
[www.tbwoods.com](http://www.tbwoods.com)

### Linear Systems

**Thomson**  
[www.thomsonlinear.com](http://www.thomsonlinear.com)

**Warner Linear**  
[www.warnerlinear.com](http://www.warnerlinear.com)

### Geared Cam Limit Switches

**Stromag**  
[www.stromag.com](http://www.stromag.com)

### Engineered Bearing Assemblies

**Kilian**  
[www.kilianbearings.com](http://www.kilianbearings.com)

### Electric Clutches & Brakes

**Matrix**  
[www.matrix-international.com](http://www.matrix-international.com)

**Stromag**  
[www.stromag.com](http://www.stromag.com)

**Warner Electric**  
[www.warnerelectric.com](http://www.warnerelectric.com)

**Deltran**  
[www.thomsonlinear.com](http://www.thomsonlinear.com)

### Belted Drives

**TB Wood's**  
[www.tbwoods.com](http://www.tbwoods.com)

### Heavy Duty Clutches & Brakes

**Twiflex**  
[www.twiflex.com](http://www.twiflex.com)

**Stromag**  
[www.stromag.com](http://www.stromag.com)

**Svendborg Brakes**  
[www.svendborg-brakes.com](http://www.svendborg-brakes.com)

**Wichita Clutch**  
[www.wichitaclutch.com](http://www.wichitaclutch.com)

### Gearing & Specialty Components

**Bauer Gear Motor**  
[www.bauergears.com](http://www.bauergears.com)

**Boston Gear**  
[www.bostongear.com](http://www.bostongear.com)

**Delevan**  
[www.delevan.com](http://www.delevan.com)

**Delroyd Worm Gear**  
[www.delroyd.com](http://www.delroyd.com)

**Nuttall Gear**  
[www.nuttallgear.com](http://www.nuttallgear.com)

### Engine Braking Systems

**Jacobs Vehicle Systems**  
[www.jacobsvehiclesystems.com](http://www.jacobsvehiclesystems.com)

### Precision Motors & Automation

**Kollmorgen**  
[www.kollmorgen.com](http://www.kollmorgen.com)

### Miniature Motors

**Portescap**  
[www.portescap.com](http://www.portescap.com)

### Overrunning Clutches

**Formsprag Clutch**  
[www.formsprag.com](http://www.formsprag.com)

**Marland Clutch**  
[www.marland.com](http://www.marland.com)

**Stieber**  
[www.stieberclutch.com](http://www.stieberclutch.com)

Neither the accuracy nor completeness of the information contained in this publication is guaranteed by the company and may be subject to change in its sole discretion. The operating and performance characteristics of these products may vary depending on the application, installation, operating conditions and environmental factors. The company's terms and conditions of sale can be viewed at <http://www.altramotion.com/terms-and-conditions/sales-terms-and-conditions>. These terms and conditions apply to any person who may buy, acquire or use a product referred to herein, including any person who buys from a licensed distributor of these branded products.

©2019 by Warner Electric LLC. All rights reserved. All trademarks in this publication are the sole and exclusive property of Warner Electric LLC or one of its affiliated companies.